

TM-S9000MJ

Technical Reference Guide

Product Overview

Describes features and general specifications for the product.

Setup

Describes setup and installation of the product.

Application Development Information

Describes how to control the scanner and necessary information when you develop applications.

Handling

Describes how to handle the product.

Appendix

Describes the interface and character code tables.

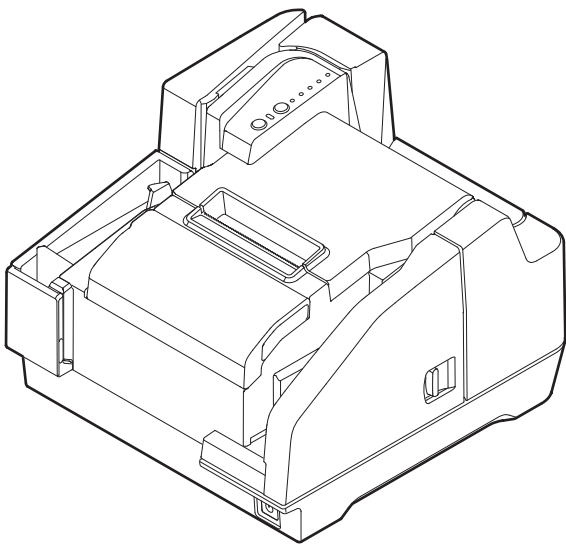

Cautions

- No part of this document may be reproduced, stored in a retrieval system, or transmitted in any form or by any means, electronic, mechanical, photocopying, recording, or otherwise, without the prior written permission of Seiko Epson Corporation.
- The contents of this document are subject to change without notice. Please contact us for the latest information.
- While every precaution has been taken in the preparation of this document, Seiko Epson Corporation assumes no responsibility for errors or omissions.
- Neither is any liability assumed for damages resulting from the use of the information contained herein.
- Neither Seiko Epson Corporation nor its affiliates shall be liable to the purchaser of this product or third parties for damages, losses, costs, or expenses incurred by the purchaser or third parties as a result of: accident, misuse, or abuse of this product or unauthorized modifications, repairs, or alterations to this product, or (excluding the U.S.) failure to strictly comply with Seiko Epson Corporation's operating and maintenance instructions.
- Seiko Epson Corporation shall not be liable against any damages or problems arising from the use of any options or any consumable products other than those designated as Original Epson Products or Epson Approved Products by Seiko Epson Corporation.

Trademarks

EPSON is a registered trademark of Seiko Epson Corporation.



Exceed Your Vision is a registered trademark or trademark of Seiko Epson Corporation.

©Seiko Epson Corporation 2012-2017. All rights reserved.

For Safety

Key to Symbols

The symbols in this manual are identified by their level of importance, as defined below. Read the following carefully before handling the product.

 WARNING	You must follow warnings carefully to avoid serious bodily injury.
 CAUTION	Provides information that must be observed to prevent damage to the equipment or loss of data. <ul style="list-style-type: none">• Possibility of sustaining physical injuries.• Possibility of causing physical damage.• Possibility of causing information loss.
CAUTION	Provides information that must be observed to avoid damage to your equipment or a malfunction.
NOTE	Provides important information and useful tips.

Warnings



WARNING

- **To avoid risk of electric shock, do not set up this product or handle cables during a thunderstorm.**
- **Never insert or disconnect the power plug with wet hands.**
Doing so may result in severe shock.
- **Handle the power cable with care.**
Improper handling may lead to fire or electric shock.
 - * Do not modify or attempt to repair the cable.
 - * Do not place any heavy object on top of the cable.
 - * Avoid excessive bending, twisting, and pulling.
 - * Do not place the cable near heating equipment.
 - * Check that the plug is clean before plugging it in.
 - * Be sure to push the plug all the way in.
- **Be sure to use the specified AC adapter.**
Connection to an improper power source may cause fire or shock.
- **Do not place multiple loads on the power outlet.**
Overloading the outlet may lead to fire.
- **Shut down your equipment immediately if it produces smoke, a strange odor, or unusual noise.**
Continued use may lead to fire. Immediately unplug the equipment and contact your dealer or a Seiko Epson service center for advice.
- **Never attempt to repair this product yourself.**
Improper repair work can be dangerous.
- **Never disassemble or modify this product.**
Tampering with this product may result in injury or fire.
- **Do not allow foreign matter to fall into the equipment.**
Penetration by foreign objects may lead to fire.
- **If water or other liquid spills into this equipment, do not continue to use it.**
Continued use may lead to fire. Unplug the power cord immediately and contact your dealer or Epson service center for advice.
- **Do not use aerosol sprayers containing flammable gas inside or around this product.**
Doing so may cause fire.

Cautions



- **Do not connect cables in ways other than those mentioned in this manual.**
Different connections may cause equipment damage or fire.
- **Be sure to set this equipment on a firm, stable, horizontal surface.**
The product may break or cause injury if it falls.
- **Do not use this product in locations subject to high humidity or dust levels.**
Excessive humidity and dust may cause equipment damage or fire.
- **Do not place heavy objects on top of this product. Never stand or lean on this product.**
Equipment may fall or collapse, causing breakage and possible injury.
- **Take care not to injure your fingers on the manual cutter**
 - * When you remove printed paper
 - * When you perform other operations, such as loading/replacing roll paper
- **Before leaving the product unused for an extended period, make sure the ink cartridge is installed, turn the product off using the power button, and unplug the product to ensure safety.**
- **Do not connect a telephone line to the drawer kick-out connector; otherwise the product and the telephone line may be damaged.**

Restriction of Use

When this product is used for applications requiring high reliability/safety such as transportation devices related to aviation, rail, marine, automotive, etc.; disaster prevention devices; various safety devices etc; or functional/precision devices, etc., you should use this product only after giving consideration to including fail-safes and redundancies into your design to maintain safety and total system reliability. Because this product was not intended for use in applications requiring extremely high reliability/safety such as aerospace equipment, main communication equipment, nuclear power control equipment, or medical equipment related to direct medical care, etc., please make your own judgment on this product's suitability after a full evaluation.

About this Manual

Aim of the Manual

This manual was created to provide information on development and design of scanner applications for developers.

Manual Content

The manual is made up of the following sections:

Chapter 1	Product Overview
Chapter 2	Setup
Chapter 3	Application Development Information
Chapter 4	Handling
Appendix	Specifications of USB Interface Character Code Tables

Contents

■ For Safety	3
Key to Symbols	3
Warnings	4
Cautions	5
■ Restriction of Use	5
■ About this Manual	6
Aim of the Manual	6
Manual Content	6
■ Contents	7

Product Overview **11**

■ Features	11
■ Product Configuration	12
Color	12
Attachments	12
■ Part Names and Functions	13
Power Button	14
Control Panel	14
Connectors	16
■ Offline	17
■ Processing Modes for Cut Sheet Paper	18
High-Speed Mode	18
Confirmation Mode	20
■ Selectable Functions for Processing Cut Sheet	24
■ Error Status	26
Automatically Recoverable Errors	26
Recoverable Errors	27
Unrecoverable Errors	28
■ NV Memory (Non-Volatile Memory)	29
NV Graphics Memory	29
User NV Memory	29
Memory Switches	29
R/E (Receipt Enhancement)	30
User-defined Page	30
Maintenance Counter	30
■ Maintenance Counter	31
■ Product Specifications	32
Printing Specifications	34

Character Specifications	36
Scanner Specifications	37
MSR (Factory Option).....	38
Paper Specifications	39
Printable Area	41
Printing and Cutting Positions for Roll Paper	42
Scannable Area	43
MICR Readable Area	45
Area for Electric Endorsement	45
Environmental Conditions	46
Reliability.....	47
External Dimensions and Mass.....	48

Setup 50

■ Flow of Setup	50
■ Installing the Product	51
Important Notes on Installation	51
■ Connecting the Product to the Host Computer	52
■ Connecting the Power Supply Unit.....	53
■ Installing and Replacing the Ink Cartridge	54
■ Installing and Replacing the Roll Paper.....	56
■ Connecting the Cash Drawer	57
Connecting the Drawer Kick-out Cable	57
■ Setting the Memory Switches and R/E	59
Functions	60

Application Development Information..... 64

■ Software	64
Operating Environment	64
Software for Windows	65
Software for Linux	66
How to Get Drivers, Utilities, and Manuals.....	66
■ Setting/Checking Modes	67
Self-test Mode	67
NV Graphics Print Mode	69
Receipt Enhancement Information Print Mode	71
Memory Switch Setting Mode.....	72

Handling 73

■ Turning On/Off the Product..... 73

Turning On	73
Turning Off	73

■ Opening Covers 74

Opening the Roll Paper Cover.....	74
Opening the Ink Cartridge Cover.....	74
Opening the MICR Cover.....	75
Opening the Rear Cover	75
Opening the Scanner Cover.....	76

■ Processing Cut Sheet Paper 77

Flow of Single Pass Processing.....	77
Important Notes on Processing Cut Sheet Paper	77
Inserting Cut Sheet Paper	78
Ejecting Cut Sheet Paper	79

■ Scanning ID Cards..... 80

■ Reading Magnetic Stripe Cards..... 81

■ Cleaning..... 82

Cleaning the Thermal Head.....	82
Cleaning the Ink-Jet Head	82
Cleaning the MICR Head	83
Cleaning the Scanner.....	83
Cleaning the Product Case	84

■ Troubleshooting 86

Error LED Is On or Flashing	86
Paper or ID Card Is Jammed.....	86
Printout Is Faint	87
Reading/Scanning Is not Normal.....	87
Roll Paper Cover Will not Open	88

■ Preparing for Transport 89

Install the transportation cartridge	89
Pack the scanner.....	89

Appendix..... 90

■ Specifications of USB Interface 90

USB Interface (Type B).....	90
Optional USB Interface (Type A).....	90

■ Character Code Tables 91

Common to All Pages.....	92
Page 0 (PC437: USA, Standard Europe).....	93
Page 1 (Katakana).....	94

Page 2 (PC850: Multilingual)	95
Page 3 (PC860: Portuguese)	96
Page 4 (PC863: Canadian-French).....	97
Page 5 (PC865: Nordic)	98
Page 16 (WPC1252)	99
Page 17 (PC866: Cyrillic #2)	100
Page 18 (PC852: Latin2)	101
Page 19 (PC858: Euro)	102
Page 255 (User-Defined Page)	103
International Character Sets	104

Product Overview

This chapter describes features and specifications of the TM-S9000MJ.

Features

This compact, full-scale, up-grade hybrid product integrates functions of printing, check computerization, personal ID image reading, and magnetic card stripe reading (optional) required mainly for reception work at banks.

The main features are as follows.

- Small-footprint
- Roll paper printing function
 - Autocutter as standard equipment
 - Paper-saving function
- Check endorsement, cut sheet paper (cut sheet receipts, cashier's check) printing
 - Ink-jet printing of multiple line and high resolution with 360 nozzle and 180 dpi
- Check magnetic ink character reader (E13B, CMC7) (supported by the driver.)
 - Capturing image on the face and back of cut sheet paper and personal ID (such as driver's license)
- Capability in obtaining binary (only cut sheet paper is supported.), grayscale, color, and infrared light source images
- Auto sheet feeder
- Double feed detection for cut sheet paper
- Function to judge improper insertion of checks
- IQA (Image Quality Assurance) (Supported by the driver)
- OCR (Optional Character Recognition) (OCR-A font, OCR-B font, barcodes) (Supported by the driver)
- High-speed USB (USB 2.0 compliant) port
- Maintenance counter that is convenient for remote maintenance
- Buzzer
- Connection to a cash drawer
- Low ink detection, notifications to request replacing the ink cartridge
- Paper separation using two exit pockets (supported by the two-pocket models only.)
- Magnetic stripe reader (factory option)
- USB-HUB (factory option)

Product Configuration

The TM-S9000MJ differs in function and equipment depending on the combinations of the following specifications.

- Document processing speed: 110 dpm or 200 dpm
- Number of document exit pockets: 1 pocket or 2 pockets
- Whether or not the product has an MSR (Magnetic Stripe Reader) and USB (Type A) connectors

Processing speed	Number of document pockets	MSR	USB (Type A) connectors
110 dpm	1 pocket	Installed	Installed
		Not installed	Not installed
	2 pockets	Installed	Installed
		Not installed	Not installed
200 dpm	1 pocket	Installed	Installed
		Not installed	Not installed
	2 pockets	Installed	Installed
		Not installed	Not installed

dpm: documents per minute

Color

EDG (Epson Dark Gray)

Attachments

- Thermal roll paper (for operation check)
- USB cable
- 2 dedicated ink cartridges (Model: SJIC18(K))
- AC cable*
- AC adapter
- Setup Guide
- User's Manual

* May not be included depending on the product model.

Part Names and Functions

Two-pocket model

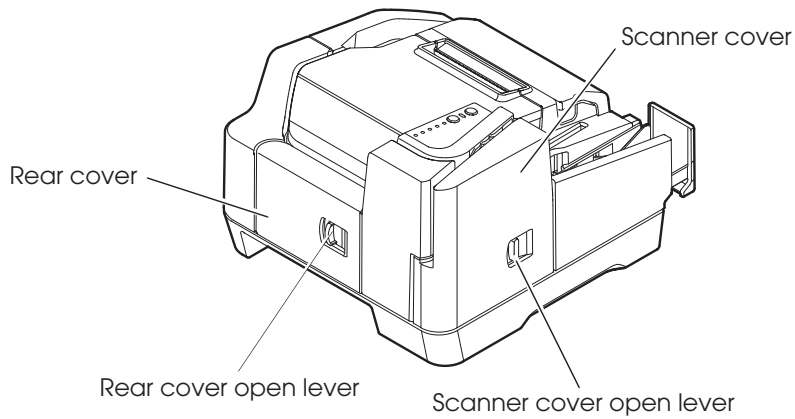
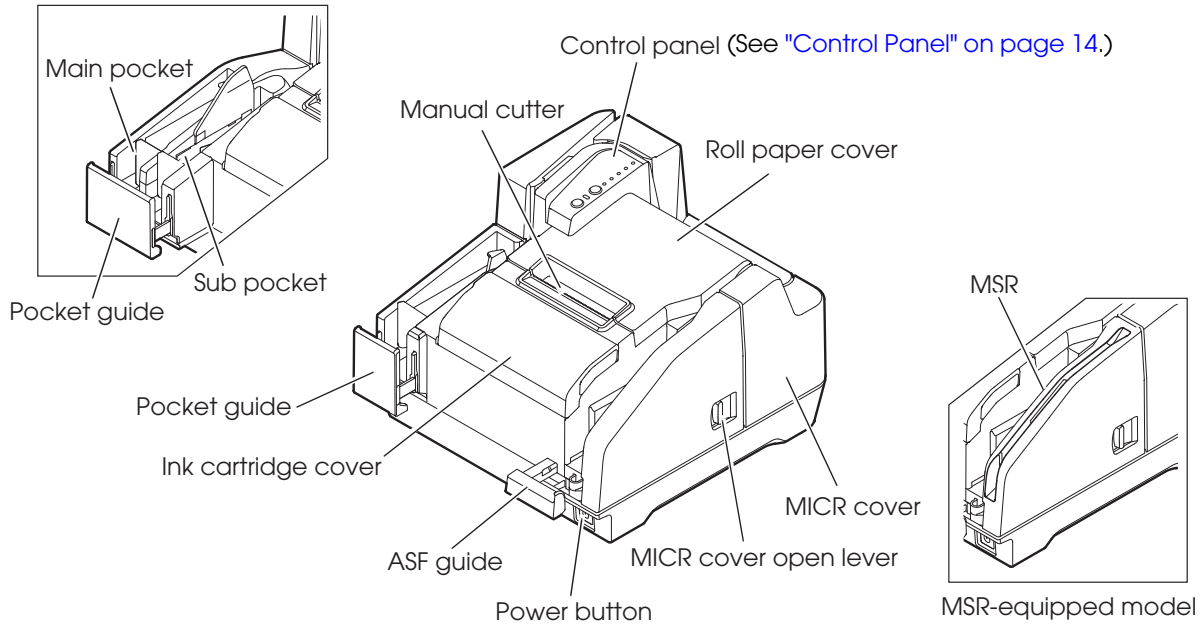

Power Button

Turns the product on or off.

CAUTION

Be sure not to turn off the product or open the covers while the Power LED is flashing.

Control Panel

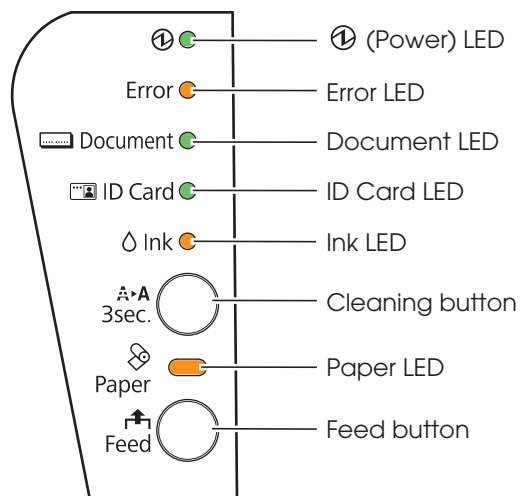

Power LED (Green)

- Lights when the power supply is on.
- Flashes rapidly while some operations such as turning power on, ink charging, or cleaning, are executed.
- Flashes slowly while turning power off.
- Goes out when the power supply is turned off.

Error LED (Orange)

- Lights when the product is offline (except during paper feeding using the Feed button, during self-test, and during ink-jet head cleaning).
- Flashes when an error occurs. (For details about the flash codes, see ["Error Status" on page 26.](#))
- Goes out during regular operation (online).

Document LED (Green)

- Lights when the product is ready to process cut sheet paper in the ASF or while the product is processing cut sheet paper.
- Flashes when the product is waiting for cut sheet paper insertion.
- Goes out except for the cases above.

ID Card LED (Green)

- Lights when ID card is set and the product is ready to process it.
- Flashes when the product is waiting for ID card insertion or removal.
- Goes out except for the cases above.

Ink LED (Orange)

- Lights when no ink cartridge is installed or it is time to replace the ink cartridge.
- Flashes when ink is low.
- Goes out when the ink cartridge is installed and remaining ink is enough.

Cleaning button

Pressing this button for 3 seconds or more starts the ink-jet head cleaning. (See "[Cleaning the Ink-Jet Head](#)" on page 82.)

Paper LED (Orange)

- Lights when the roll paper is out or almost out.
- Flashes when the product is waiting for test printing on the roll paper.
- Goes out when the remaining roll paper is enough.

Feed button

Pressing this button feeds the roll paper.

Connectors

All cables are connected to the connector panel on the lower rear of the product.

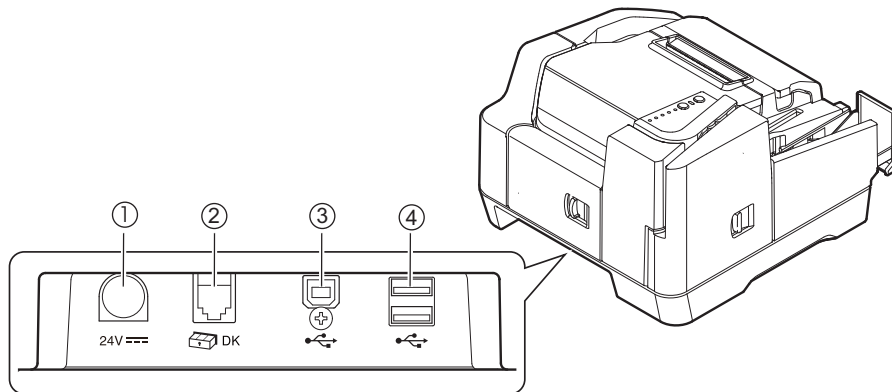

- Power supply connector (①): Connects the power supply unit.
- Drawer kick-out connector (②): Connects the cash drawer.
- USB connector (Type B) (③): Connects the product with the host computer.
- USB connectors (Type A)* (④): Connects USB devices.

* Factory option

Offline

The TM-S9000MJ automatically goes offline under the following conditions:

- During initialization after:
 - Power on (including resetting with the interface)
 - Removal of error causes
- When any of the following covers are opened:
 - Ink cartridge cover
 - Roll paper cover
 - MICR cover
 - Rear cover
 - Scanner cover
- While the roll paper is fed using the FEED button
- When no ink cartridge is installed
- When it is time to replace the ink cartridge
- During self-test
- During the ink-jet head cleaning
- When an error has occurred
- During macro command execution
- When the product stops printing on the roll paper due to a roll paper end

NOTE

For MSR equipped models, reading magnetic stripe card is possible, regardless of whether the product is online or offline.

Processing Modes for Cut Sheet Paper

The TM-S9000MJ has the following processing modes that are selectable with the driver in accordance with how you want to use the product with cut sheet paper.

- High-speed mode
- Confirmation mode (with overlap/without overlap)

NOTE For detailed information about processing modes, see the *TM-S9000MJ API Reference Guide*.

High-Speed Mode

This mode selects pockets and specifies whether to continue processing based on conditions specified prior to scanning.

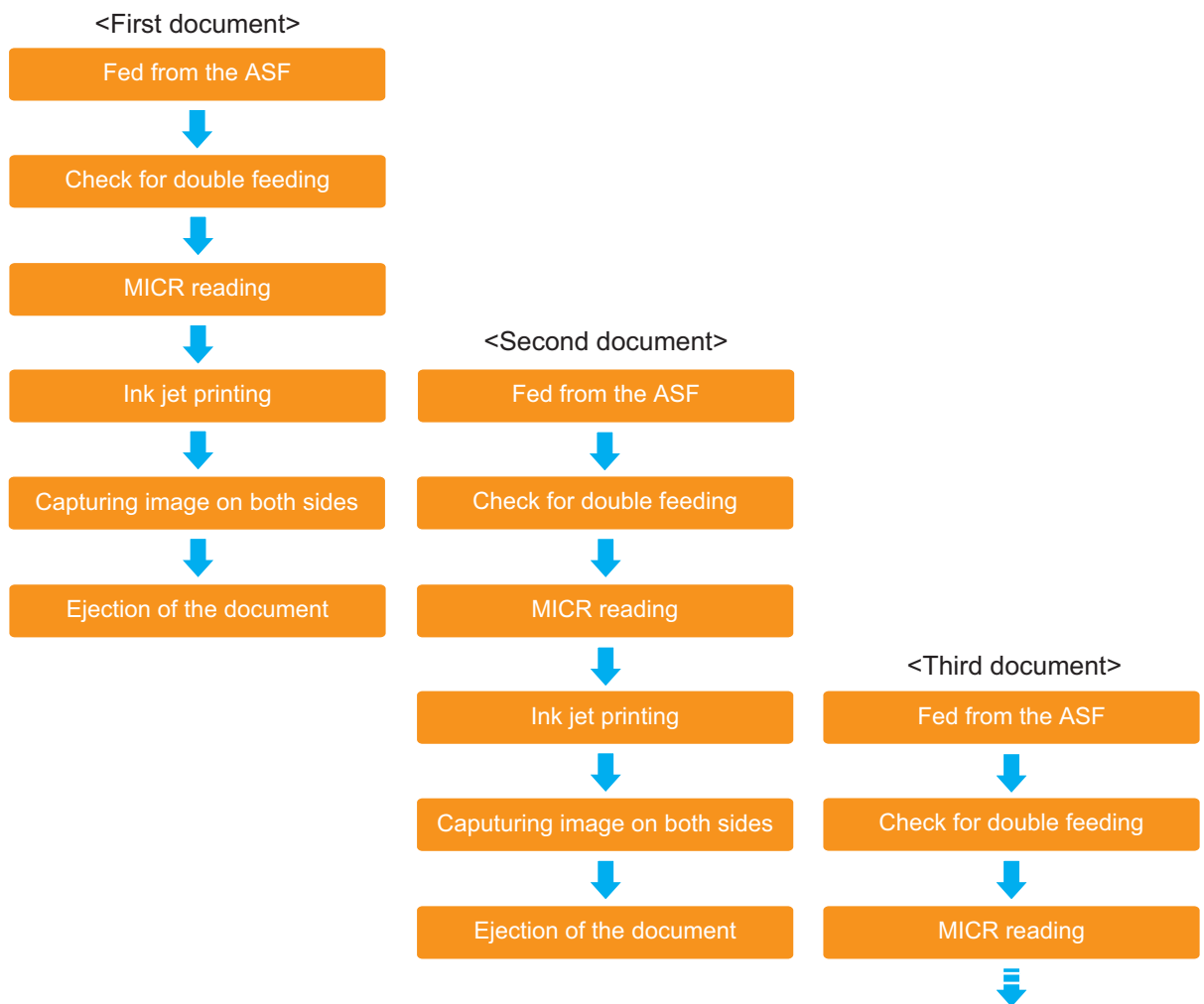

When ejecting into the sub pocket (only for two-pocket models)

When documents are sorted into the two ejection pockets, a document is fed backward to the pocket switching position and then ejected into a pocket if the ejection pocket is required to be switched and the document is long. In that case, the processing slows down.

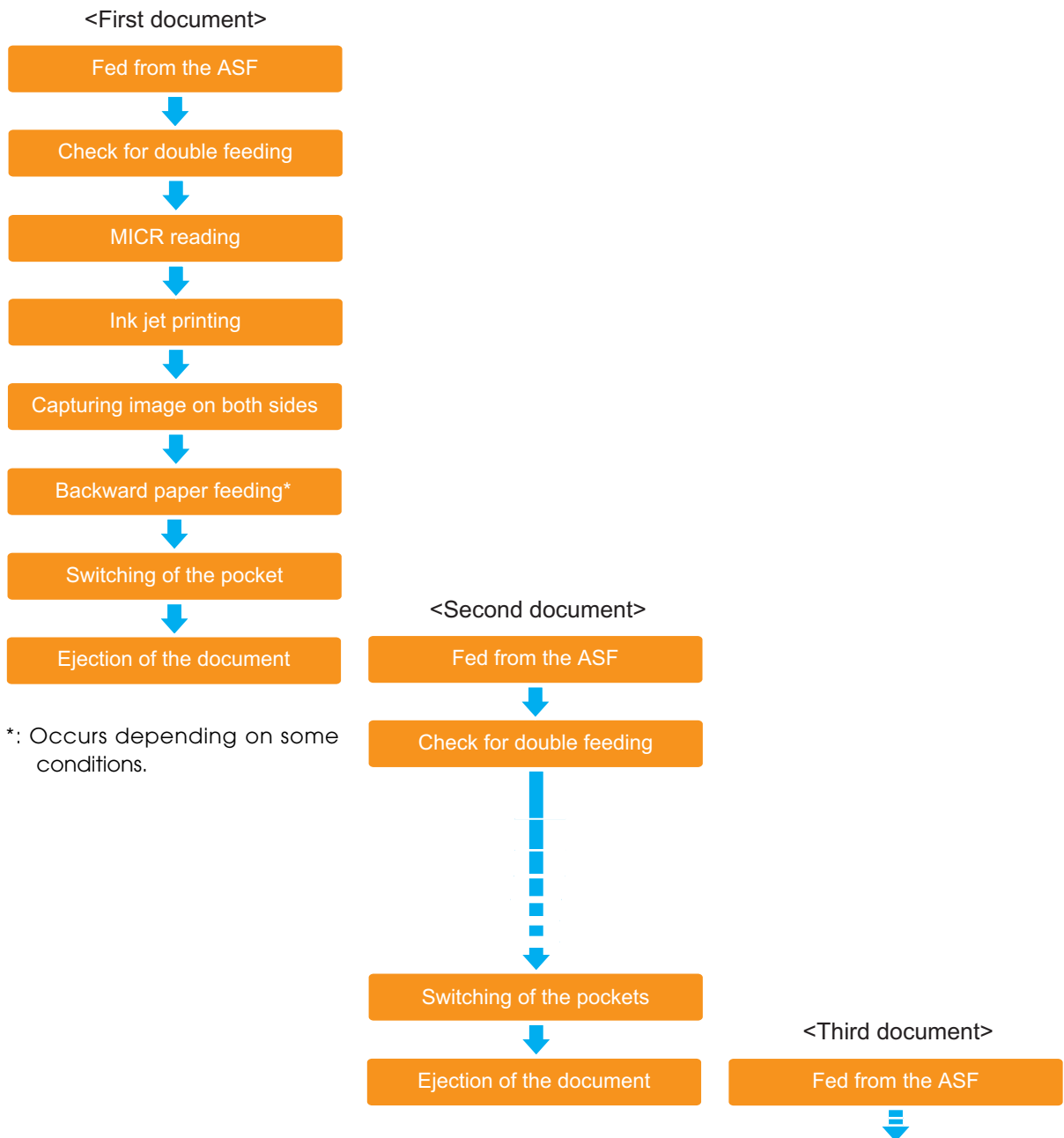

Confirmation Mode

This mode selects pockets and specifies whether to continue processing according to commands from the application for each scan.

Confirmation mode with overlap

The product starts feeding the next document while ejecting the current document into a pocket.

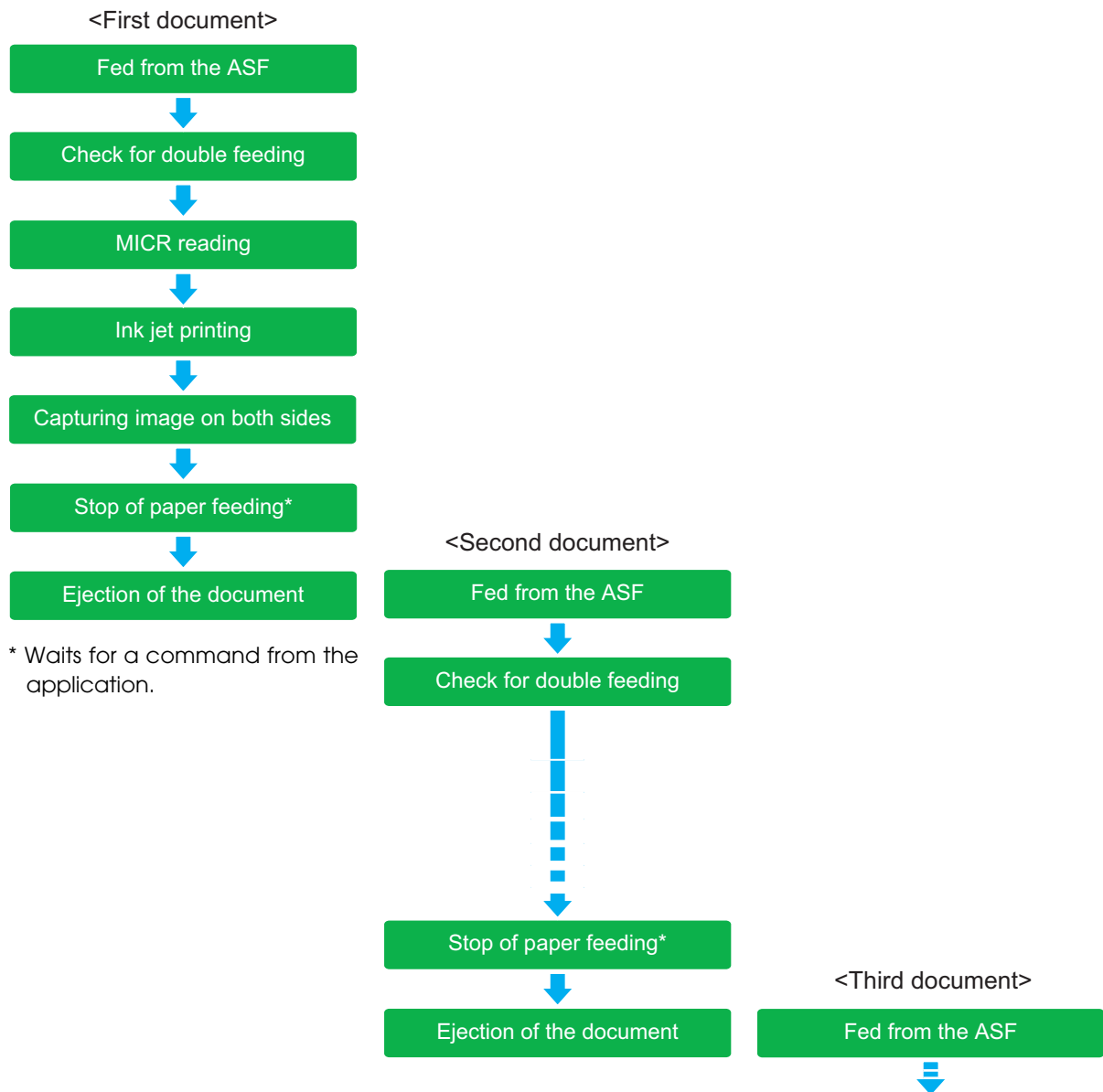

When ejecting into the sub pocket (only for two-pocket models)

When the two-pocket model receives a command to eject a document into a pocket, the processing slows down because it feeds the document backward to the pocket switching position and ejects it into a pocket.

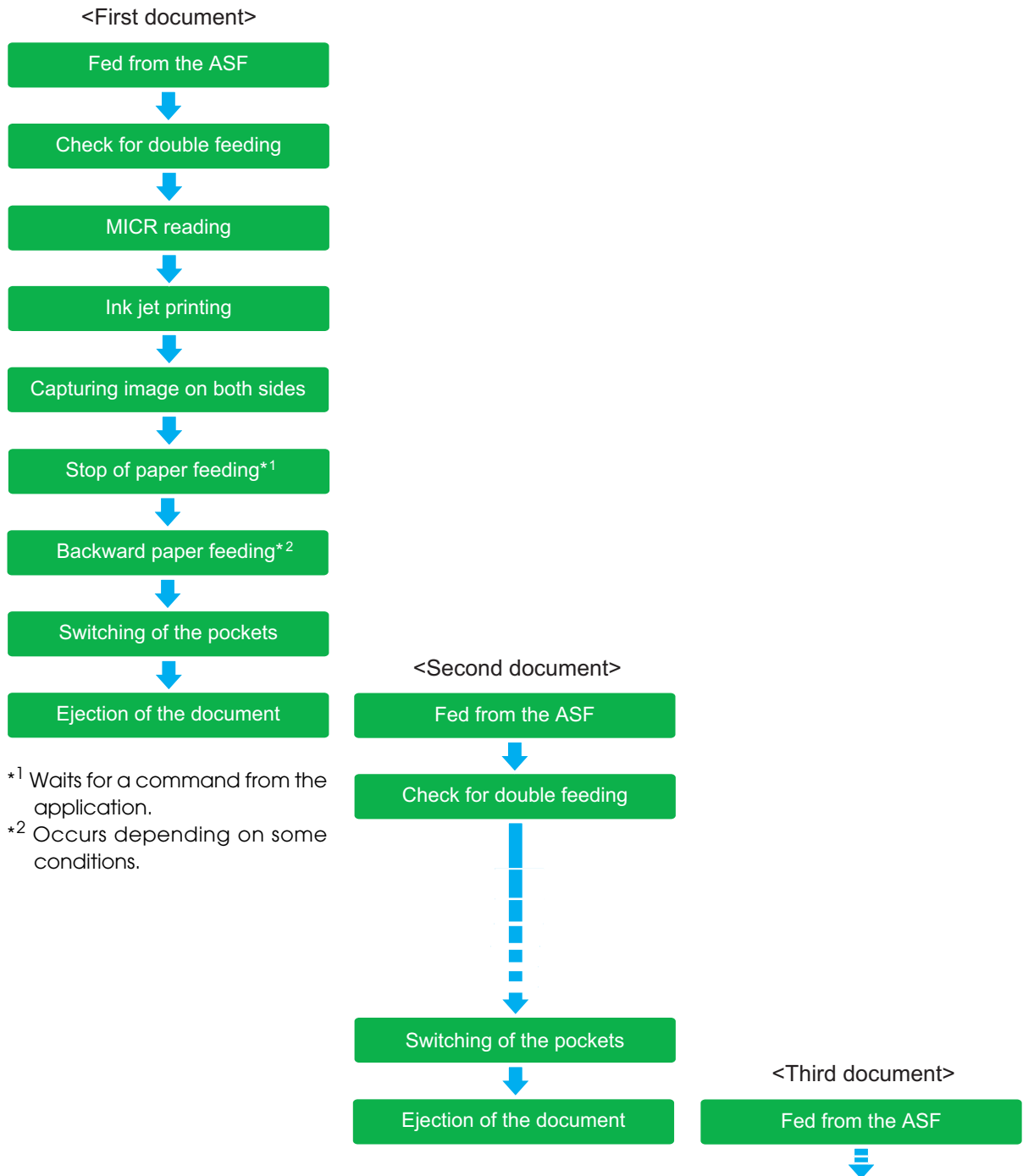

Confirmation mode without overlap

The product starts feeding the next cut sheet paper after the current cut sheet paper has been stored completely into the pocket.

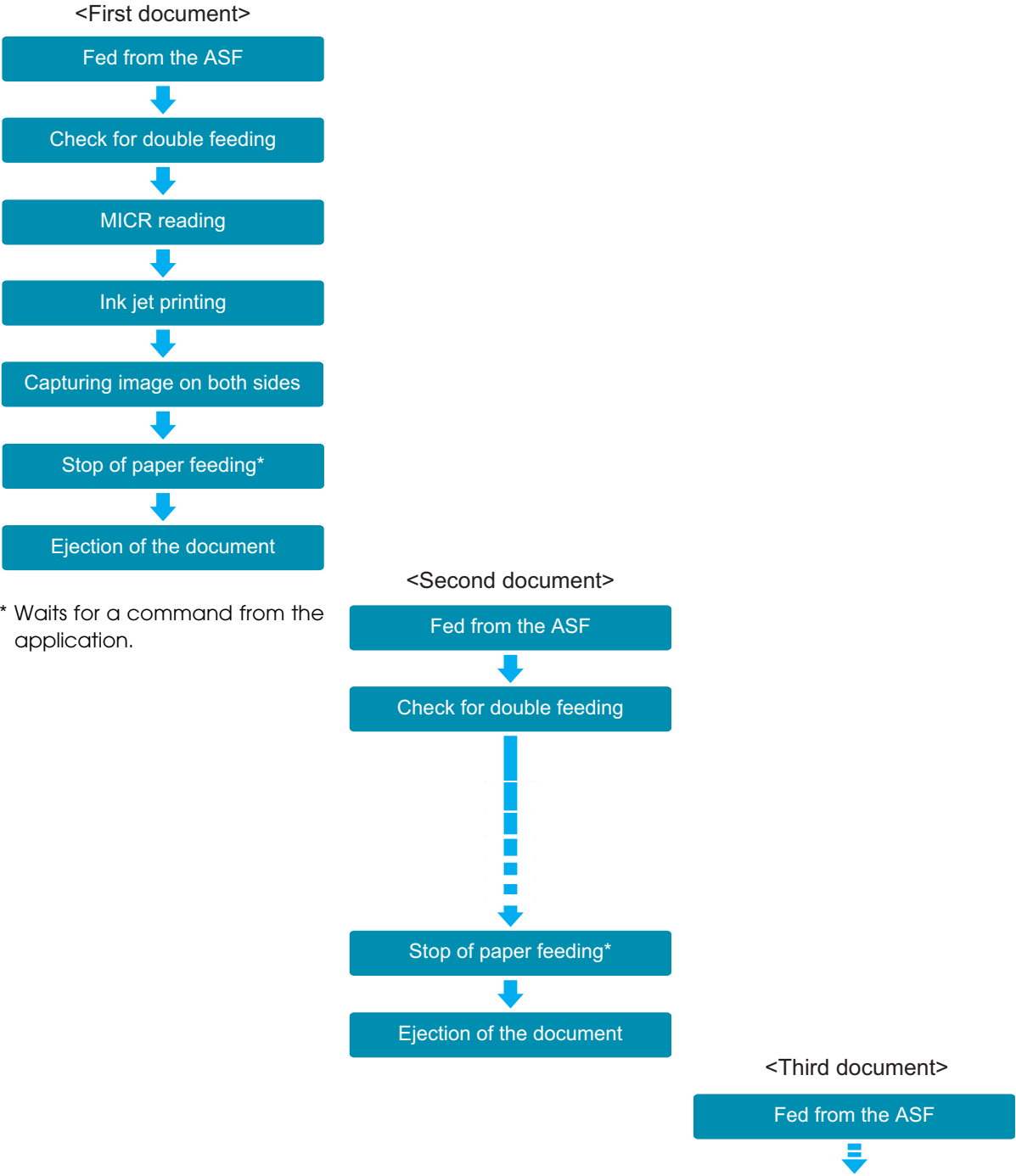

When ejecting into the sub pocket (only for two-pocket models)

When the two-pocket model receives a command to eject the document into the sub pocket, the processing slows down because it feeds the cut sheet paper backward to the pocket switching position and ejects it into the sub pocket.

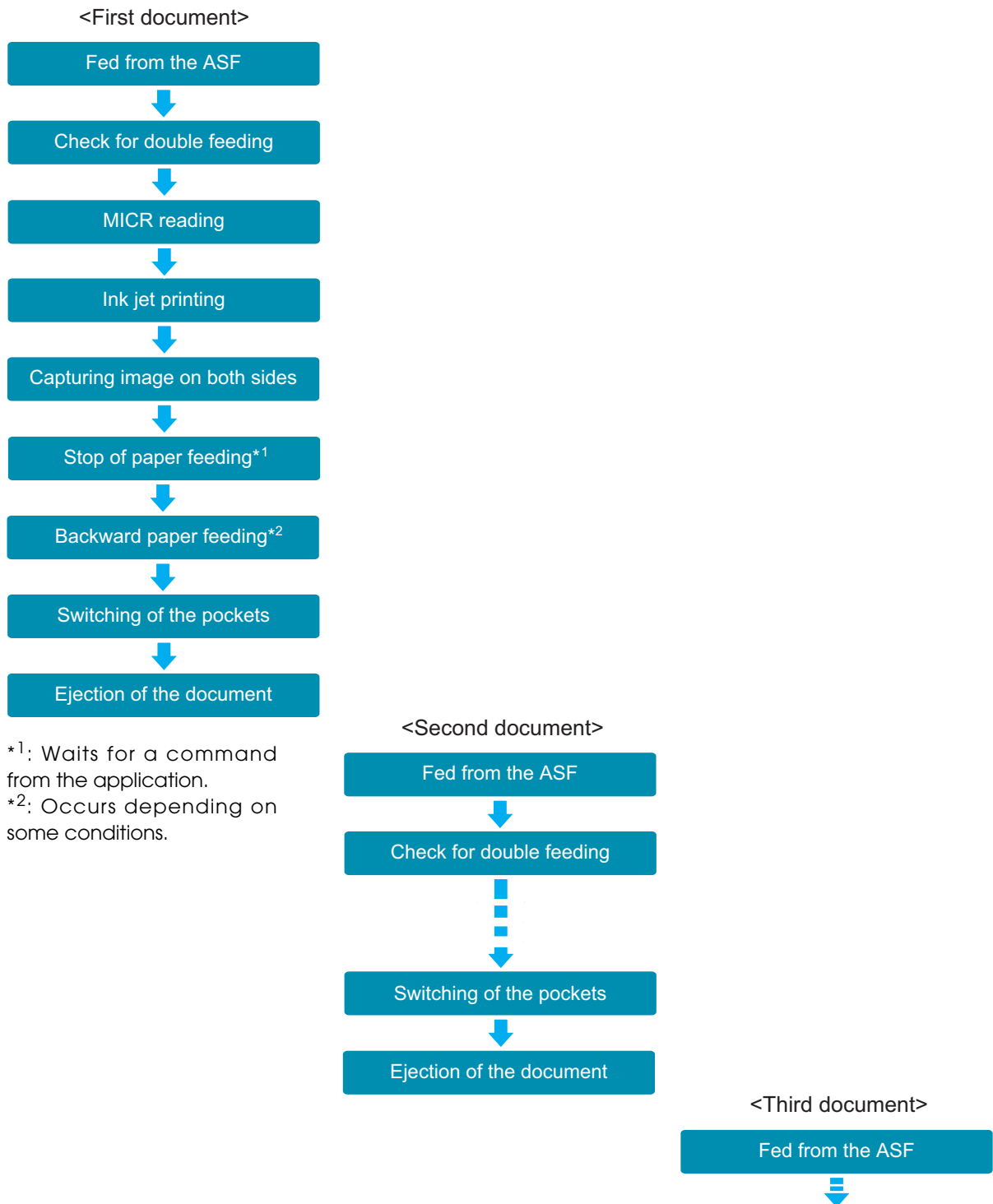

Selectable Functions for Processing Cut Sheet

The TM-S9000MJ has the following functions that are selectable with the driver in accordance with how you want to use the product with cut sheet paper. Settings with an application are also available for the pocket ejection and processing continuance in the confirmation mode.

- Pocket ejection (only for two-pocket models)
 - Ejects the document to the Main pocket
 - Ejects the document to the Sub pocket
 - Waterfall*
- Processing continuance
 - Continues processing
 - Ejects the document and stops processing
 - Stops processing without ejecting the document
- Electric endorsement
 - Performs electric endorsement
 - Does not perform electric endorsement

* When the ejection pocket is near-full, the documents are automatically ejected to the other pocket.

Processing Mode:

High-speed mode	This mode specifies whether or not to use Pocket ejection or Processing continuance depending on the conditions set before scanning starts. This allows the application to operate at high speed as it does not need to specify operations for the next document for each scan. These conditions can be judged by the host computer (processing in the driver) or by the firmware.
Confirmation mode	This mode specifies whether or not to use Pocket ejection or Processing continuance depending on the instructions from the application. If there are no instructions from the application, operations can also be performed by using the settings made beforehand.

Functions and Judgment Conditions to be Selected in Each Processing Mode:

Processing Modes	Judgment	Selectable Functions
High-speed mode	Judged by F/W	When judgments are made from the following conditions only. <ul style="list-style-type: none"> • Detecting double feeding • Detecting incorrect insertion • (Check paper) • Detecting magnetic waveform • Detecting external noise • Print result that exceeds the paper length
	Judged by Driver	The following conditions are judged at the same time as well as the conditions in the cell above. <ul style="list-style-type: none"> • “?” in MICR reading • IQA judgment • Barcode recognition result
Confirmation mode	Judged by Application	Functions are judged by application software

Processing speed limitation:

Processing Modes	Judgment	Description
High-speed mode	Judged by F/W	Since operations can be performed with judgment by the firmware, without judgment by the host computer, operations can be performed at a high speed. However, back feeding occurs when ejecting the document into the sub pocket for two-pocket models. Therefore, the speed decreases when the number of sub pocket ejections increases.
	Judged by Driver	Performance declines when the conditions need to be judged by the driver.
Confirmation mode	Judged by Application	When conditions for scanned images, MICR text strings, and so on are judged by the application, since the product waits for instructions from the application, the processing speed changes for each scan as the application returns instructions to the driver. Furthermore, performance changes depending on whether or not to overlap the next document upon instructions from the applications.



Error Status

When an error occurs, the printer stops operating, goes offline, and the Error LED flashes.

There are three possible error types: automatically recoverable errors, recoverable errors, and unrecoverable errors.

Automatically Recoverable Errors

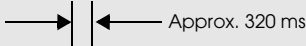
Printing is no longer possible when automatically recoverable errors occur. They can be recovered easily, as described below.







Error	Error description	Error LED flash code  Approx. 320 ms	Recovery measure
Roll paper cover open error* ¹	While printing on the roll paper, the roll paper cover was opened.		Close the roll paper cover.
Print head high temperature error* ²	The temperature of the print head is extremely high.		Recovers automatically when the print head cools.
Print head low temperature error* ²	The temperature of the print head is extremely low.		Recovers automatically when the print head warms.

*1 The memory switch must be set to auto recoverable error.

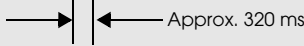
*2 If a drive circuit error occurs because of extreme temperatures, it is an unrecoverable error.

Recoverable Errors

Processing is no longer possible when recoverable errors occur. They can be recovered easily by sending an error recovery command from the driver after eliminating the cause of the error.







Error	Error description	Error LED flash code 	Recovery measure
Roll paper cover open error*	While printing on the roll paper, the roll paper cover was opened.		Recovers with a command with the roll paper cover closed.
Mechanism position error	The home position of the hopper or the pocket switching board cannot be detected.		Recovers with a command after the error cause is eliminated.
Cut sheet paper jam error	<ul style="list-style-type: none"> • The check is not ejected after feeding a specified amount of paper. • Feeding from the ASF failed. • A cut sheet paper/card jam was detected. • Too short/long paper was detected. 		Recovers with a command after the error cause is eliminated.
Cut sheet paper feed error	<ul style="list-style-type: none"> • Double feeding of cut sheet paper occurred. • Cut sheet paper was inserted upside down or back to front. • Selected that incorrect cut sheet paper feeding to cause an error in confirmation mode. • Data that is longer than the length of the cut sheet paper was specified. • Noise was detected during MICR reading. 		Recovers with a command after the error cause is eliminated.
Auto-cutter error	The home position of the auto-cutter cannot be detected.		Recovers after the error cause is eliminated.

* The memory switch must be set to recoverable error.

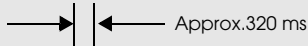
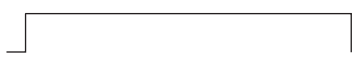
Unrecoverable Errors

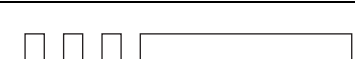
Processing is no longer possible when unrecoverable errors occur. The scanner must be repaired.

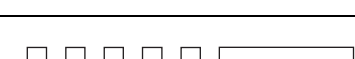
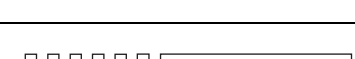
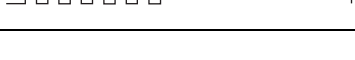
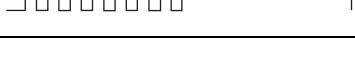
 CAUTION	Turn off the power immediately when unrecoverable errors occur.
---	--

Error	Error description	Error LED flash code 
Drive circuit error	<ul style="list-style-type: none"> Internal circuit does not work correctly. There is an abnormality in the thermistor. 	
Read/Write error	After R/W checking, the printer does not work correctly.	
High voltage error	The power supply voltage is extremely high.	
Low voltage error	The power supply voltage is extremely low.	
CPU execution error	The CPU executes an incorrect address.	
Communication device error	USB does not work correctly.	
IJ mechanism error	Ink jet print mechanism does not work correctly.	
Double feeding detector noise error	The double feeding detector detected a noise.	
Double feeding detector error	The double feeding detector does not work correctly.	
Maintenance error	<ul style="list-style-type: none"> The pump rotates more times than specified. The absorbed amount of the ink absorber is more than specified. 	

NV Memory (Non-Volatile Memory)

The printer's NV memory stores data even after the printer power is turned off. NV memory contains the following memory areas for the user:

- NV graphics memory
- User NV memory
- Memory switches
- Receipt Enhancement (R/E)
- User-defined page
- Maintenance counter

CAUTION

As a guide when you program applications, NV memory should be rewritten 10 or fewer times a day.

NV Graphics Memory

Graphics, such as logos to be printed on receipts, can be stored to enable high speed graphic printing.

Use the TM-S9000 Utility to register graphics. You can also print and confirm the registered graphics in the TM-S9000 Utility or NV graphics memory print mode.

NOTE

- For detailed information about the TM-S9000 Utility, see the *TM-S9000 Utility User's Manual*.
- For information about how to use the NV graphics memory print mode, see "[NV Graphics Print Mode](#)" on page 69.

User NV Memory

You can store and read text data for multiple purposes, such as for storing a note including customizing or maintenance information of the printer.

Memory Switches

With the memory switches, which are software switches for the printer, you can configure various settings of the printer.

For information about the memory switches, see "[Setting the Memory Switches and R/E](#)" on page 59.

R/E (Receipt Enhancement)

Graphics, such as logos, can be printed on top or bottom of receipts by setting R/E.

For information about R/E settings, see "[Setting the Memory Switches and R/E](#)" on page 59.

User-defined Page

You can store character data in the user-defined page (character code table: page 255) so that you can also print characters not resident in the printer.

Maintenance Counter

With this function, printer information, such as the number of lines fed, the count of thermal head energizing, and printer operation time after the printer starts working, is automatically stored in NV memory. You can read or reset the information with the TM-S9000 Utility or the API of the TM-S9000 Driver to use it for periodical checks or part replacement.



For information about maintenance counter, see "[Maintenance Counter](#)" on page 31.

Maintenance Counter

The TM-S9000MJ has the maintenance counter to get the following counts.

Counter	Counter type	Unit
Number of lines fed for roll paper	Resettable/Cumulative	Lines
Count of thermal head energizing	Resettable/Cumulative	Count
Number of lines fed for thermal head	Resettable/Cumulative	Lines
Number of head shots for ink jet (Column A)	Resettable/Cumulative	1000 shots
Number of head shots for ink jet (Column B)	Resettable/Cumulative	1000 shots
Count of pump motor operations	Resettable/Cumulative	Count
Count of autocutter drive	Resettable/Cumulative	Count
Count of ASF feeding	Resettable/Cumulative	Count
Count of cut sheet paper scanning	Resettable/Cumulative	Count
Count of card scanning	Resettable/Cumulative	Count
Count of magnetic ink character read	Resettable/Cumulative	Count
Count of pocket switch	Resettable/Cumulative	Count
Count of hopper open/close	Resettable/Cumulative	Count
Duration of product operation	Resettable/Cumulative	Hours

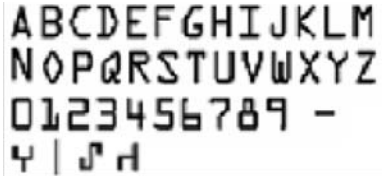
Product Specifications

Autocutter	Cutting method	Scissors type with separated blades
	Cutting type	Partial cut (cutting with one point left edge left uncut)
ASF paper supply		Number of sheets that can be loaded: 100 sheets or fewer (when the paper thickness is 0.13 mm or less). However, the total thickness must be 13 mm or less including warps.
Pocket storage	One-pocket model	100 sheets or fewer (when the paper thickness is 0.13 mm or less). However, the total thickness must be 13 mm or less including warps.
	Two-pocket model	Main pocket: 100 sheets or fewer (when the paper thickness is 0.13 mm or less). However, the total thickness must be 13 mm or less including warps.
		Sub pocket: 50 sheets or fewer (when the paper thickness is 0.13 mm or less). However, the total thickness must be 6.5 mm or less including warps.
MICR reader	Reading method	Permanent magnetic bias
	Supported fonts	E13B, CMC7 (Alphabetic characters are not supported.)
	Recognition rate	99% or more (at 25°C {77°F} using check paper conforming to ANSI standards)
OCR/ barcode reader	Supported OCR fonts	E13B, CMC7 OCR A  <p>OCR B (The characters, %, /, and & are available by driver setting.)</p> 
		Supported barcode fonts

Interface	USB (Type A*/Type B) (compliance: USB 2.0 communication speed: Hi-Speed (480 Mbps)/Full-Speed (12 Mbps))
Ink cartridge	Exclusive ink cartridge: SJIC18(K)
	Color of ink: Black
Power supply	Specified AC adapter
Operating voltage	DC 24 V \pm 7%

* USB (Type A) connector is a factory option.



The specified processing speed is not achievable when using USB Full-Speed.

Printing Specifications

Cut sheet paper printing

Printing method		Line ink jet printing with ink jet head
Nozzle arrangement		360 nozzles in 2 lines
Dot density		180 × 180 dpi
Printing direction		Fixed stroke control
Print height		50.80 mm {2.00 in}
Printable lines	Font A	12 lines maximum
	Font B	16 lines maximum
Line spacing*		Default: Approx. 4.23 mm {1/6 in}
Print width		100 to 215 mm {3.94 to 8.46 in} (depends on the paper width)
Characters per line	Font A	59 to 126 (depends on the paper width)
	Font B	78 to 169 (depends on the paper width)
Character spacing*	Font A	0.28 mm {0.01 in} (2 dots)
	Font B	0.28 mm {0.01 in} (2 dots)
Maximum printing speed		Approx. 800 mm/s {31.50 in/s} (The printing speed depends on the type of the image to obtain.)

dpi: dots per inch (number of dots per 25.4 mm {1.00 in})

* Programmable by control command.

Roll paper printing

Printing method		Thermal line printing
Dot density		180 × 180 dpi
Printing direction		Unidirectional with friction feed
Print width		72 mm {2.83 in}, 512 dot positions
Characters per line	Font A	42
	Font B	56
Character spacing*	Font A	0.28 mm {0.01 in} (2 dots)
	Font B	0.28 mm {0.01 in} (2 dots)
Maximum printing speed		Text printing with embedded fonts: 300 mm/s {11.81 in/s}
Paper feed speed		Approx. 200 mm/s {7.87 in/s} (continuous paper feeding)
Line spacing*		Default: 4.23 mm {1/6 in}

dpi: dots per inch (number of dots per 25.4 mm {1.00 in})

* Programmable by control command.

NOTE

- The printing speed above is the value when the product prints with the standard print density level at 24 V and 25°C. However, the printing speed changes automatically depending on the condition of the supply voltage or the head temperature.
- The maximum printing speed above may not be achieved depending on the type of interface, the setting of data transmission speed, and the combination of control commands.
- If the data transmission speed is slower than the maximum printing speed, the printing speed may fluctuate and there may be some cases where the print result becomes shaded and/or dot displacement in paper feeding occurs.
- If the data transmission speed is much slower than the maximum printing speed, intermittent printing will occur and white lines will be formed when printing graphics.

Character Specifications

Number of characters	Alphanumeric characters	95 characters
	Extended graphics	128 characters × 11 pages (including user-defined page)
	International characters	16 sets
Character structure	Font A	12 × 24 (including 2-dot horizontal spacing)
	Font B	9 × 17 (including 2-dot horizontal spacing)
Character size (W × H)	Font A	Standard: 1.41 × 3.39 Double-height: 1.41 × 6.77 Double-width: 2.82 × 3.39 Double-height/Double-width: 2.82 × 6.77
	Font B	Standard: 0.99 × 2.40 Double-height: 0.99 × 4.80 Double-width: 1.98 × 2.40 Double-height/Double-width: 1.98 × 4.80
Characters per line	Font A	Standard: 42 Double-height: 42 Double-width: 21 Double-height/Double-width: 21
	Font B	Standard: 56 Double-height: 56 Double-width: 28 Double-height/Double-width: 28

Space between characters is not included.

Characters can be scaled up to 64 times as large as the standard sizes.

When using Font B with a font style such as emphasized, some words may be hard to read. Check the font style in advance when using Font B.

Scanner Specifications

Image Scanner		CIS (Contact Image Sensor)
Resolution (H × W)	Cut sheet paper	300 × 300 dpi, 240 × 240 dpi, 200 × 200 dpi, 120 × 120 dpi, 100 × 100 dpi
	ID cards	600 × 600 dpi, 300 × 300 dpi, 200 × 200 dpi
Graduation		Binary (black and white)* ¹ , 256-level grayscale, 24-bit color, Binary and 256-level grayscale using infrared light source
Data compression format	256-level grayscale 24-bit color	JPEG
	Binary (black and white)	CCITT/group 4
Data format	Binary (black and white)* ²	TIFF* ³ , BMP
	256-level grayscale	TIFF, JPEG, BMP, Raster
	24-bit color	TIFF, JPEG, BMP
	Infrared light source image	Binary (black and white): TIFF, BMP 256-level grayscale: TIFF, JPEG, BMP, Raster
Image size (H × W)		Max. 109.728 mm {4.32 in}* ⁴ × Max. 255.0 mm {10.04 in}* ⁵ (When using the driver's auto size function, the scanning area is approximately equivalent to the document size.)
Image quality		Complies with IQA (Image Quality Assurance) formulated by FSTC (Financial Services Technology Consortium).
Deskewing images		Deskews the image on the skewing document, according to the TM-S9000 driver settings.
Auto size adjustment		Crops the image and adjusts the size to the document size, according to the TM-S9000 driver settings.
Scanning speed	Cut sheet paper	Approx. 800 mm/s {31.50 in/s}, Approx. 600 mm/s {23.62 in/s}, Approx. 400 mm/s {15.75 in/s}, Approx. 240 mm/s {9.45 in/s} (Depends on the image to read)
	ID card	Approx. 118 mm/s {4.65"/s}, Approx. 88mm/s {3.46"/s} (Depends on the image to read)

Cut sheet paper		See "Cut sheet paper" on page 39.
ID card	Type	ISO/IEC7810 compliant (without embossed effect)
	Size (H × W)	53.92 to 54.18 mm {2.12 to 2.13 in} × 85.47 to 85.90 mm {3.36 to 3.38 in}
	Thickness	0.5 to 0.84 mm {0.02 to 2.13 in}
	Warpage	2 mm maximum (ISO/IEC7810)

dpi: dots per inch (25.4 mm)

*¹ Binary is supported by cut sheet paper only.

*² The background on the check is eliminated automatically when the TM-S9000 driver binarizes grayscale image.

*³ The TIFF format of resolution 200 dpi, binary, CCITT-Group 4 compression complies with ANSI X9.100-181-2007.

*⁴ Image sensor height is 109.728 mm {4.32 in}. As the image sensor attaching portion is included, the actual obtainable height of the image is maximum 107.358 {4.23 in}.

*⁵ Maximum document width in which image can be obtained is maximum 235 mm {9.25 in} + margin to ensure image obtainment.

MSR (Factory Option)

Recognition method	Two-frequency coherent phase (F2F)
Supported magnetic format	ISO 7811-6, AAMVA, previous California driver's license
Card specifications	ISO/IEC7810 compliant
	Size (H × W): 53.92 to 54.18 mm {2.12 to 2.13 in} × 85.47 to 85.90 mm {3.36 to 3.38 in}
	Thickness: 0.76 to 0.84 mm {0.03 + 0.033 in}
	Warpage: 1.5 mm {0.06 in}
Recognition rate	99.5% or more

Paper Specifications

Cut sheet paper

Type	Normal paper (single-ply only)
Size (H × W)	60 to 120 mm {2.36 to 4.72 in} × 120 to 235 mm {4.72 to 9.25 in}
Thickness	0.075 to 0.2 mm {0.003 to 0.008 in} (single-ply only)
Weight	60 to 120 g/m ² {16 to 32 lb}

CAUTION

- Make sure that the paper has no curl, folds (especially at the top edges), warps, or wrinkles. Otherwise a paper jam may occur.
- Since the paper sensors use a reflective photo sensor, do not use paper that has holes, translucency, or areas whose reflection ratio is less than 40% in the area shown in the figure below.

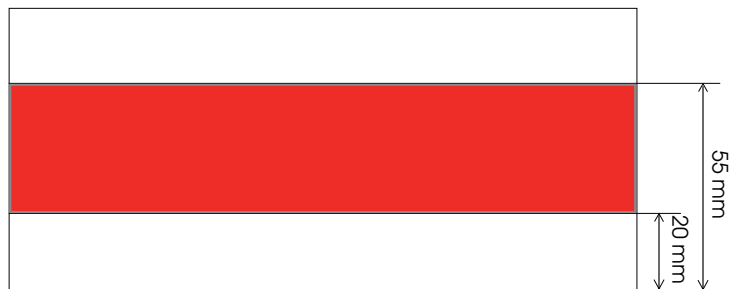

- Do not insert paper that has clips, staples, or other objects. Doing so may cause a paper jam, MICR reading error, or damage to the MICR head or scanner head.
- The paper sensors ignore the range indicated in the figure below for the guide holes in fan-folded paper.

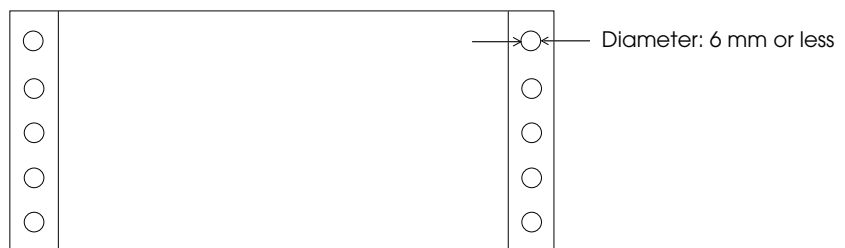

Roll paper

Paper type		Specified thermal paper
Paper size	Roll paper diameter	83 mm {3.27 in} maximum
	Roll paper core	Inside: 12 mm {0.47 in}
		Outside: 18 mm {0.71 in}
		Width: Must be the same as the paper width or less than the paper width by 1 mm.
Take-up roll paper width		80 + 0.5/-1.0 mm {3.15 + 0.02/- 0.04 in}
Paper width		79.5 ± 0.5 mm {3.13 ± 0.02 in}
Specified roll paper type		NTP080-80 (Original paper: TF50KS-E (Nippon Paper Industries Co., Ltd.)) In Japan: Nakagawa Manufacturing Co., Ltd. In U.S.A.: Nakagawa Mfg. (USA) Inc. In Europe: Nakagawa Mfg. (Europe) GmbH In Southeast Asia: N.A.K. Mfg. (Malaysia) SDN BHD
Specified original paper type		TF50KS-E, TF60KS-E (NIPPON Paper Industries Co., Ltd.) PD150R, PD160R, PD190R (OJI Paper Mfg. Co., Ltd.) P220AGB-1 (Mitsubishi Paper Mills Limited.) P30023, P31023, P35023 (Kanzaki specialty Papers) AF50KS-E (Jujo Thermal Oy) F5041 (Mitsubishi HiTec) KT55F20, KT48F20 (Koehler Paper Group)

CAUTION

- Paper must not be pasted to the roll paper core.
- If paper other than the specified paper is used, serious problems may occur, such as the print head may be damaged, reliability of the product may decrease, or the print quality may be poor.
- It is recommended to avoid using preprinted thermal paper. If such paper must be used, conduct preprinting test under the conditions (type of ink/print conditions) recommended by the paper manufacturer and confirm that no faulty printing, print density, or any other problems occur before you use it for actual printing.

Printable Area

Cut sheet paper

When the printing start position is set from the top of the paper

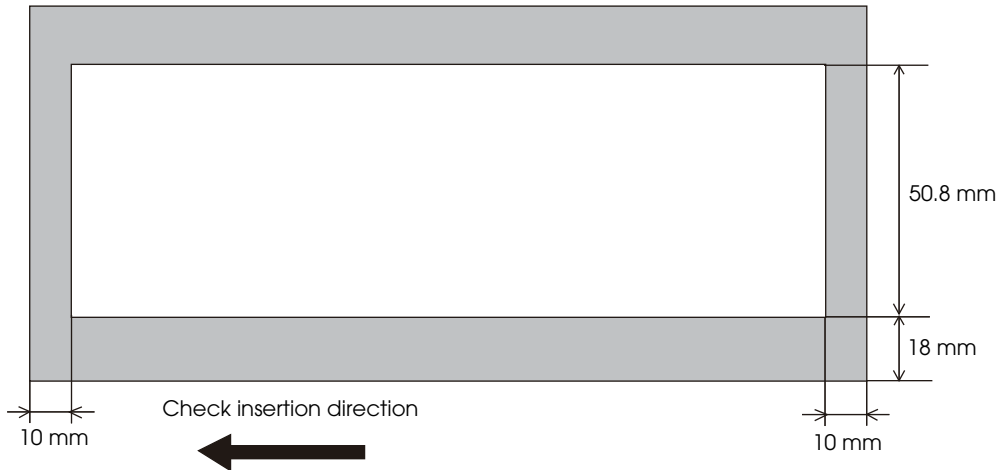

When the printing start position is set from the end of the paper

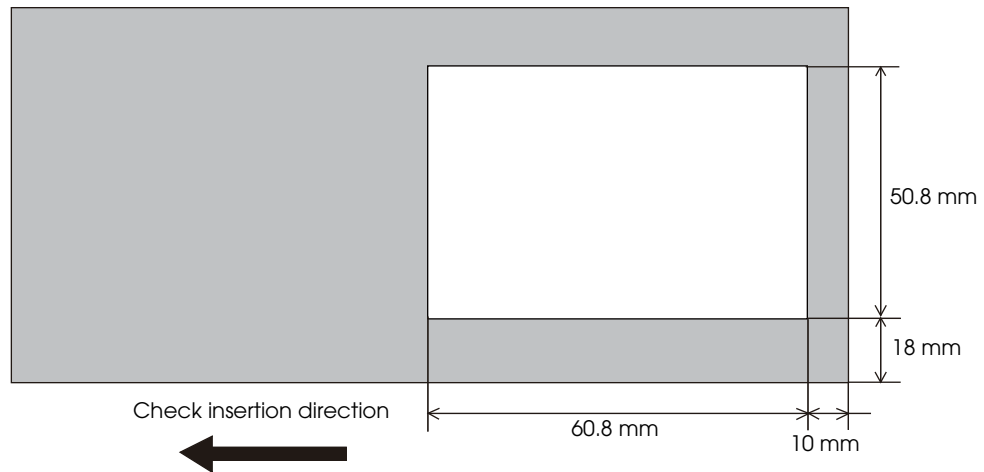

CAUTION

In the area that is 40 mm away from the end of the paper, print may be deformed.

Roll paper

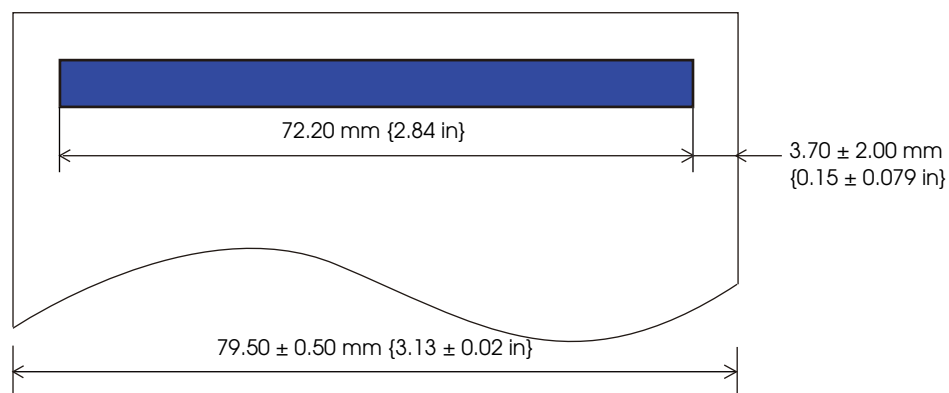

All the numeric values are typical.

Printing and Cutting Positions for Roll Paper

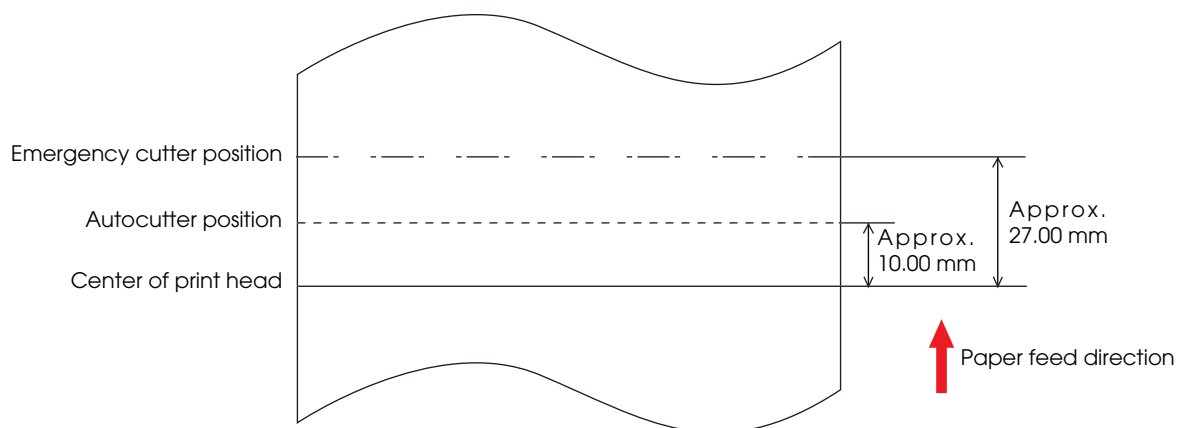

All the numeric values are typical.

CAUTION

- Numeric values used here are typical values; the values may vary slightly as a result of paper slack or variations in the paper. Take this into account when setting the cutting position of the autocutter.
- The cut paper may be pulled at the uncut edge when it is removed, causing reduced printing pitch for the first line of the next receipt. To prevent dot displacement, after cutting, feed paper approximately 1 mm {14/360 in} or more before printing.
- When operating the autocutter after leaving the product unused for some time, feed paper 40 mm {1.57 in} or longer to prevent paper jams in the autocutter unit.

Scannable Area

Cut sheet paper

Image scanning may not be possible in the area **a** and **b** in the figures below. The quality of the scanned image may be decreased in the area **c**.

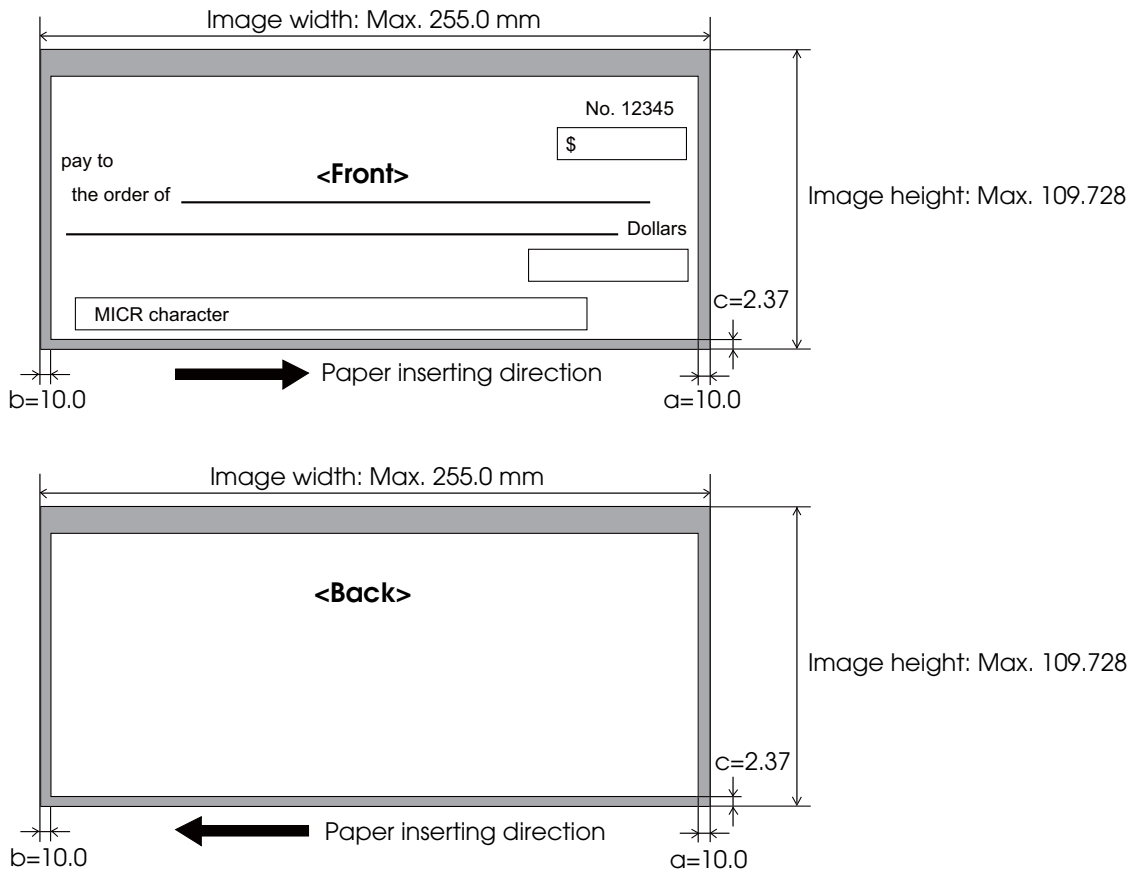

All the numeric values are typical,

ID card

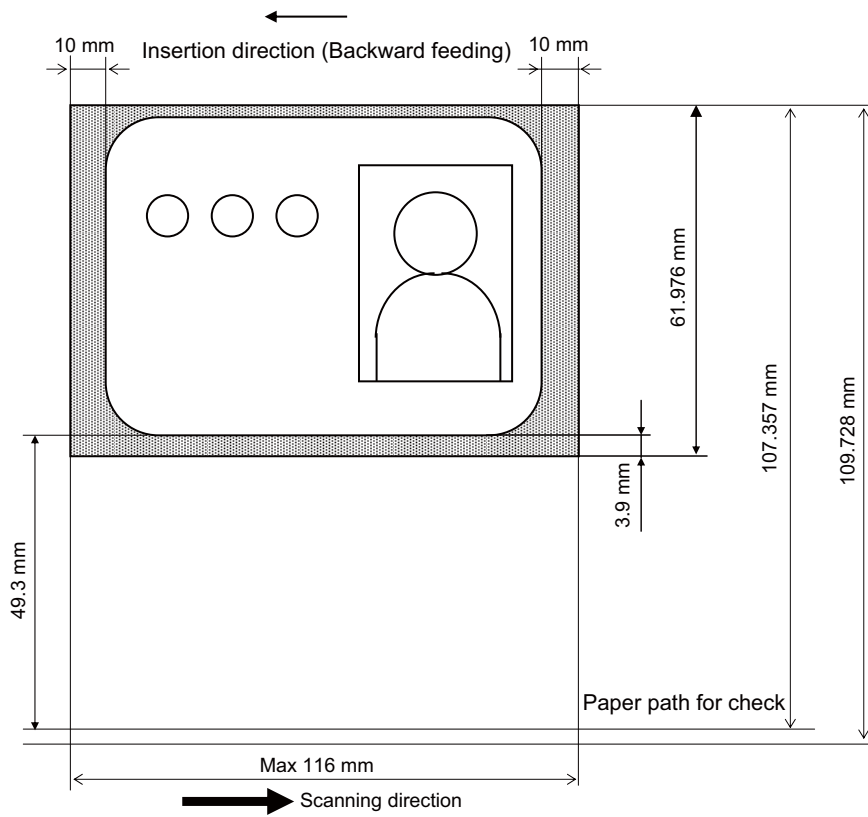

MICR Readable Area

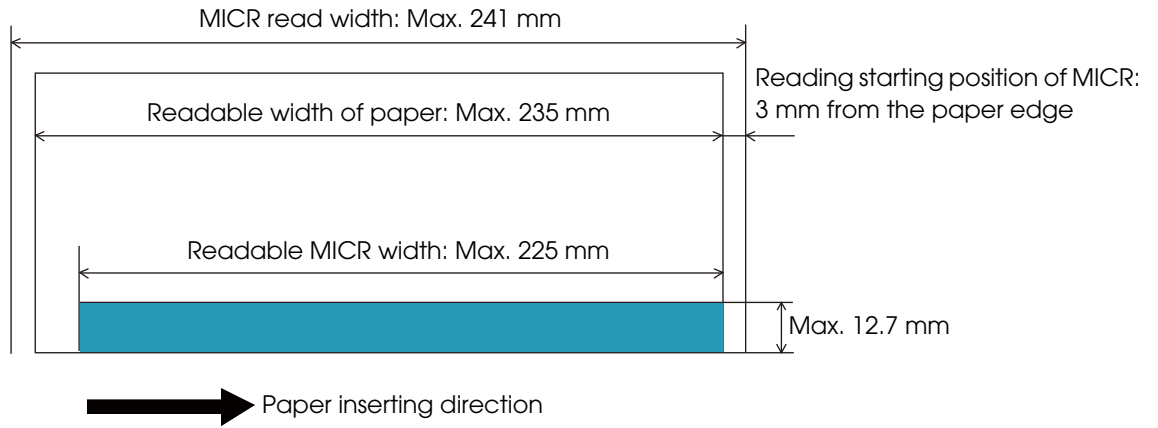

Area for Electric Endorsement

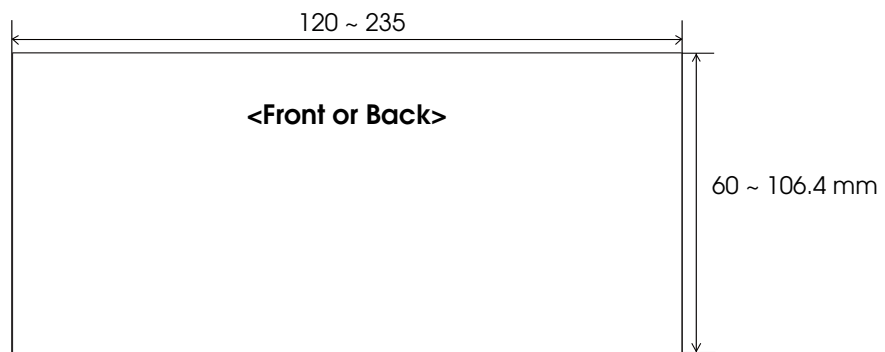

(Units: mm)

Environmental Conditions

Temperature/ humidity	Operating	10 ~ 35°C {50 ~ 95°F}, 20 ~ 80% RH without condensation (See the operating temperature and humidity range below.)
	Storage (Factory packing)	-20 ~ 60°C {-4 ~ 140°F}, 5 ~ 85% RH without condensation (120 hours or less at -20 {-4°F} or 60°C {140°F})
	Maximum absolute rated temperature	70°C {158°F} (This temperature must never be exceeded during operation or storage.)
		<p>The graph plots Humidity (%) on the y-axis (ranging from 20 to 80) against Temperature (°C) on the x-axis (ranging from 10 to 35). A blue shaded area represents the operating conditions. The area is bounded by a horizontal line at 20% RH from 10°C to 27°C, a horizontal line at 80% RH from 10°C to 27°C, a vertical line at 27°C from 20% to 55% RH, a vertical line at 35°C from 20% to 55% RH, and a diagonal line connecting (27, 80) to (35, 55). Dashed lines indicate the coordinates of these points.</p>

Reliability

Cut sheet paper unit	Life	including reading of checks and ID cards	2 million sheets
		ASF	2 million sheets
		Print head	6 billion shots/nozzles
	MTBF		180,000 hours
	MCBF		4,940,000 processes
Roll paper unit	Life	Printer mechanism (excluding the print head and autocutter)	20 million lines (printing): when printing 10 lines and feeding 5 lines is repeated with 4.23 mm line spacing.
		Print head	150 million pulses, 150 km
		Autocutter	2 million cuts: when using specified original paper type PD150R, PD160R.
	MTBF		360,000 hours
	MCBF		96 million lines

External Dimensions and Mass

The values below are when the pocket guide is fully pulled out.

One-pocket model

Height

Approximately 177.0 mm {6.97 in}

Width

Approximately 250.0 mm {9.84 in}

Depth

Approximately 374.8 mm {14.76 in}

Mass

Approximately 5.0 kg {11.00 lb}

Two-pocket model

Height

Approximately 177.0 mm {6.97 in}

Width

Approximately 275.0 mm {10.83 in}

Depth

Approximately 409.8 mm {16.13 in}

Mass

Approximately 5.0 kg {11.00 lb}

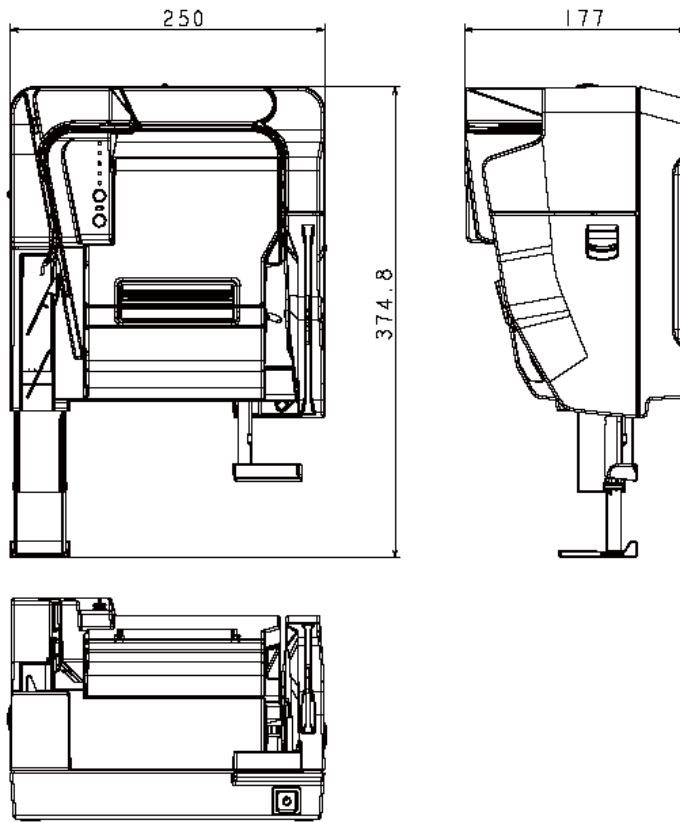

(Unit: mm)

Setup

This chapter describes setup and installation of the product.

Flow of Setup

This chapter consists of the following sections along with the setup flow of the product.

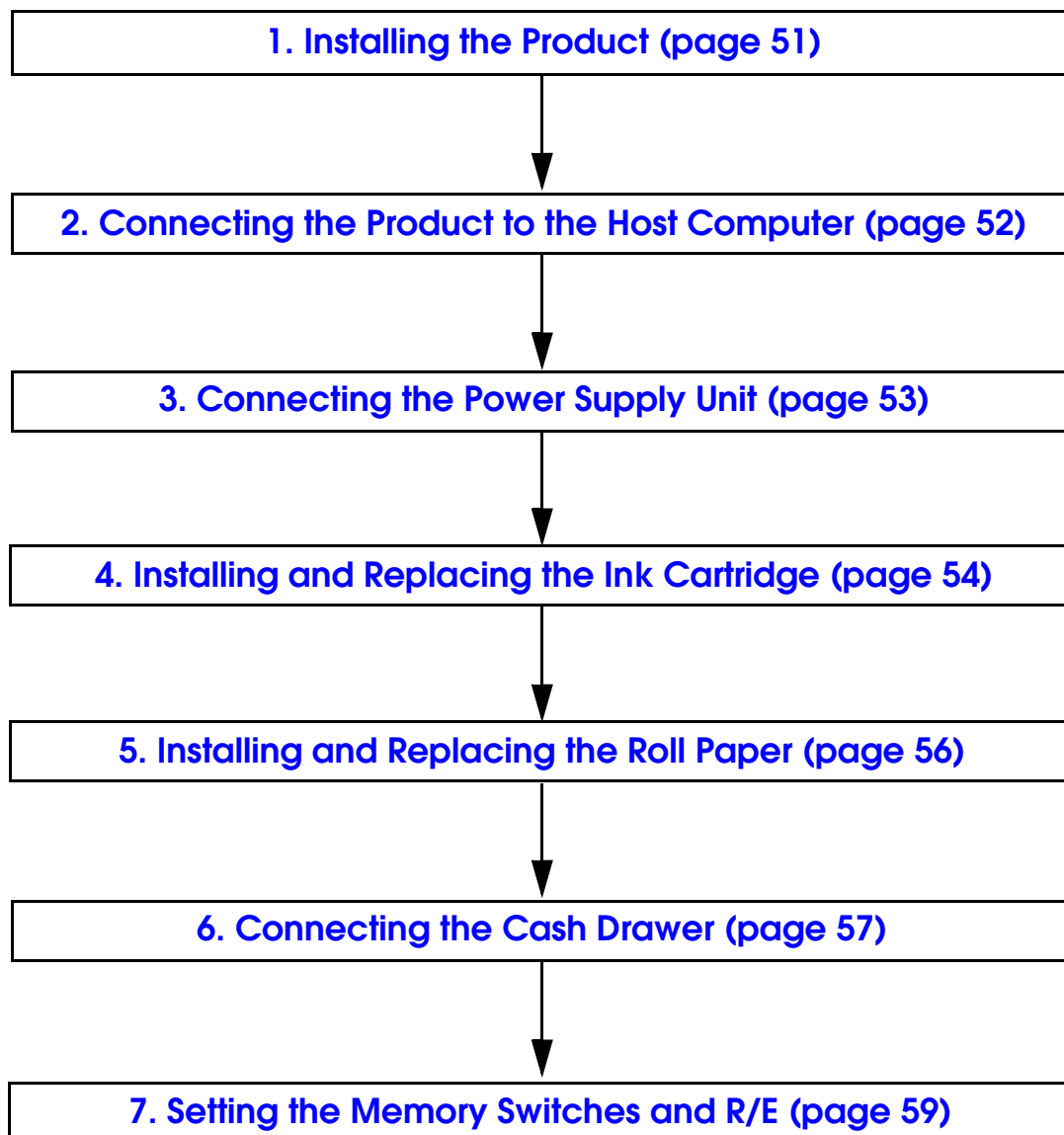

Installing the Product

Important Notes on Installation

- When carrying the product, lift the product holding the indents on both lower sides of the product.

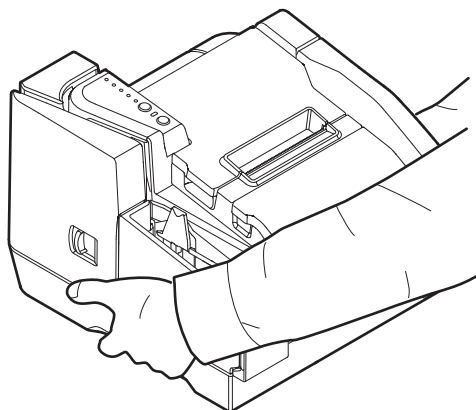

- Install the product horizontally.
- Make sure that the product is not subjected to any impact or vibration.
- Do not place the product near any magnetic fields to avoid decreasing the MICR recognition rate. Especially, when you install the product near a display device, check the recognition rate of the MICR reader.
- Leave enough space around the product to open the covers, the pocket guide, and the ASF guide.
- To prevent a paper jam, do not prevent paper from being ejected from the paper exit.
- Make sure cords and foreign objects are not caught in the product.
- Do not put any food or drink on the product case.
- Remove the cushions in the product and fixing tape before use.

Connecting the Product to the Host Computer

Follow the steps below to connect the product to a host computer.

CAUTION

- Be sure to install the driver before connecting the product to the host computer.
- Be sure to use the USB cable that is included with the product.

- 1 Connect the USB cable to the USB (Type B) connector.

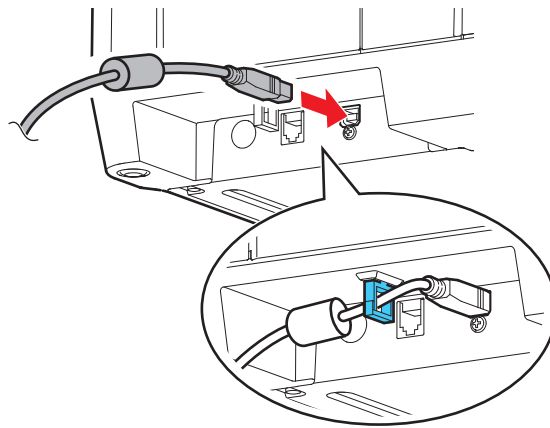

CAUTION

Fix the USB cable with the cable hook to prevent the USB cable from falling off.

- 2 Connect the USB cable to the host computer.

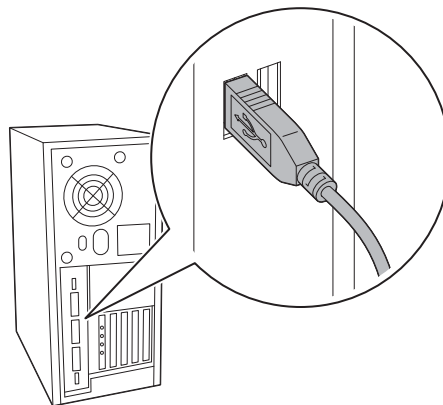

Connecting the Power Supply Unit

Follow the steps below to connect the power supply unit to the product.



- **Be sure to use the specified AC adapter only.**
Connection to an improper power source may cause fire or shock.
- **Should a fault ever occur in the AC adapter immediately turn off the power to the product and remove the power supply cable from the wall socket.**

- 1 Connect the AC cable to the AC adapter.

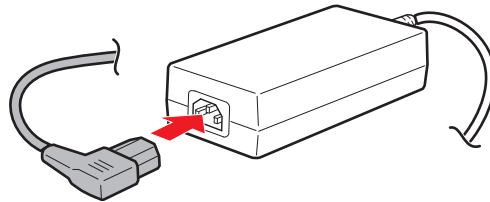

- 2 Connect the DC cable of the AC adapter to the power supply connector on the product.

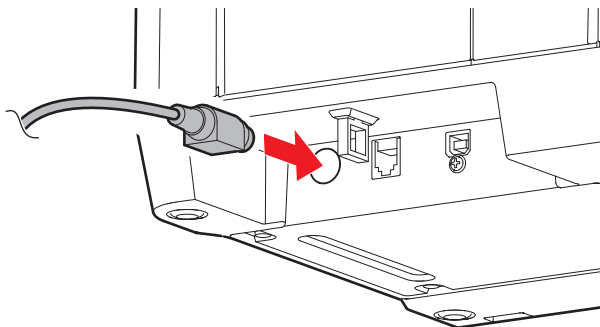

- 3 Insert the AC cable plug into a socket.

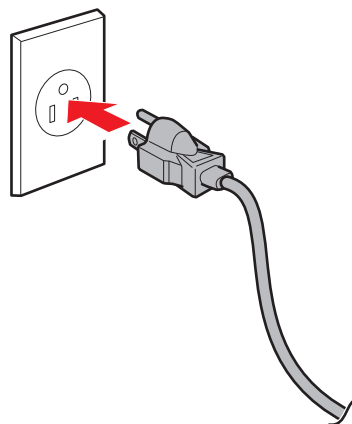

Installing and Replacing the Ink Cartridge

Follow the steps below to install the ink cartridge into the product for the first time or replace it with a new one.

CAUTION

- Do not open the ink cartridge until you are ready to install it.
- Do not touch the green IC chip on the side of the ink cartridge.
- Do not puncture the convex part of the bottom of the ink cartridge or remove the transparent film on the bottom of the ink cartridge.
- Do not remove the ink cartridge except when replacing it with a new one.
- After installing an ink cartridge, use it up within 6 months.
- Use the ink cartridge before the expiration date printed on its package and on the ink cartridge itself.
- A used cartridge may have some ink on the convex part of the bottom of the cartridge. Avoid touching that part to keep your hands clean.
- Dispose of the used ink cartridges according to the laws or regulations in your country and region.
- To transport or store this product for a long period after once using this product, make sure the ink cartridge is installed in the product.

NOTE

- When the ink cartridge is installed for the first time, the product uses ink to prepare for printing (ink charging). Make sure to use a new ink cartridge.
- Cartridge yields vary based on such usage environment and conditions.
- To insure print quality, some ink remains in the cartridge after the Ink LED comes on.
- This printer may automatically run maintenance operations at night or when the power is turned on to maintain print quality. As a result of these maintenance operations, you may need to replace the ink cartridge. In this case, replace the ink cartridge with a new one.

- 1** Turn on the product.
See "[Turning On](#)" on page 73.
- 2** Open the ink cartridge cover.
See "[Opening the Ink Cartridge Cover](#)" on page 74.

- 3 If there is a used ink cartridge, remove it by pulling up the tab on the top of the cartridge while holding the product.

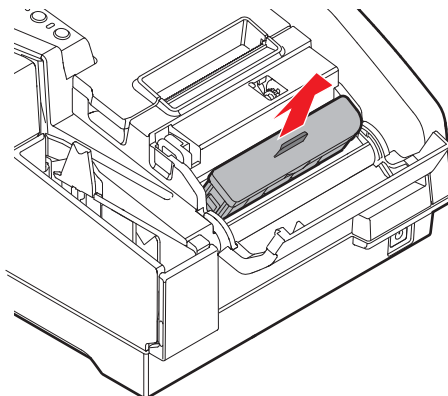

- 4 Remove a new ink cartridge from its package.
- 5 Install the ink cartridge in the correct direction, and push it until it clicks in place.

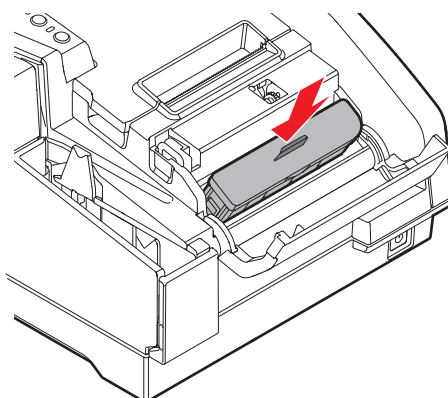

- 6 Close the ink cartridge cover.
When you first use the product, installing an ink cartridge begins charging the ink supply. Ink charging takes approximately four minutes and Power LED flashes during that time.

CAUTION

- Do not tilt the product during ink charging to avoid ink leakage.
- Be sure not to turn off the product or open the covers while the Power LED is flashing. This restarts the ink charging, which wastes ink.

- 7 Make sure the Power LED turns on after flashing.

Installing and Replacing the Roll Paper

Follow the steps below to install or replace the roll paper.

CAUTION

Use paper that meets the specification. (See "Paper Specifications" on page 39.)

- 1 Open the roll paper cover.
See "Opening the Roll Paper Cover" on page 74.
- 2 If there is a used roll paper core, remove it.
- 3 Insert the roll paper in the correct direction.

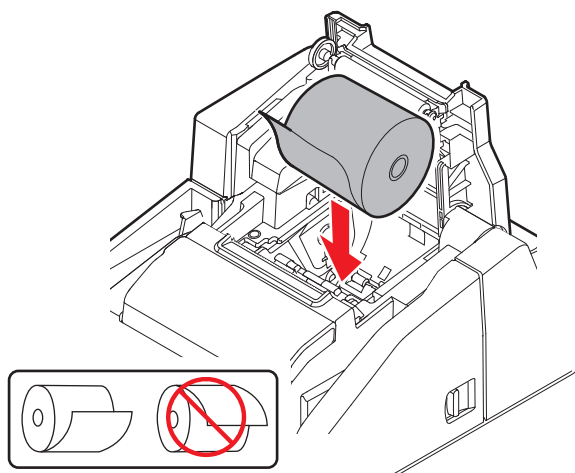

- 4 Pull out some paper, and close the roll paper cover.

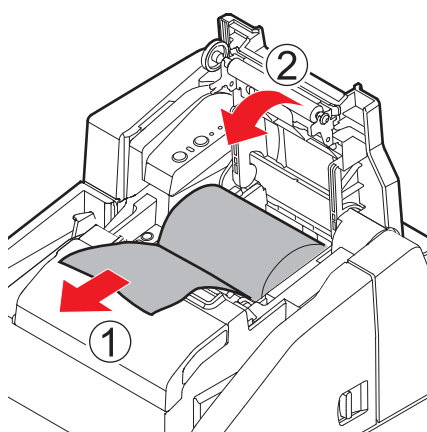

Connecting the Cash Drawer

When using a cash drawer, connect the cash drawer.

Use the cash drawer handled by EPSON or your dealer.

Connecting the Drawer Kick-out Cable



- **Specifications of drawers differ depending on makers or models. When you use a drawer other than specified, make sure its specification meets the following conditions.**

Otherwise, devices may be damaged.

- * The load, such as a drawer kick-out solenoid, must be connected between pins 4 and 2 or pins 4 and 5 of the drawer kick-out connector.
- * When the drawer open/close signal is used, a switch must be provided between drawer kick-out connector pins 3 and 6.
- * The resistance of the load, such as a drawer kick-out solenoid, must be $24\ \Omega$ or more or the input current must be 1A or less.
- * Be sure to use the 24V power output on drawer-kick out connector pin 4 for driving the equipment.
- **Use a shield cable for the drawer connector cable.**
- **Two driver transistors cannot be energized simultaneously.**
- **Leave intervals longer than 4 times the drawer driving pulse when sending it continuously.**
- **Be sure to use the printer power supply (connector pin 4) for the drawer power source.**
- **Do not insert a telephone line into the drawer kick-out connector.**
Doing so may damage the telephone line or printer.

Connect the connector of the drawer kick-out cable to the printer.

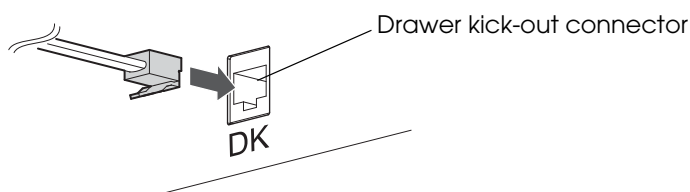

Drawer Connection Circuitry

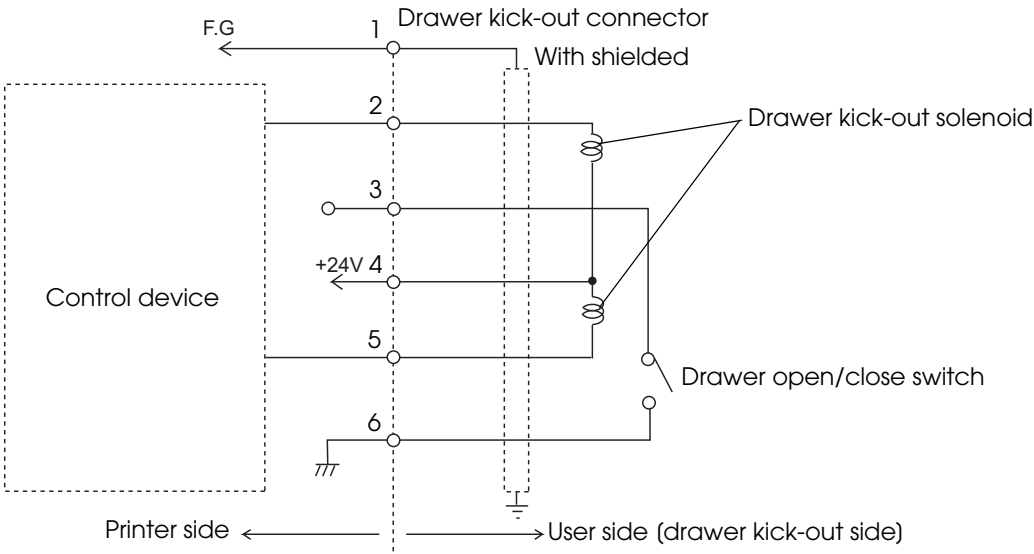

Setting the Memory Switches and R/E

With the memory switches and R/E (receipt enhancement) function, which are software settings for the printer, you can set the various functions.

For an outline of the functions, see the following section. Use the methods shown in the table below; TM-S9000 Utility or Memory Switch Setting Mode to set the memory switches and R/E functions.

Settings/Settings Methods		TM-S9000 Utility	Memory Switch Setting Mode	
Memory Switches	Power ON information	✓	✓	
	Auto line feed	✓	✓	
	Remote wake-up	✓	✓	
	Roll paper cover open during printing	✓	✓	
	Customized Values	Print density (roll paper)	✓	✓
		Cut paper when the cover is closed	✓	✓
		Roll Paper Reduction Settings	✓	✓
		Multi-tone print density	✓	✓
		Time to check ink head cleaning	✓	
		Top margin for validation	✓	
		Left margin for validation	✓	
		Top margin for cut sheet paper	✓	
		Left margin for cut sheet paper	✓	
	Time to enter power saving mode	✓		
Receipt Enhancement	Top/Bottom logo print setting	✓		
	Print top logo when paper is cut	✓		
	Print top logo when device is powered on	✓		
	Print top logo when cover is closed	✓		

NOTE

- For detailed information about the TM-S9000 Utility, see the *TM-S9000 Utility User's Manual*.
- For information about how to use the memory switch setting mode, see "[Memory Switch Setting Mode](#)" on page 72.

Functions

Power ON information

- Do not transmit (initial setting)
- Transmit

Auto line feed

- Always disabled (initial setting)
- Always enabled

Remote wake-up

- Enabled (initial setting)
- Disabled

Roll paper cover open during printing

- Auto recoverable error (initial setting)
- Recoverable error

Print density (roll paper)

Selectable from levels 1 to 13 (70% ~ 130%). (initial setting: level 7)

Depending on the paper type, it is recommended to set the print density as shown in the table below to keep the print quality.

Original paper type	Density level
AF50KS-E	4 (85%)
TF50KS-E, P220AGB-1	5 (90%)
P35023	6 (95%)
TF60KS-E, PD150R, PD160R, PD190R, KT48F20, KT55F20, F5041	7 (100%)
P30023, P31023	8 (105%)

NOTE

- When the print density setting is too dark, the printing speed tends to drop.
- When the print density setting is too dark, paper dust sticks to the print head surface, often resulting in faded print. (For how to clean the thermal head, see ["Cleaning the Thermal Head" on page 82.](#))

Cut paper when the cover is closed

- Use this function (initial setting)
- Not use this function (not recommended)

Roll Paper Reduction Settings

- Extra Upper Space Reduction: Disable (initial setting) or Enable
- Extra Lower Space Reduction: Disable (initial setting) or Enable
- Line Space Reduction Rate: Not reduced (initial setting), 25%, 50%, or 75%
- Line Feed Reduction Rate: Not reduced (initial setting), 25%, 50%, or 75%
- Barcode Height Reduction Rate: Not reduced (initial setting), 25%, 50%, or 75%

Multi-tone print density

Selectable from levels 1 to 13 (70% ~ 130%). (initial setting: level 7)

Depending on the paper type, it is recommended to set the print density.

NOTE

- When the print density setting is too dark, the printing speed tends to drop.
- When the print density setting is too dark, paper dust sticks to the print head surface, often resulting in faded print. (For instructions on how to clean the thermal head, see ["Cleaning the Thermal Head" on page 82.](#))

Time to check ink head cleaning

Time (hh:mm) is settable. (initial setting: 20:00)

Validation settings

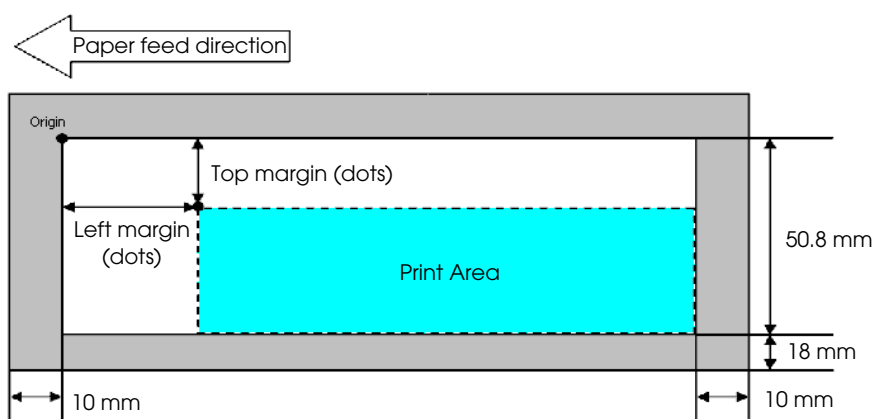

- Top margin (initial setting: 0)

- Left margin (initial setting: 0)

Slip settings

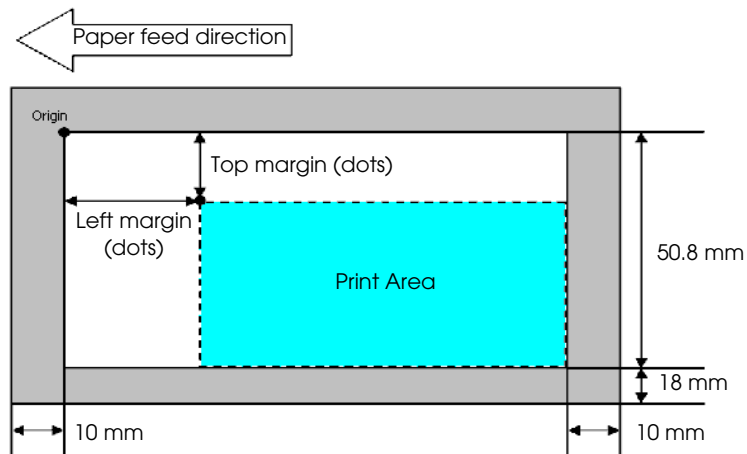

- Top margin (initial setting: 0)
- Left margin (initial setting: 0)

Time to enter power saving mode

Settable from 100ms ~ 3600s. (initial setting: 3000 [5 minutes])

Top/Bottom logo print setting

Key code

Selectable from key codes of registered logos

Alignment

- Left
- Center
- Right

Print top logo when paper is cut

- Disable
- Enable (initial setting)

Print top logo when device is powered on

- Disable (initial setting)
- Enable

Print top logo when cover is closed

- Disable
- Enable (initial setting)

Application Development Information

This chapter describes software and gives information useful for printer application development.

Software

Operating Environment

Minimum Specification

- CPU: At least a Pentium 4, 2.0 GHz or the equivalent
- Memory: At least 512 MB or above the minimum operating system requirement
- HDD: Free space of more than 30 MB (before installing the driver)
- Interface: USB 2.0 Hi-speed

Recommended Specification

- CPU: At least Intel Core 2 Duo 1.8 GHz or the equivalent
- Memory: At least 1 GB or above the minimum operating system requirement
- HDD: Free space of more than 30 MB (before installing the driver)
- Interface: USB 2.0 Hi-speed

Software for Windows

Software	Description
TM-S9000 Driver	Use this API (Application Program Interface) to fully use functions of the TM-S9000MJ, such as the scanner function, endorsement printing function, cut sheet/roll paper printing function, and to monitor the status of the TM-S9000MJ. Programming can be done in Visual C++, Basic, or other programming languages.
Printer Driver for TM-S9000	This is the standard printer driver for Windows. Printing is possible using the print function of commercially available software.
TM Virtual Port Driver for TM-S	This driver changes the interface so that a printer connected with the USB interface acts as if it is connected with the serial/parallel interface. Use this driver when you use applications that directly send control commands to printers connected with the serial/parallel interface. This driver supports the print function only. The scanner function is not available.
TM-S9000 TWAIN Wrapper	Use this software to control the TM-S9000MJ using TWAIN, the standard interface for scanners. Use it together with the TM-S9000 Driver.
TM-S9000 Java Wrapper	Use this software to control the TM-S9000MJ from Java applications. Use it together with the TM-S9000 Driver.
TM-S9000 Utility	Use this software to use or set the following functions of the TM-S9000MJ. <ul style="list-style-type: none"> * Current Settings * Operation Check * Storing Logos * Roll paper Reduction * Automatic Paper Cut * Printing Control * Device Settings * MSR Settings (only for MSR installed models) * Backup/Restore

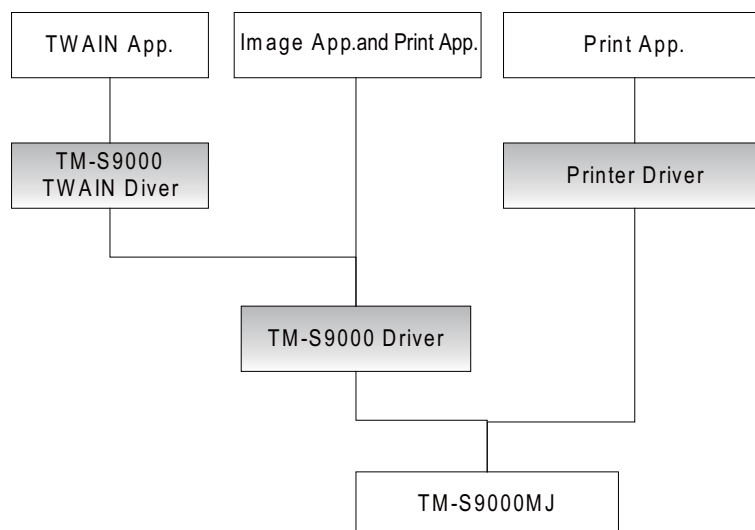

Software for Linux

Software	Description
SANE Backend	Use this software to control the TM-S9000MJ using the main scanner interface for Linux.
CUPS Driver	This is a printer driver for Linux.

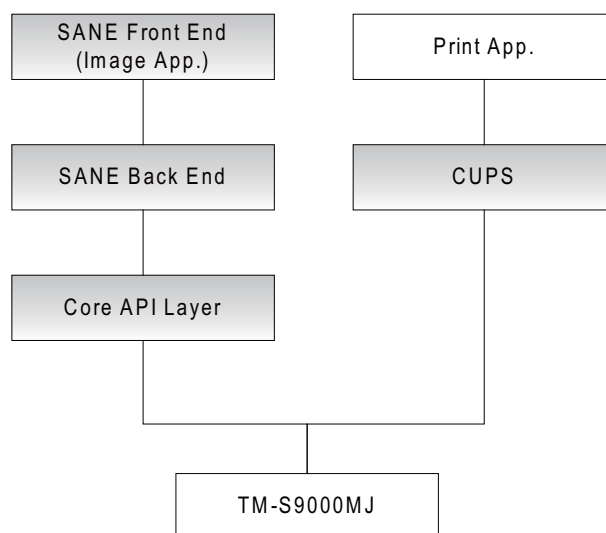

How to Get Drivers, Utilities, and Manuals

You can obtain drivers, utilities, and manuals from one of the following URLs.

For customers in North America, go to the following web site:

<http://www.epson.com/support/>

For customers in other countries, go to the following web site:

<http://download.epson-biz.com/?service=posyy>

Setting/Checking Modes

Besides the ordinary print mode, the printer has the following modes to set or check settings of the printer.

- Self-test Mode ([page 67](#))
- NV Graphics Print Mode ([page 69](#))
- Receipt Enhancement Information Print Mode ([page 71](#))
- Memory Switch Setting Mode ([page 72](#))

Self-test Mode

In the self-test mode, the printer prints the current status of the printer and resident characters as a test print on the cut sheet paper or roll paper.

You can confirm the following information with the status print.

- Firmware version
- Buffer capacity
- Handshaking operation (busy condition)
- Automatic line feed (CR command function)
- Resident character
- Power on status
- Receipt cover open
- Remote wakeup
- Nozzle check pattern (only on the cut sheet paper)
- Maintenance information
- Memory switches

Starting the test print on cut sheet paper

Follow the steps below to start a test print on the cut sheet paper.

- 1** Close all covers.
- 2** While pressing the Cleaning button, turn on the printer. (Keep pressing the Cleaning button until the Document LED starts flashing.)
The printer goes into the insertion waiting status for cut sheet paper.
- 3** Insert the cut sheet paper.
The printer starts printing the current status of the printer on the cut sheet paper.
After ejecting the cut sheet paper, the printer goes into the paper insertion waiting status again and again until printing the current status of the printer and a test print of a rolling pattern using only the built-in character set complete.
After printing the following message, the printer is initialized and returned to the normal mode.

*** completed***

Starting the status print and test print on the roll paper

Follow the steps below to start a status print and test print on the roll paper.

- 1** Install the roll paper.
- 2** Close all covers.
- 3** While pressing the Feed button, turn on the printer. (Keep pressing the Feed button until the printer starts printing.)
The printer starts printing the current status of the printer on the roll paper.
- 4** To start the test print, press the Feed button (less than 1 second).
The printer prints a rolling pattern on the roll paper, using only the built-in character set.
After printing the following message, the printer is initialized and returned to the normal mode.

*** completed***

NV Graphics Print Mode

You can confirm the following information on the cut sheet paper or roll paper by running NV graphics print mode:

- Capacity of the NV graphics
- Used amount of the NV graphics
- Unused capacity of the NV graphics
- Number of NV graphics that are registered
- Key code, number of dots in X direction, number of dots in Y direction
- NV graphics data

NOTE

For detailed information about NV graphics, see ["NV Graphics Memory" on page 29](#).

Starting the NV graphics print mode on the cut sheet paper

Follow the steps below to run this mode.

- 1** With the ink cartridge cover opened, while pressing the Cleaning button, turn on the printer. (Keep pressing the button until the Error LED lights.)
- 2** Press the Cleaning button twice.
- 3** Close the ink cartridge paper cover.
The printer starts printing the NV graphics information.
- 4** Turn the power off.
The printer returns to the normal mode.

Starting the NV graphics print mode on the roll paper

Follow the steps below to run this mode.

- 1** Install the roll paper.
- 2** With the roll paper cover opened, while pressing the Feed button, turn on the printer. (Keep pressing the button until the Error LED lights.)
- 3** Press the Feed button twice.
- 4** Close the roll paper cover.
The printer starts printing the NV graphics information.
- 5** Turn the power off.
The printer returns to the normal mode.

Receipt Enhancement Information Print Mode

You can confirm the following information on the roll paper by running the R/E information mode:

- Automatic top logo setting
- Automatic bottom logo setting
- Extended settings for automatic top/bottom logo

Starting the R/E information print mode

Follow the steps below to run this mode.

- 1** Install the roll paper.
- 2** With the roll paper cover opened, while pressing the Feed button, turn the power on. (Keep pressing the Feed button until the Error LED lights.)
- 3** Press the Feed button four times.
- 4** Close the roll paper cover.
The printer starts printing the R/E information.
- 5** Turn the power off.
The printer returns to the normal mode.

Memory Switch Setting Mode

In the memory switch setting mode, you can set the following “memory switches (customized values),” which are software switches of this printer.

- Receipt print density
- Automatic paper reduction
- Autocutting at roll paper cover close
- Automatic line feed
- Error control
- Power on notice
- Remote wake-up

NOTE

For detailed information about memory switches, see ["Setting the Memory Switches and R/E" on page 59](#).

Starting the memory switch setting mode

Follow the steps below to run this mode.

- 1** Install the roll paper.
- 2** With the roll paper cover opened, while pressing the Feed button, turn the power on. (Keep pressing the button until the Error LED lights.)
- 3** Close the roll paper cover.
The printer starts printing instructions. Follow them.
After one setting has been completed, the printer stores the setting and then starts initializing. After that, the printer returns to the normal mode.

Handling

This chapter describes basic handling of the scanner.

Turning On/Off the Product

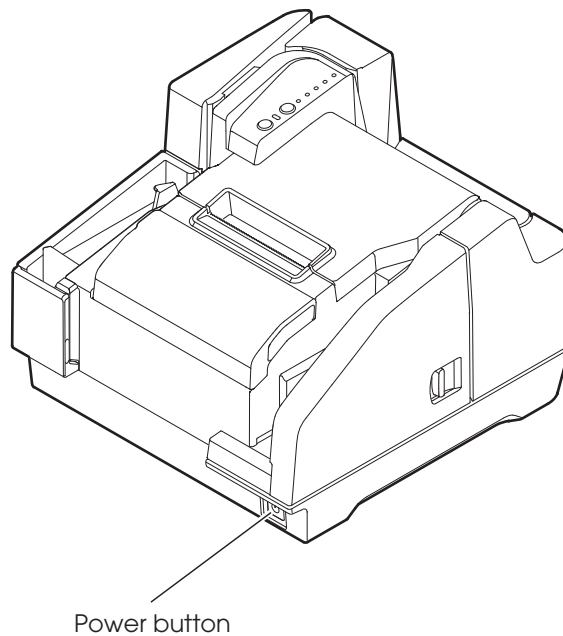

Turning On

To turn on the product, press the power button on the front side of the product.

Turning Off

CAUTION

When turning off the product, make sure the AC cable is connected to the product and a wall socket, and always use the power button.

To turn off the product, press the power button for 3 seconds or more until Power LED goes off.

Opening Covers

CAUTION

Do not open the covers while processing is in progress.

Opening the Roll Paper Cover

Put your finger under the left side of the roll paper cover and pull it up to open it.

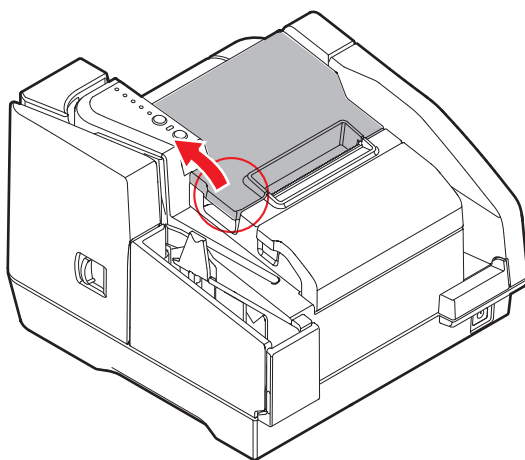
**NOTE**

If the roll paper cover will not open, see ["Roll Paper Cover Will not Open"](#) on page 88.

Opening the Ink Cartridge Cover

Put your finger under the left side of the ink cartridge cover and pull it up to open it.

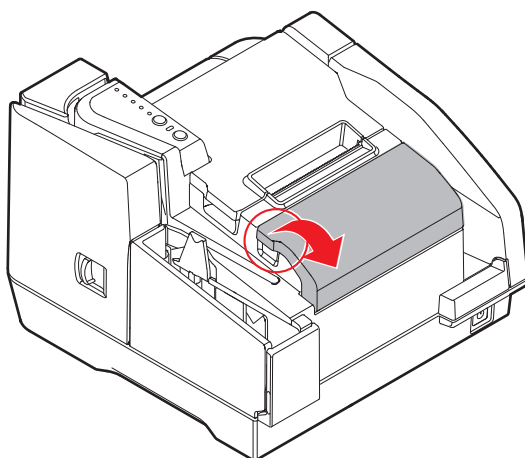

Opening the MICR Cover

Pull the MICR cover open lever and pull the MICR cover outward to open it.

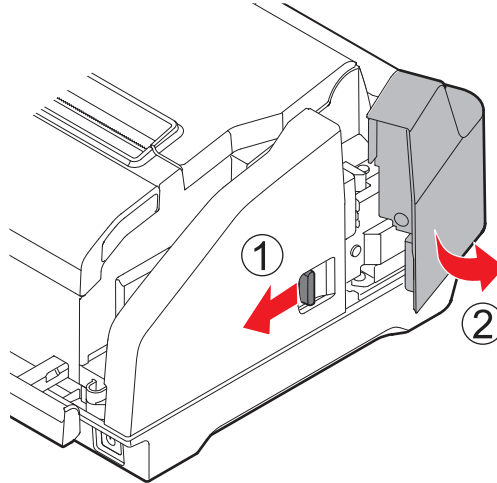

Opening the Rear Cover

Pull the rear cover open lever and pull the rear cover outward to open it.

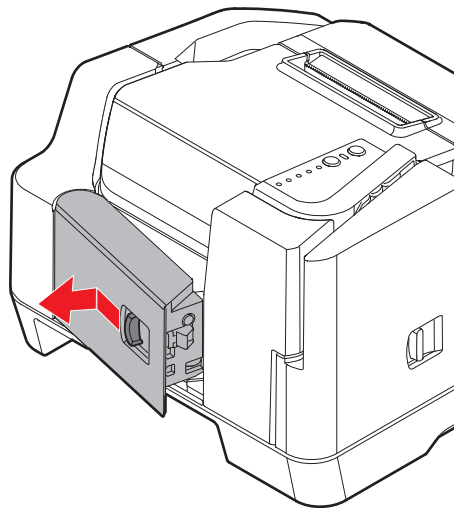

Opening the Scanner Cover

Pull the scanner cover open lever and pull the scanner cover outward to open it.

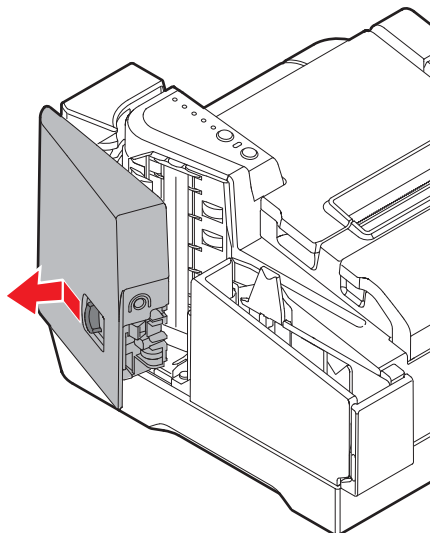

Processing Cut Sheet Paper

The TM-S9000MJ is capable of performing the following actions on cut sheet paper in a single pass.

Flow of Single Pass Processing

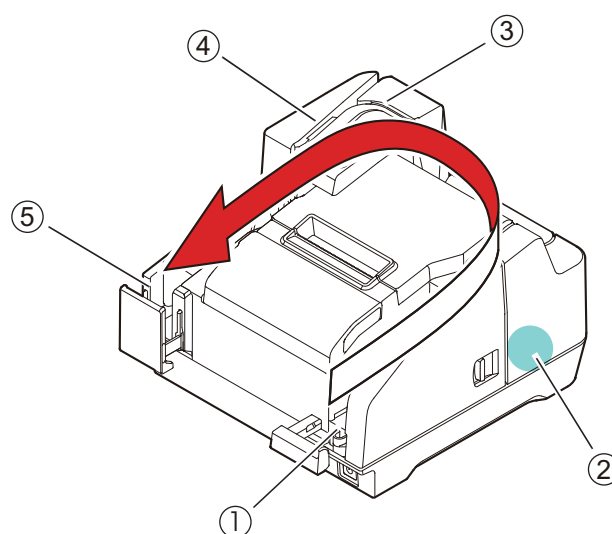

Auto sheet feeder (ASF) section feeds the cut sheet paper. (①)

MICR reader section reads magnetic ink characters on the cut sheet paper. (②)

Printer section prints on the cut sheet paper. (③)

Scanner section scans both sides of the cut sheet paper. (④)

Pocket section ejects the processed cut sheet paper. (⑤)

Important Notes on Processing Cut Sheet Paper

- Use cut sheet paper that meets the specifications. (See "[Paper Specifications](#)" on page 39.)
- Do not use copy paper or other multi-ply paper.
- Make sure that the cut sheet paper has no curl, bending (especially on the corners), warpage, or wrinkles.
- Do not use checks with paper clips, staples, adhesive tape, or other foreign materials attached.
- Be sure to let cut sheet paper go as soon as the scanner starts feeding. Otherwise, there may be a paper skew, paper jam, or MICR reading error.
- Do not open the covers while processing is in progress.

Inserting Cut Sheet Paper

You can put up to 100 sheets of cut sheet paper in the ASF to be fed automatically.

- 1 Pull out the ASF guide and the pocket guide appropriately for the size of the cut sheet paper to be set.

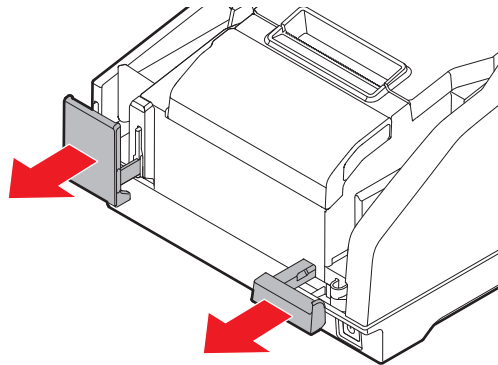

- 2 Set the cut sheet paper in the ASF with the edges aligned to the paper setting mark on the right side of the roll paper cover.

CAUTION

- Set the sheets with the face on which you want to print facing inside.
- To scan checks or read the magnetic ink characters with MICR, set the sheets with the part of the magnetic ink characters facing outside and down.
- To set multiple sheets, align them neatly on the bottom-right (insertion side) corner.
- If the sheets are inserted without being aligned, they may not be fed at all, or a paper jam or incorrect feeding of multiple sheets may result.

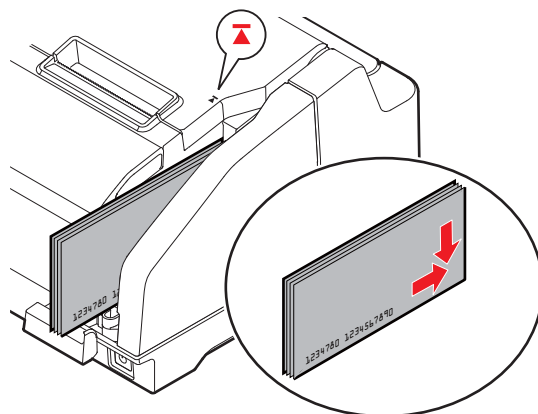

- 3 After setting the cut sheet paper, release it immediately.

CAUTION

Do not insert an ID card into the ID card insertion slot while processing cut sheet paper.

Ejecting Cut Sheet Paper

Remove the cut sheet paper when it is ejected.

CAUTION

To prevent a paper jam, do not leave more than 100 sheets in the pocket (for two-pocket models, 100 sheets in the main pocket and 50 sheets in the sub pocket) while processing cut sheet paper.

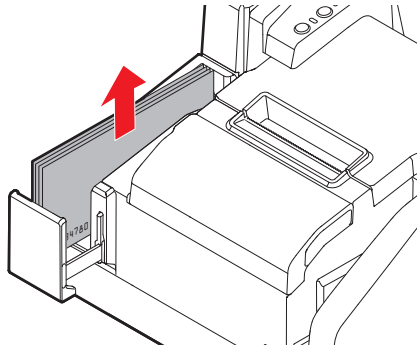
**NOTE**

For two-pocket models, paper may be ejected separately into the main pocket and the sub pocket depending on your application.

Scanning ID Cards

Follow the steps below to scan both sides of an ID card.

CAUTION

- Use an ID card that meets the specifications. (See "[Paper Specifications](#)" on page 39.)
- Make sure that the ID card is flat and does not have excessive bending, cracks, folds, or embossing.
- Do not touch the external terminal when using an IC card.

- 1** Put the ID card in the insertion slot on the right side of the pocket with its photo side facing the pocket, and slide it along the bottom of the slot.

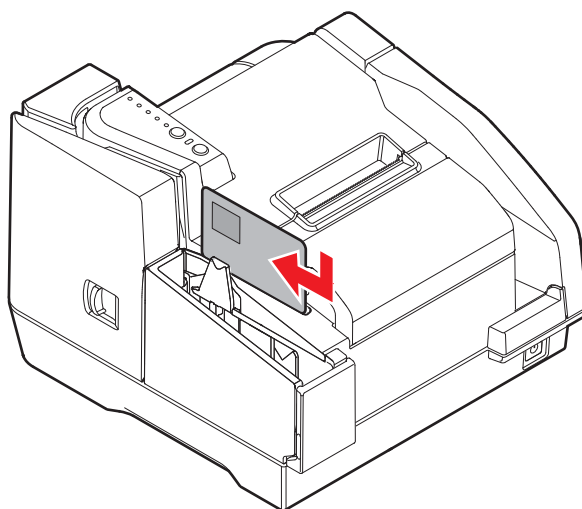

- 2** When the card starts feeding, release it immediately.

CAUTION

- When the ID card is feeding, a part of it comes out of the card carrier slit at the back of the product. Be sure not to block this slit.
- Do not touch the ID card when it is being ejected. Doing so may cause distortion and other problems with the scanned data.
- Do not open the covers while processing is in progress.

- 3** When the ID card is ejected and the ID Card LED flashes, remove the ID card from the slot.

Reading Magnetic Stripe Cards

If your product has a MSR unit, you can read the magnetic stripe on the card.

CAUTION

Use a magnetic stripe card that meets the specification. (See "[MSR \(Factory Option\)](#)" on [page 38](#).)

To read the magnetic stripe card, check the insertion direction with the arrow on the card, and swipe it through the slit downward or upward with the magnetic stripe on the card facing inside and down.

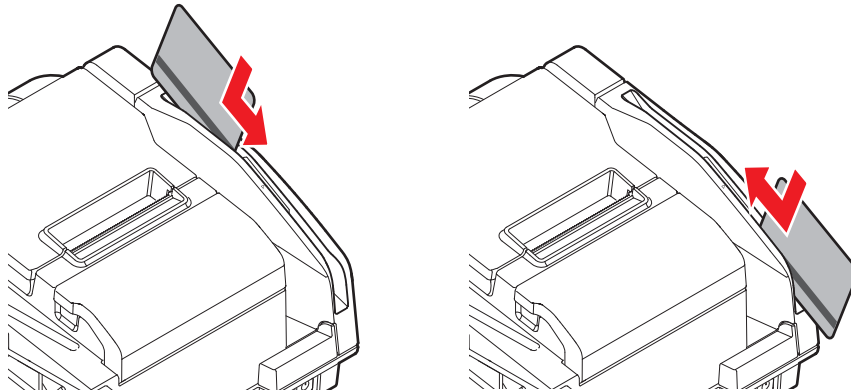

The buzzer beeps once when reading succeeds and beeps three times when it fails.

Cleaning

Cleaning the Thermal Head

Epson recommends cleaning the thermal head periodically (generally every 3 months) to maintain thermal printing quality.



- The thermal head can be very hot after printing. Be careful not to touch it, and let it cool before you clean it.
- Do not damage the thermal head by touching it with your fingers or any hard object.

Turn off the product, open the roll paper cover, and clean the thermal elements of the thermal head with a cotton swab moistened with an alcohol solvent (ethanol or IPA).

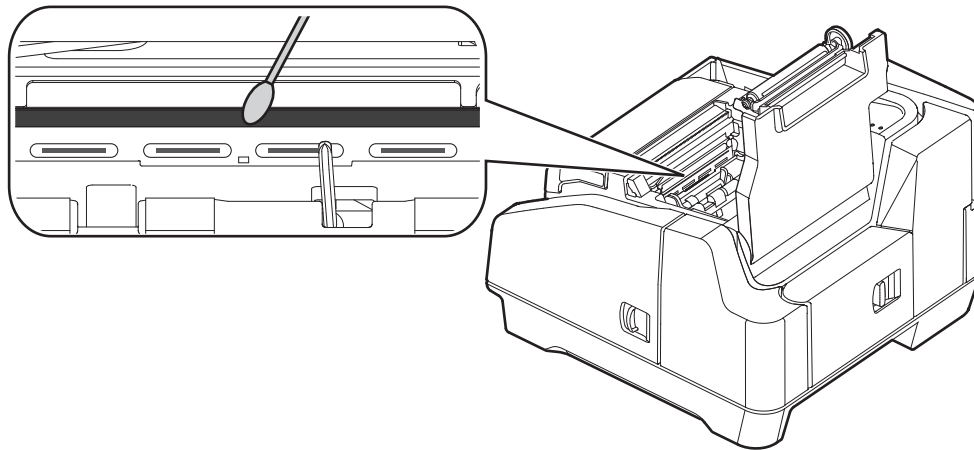

Cleaning the Ink-Jet Head

When printing on cut sheet paper becomes faint or uneven although the Ink LED is not on or flashing, the ink-jet head may need to be cleaned.



The cleaning process uses some ink. Do not run cleaning when it is unnecessary.

To start the ink-jet head cleaning, press the cleaning button on the control panel for 3 seconds or more. During the cleaning, Power LED flashes.

When Power LED comes on after flashing, the ink-jet head cleaning is completed.

Cleaning the MICR Head

When the MICR head becomes dirty, the product cannot read the magnetic ink characters normally.

Clean the MICR head every 6 months or every 100,000 passes by setting the following cleaning sheet in the same way as cut sheet paper. (See ["Inserting Cut Sheet Paper" on page 78.](#))

- KIC Team, Inc. "Waffletechnology[®] cleaning card" (CS1B15WS)
- KIC Team, Inc. "Epson Check Scanner Cleaning Kit" (Model: KWEPS-KCS2)

Use a cleaning sheet only one time; then discard it.

NOTE

- It is recommended to clean the MICR head once per week or once every 2,000 sheets for good reading results.
- It is recommended to clean the scanner after cleaning the MICR head.

Cleaning the Scanner

If the glass of the scanner gets soiled from ink or paper dust, the quality of scanned data may deteriorate. Clean the glass every 6 months or every 100,000 passes by following the steps below.



- **Do not use synthetic detergent, benzine, water, or other liquid for cleaning.** Doing so may result in a stain.
- **Never apply any liquid directly to the glass of the scanner.**

- 1 Open the scanner cover.
See ["Opening the Scanner Cover" on page 76.](#)

- 2 Lightly wipe 2 parts of glass areas shown in the picture below with a soft, dry cloth.

When the glass of the scanner is smeared with oil, grease or other unremovable substance, wipe it with a cloth lightly dipped in alcohol. However, never apply any liquid directly to the glass of the scanner.

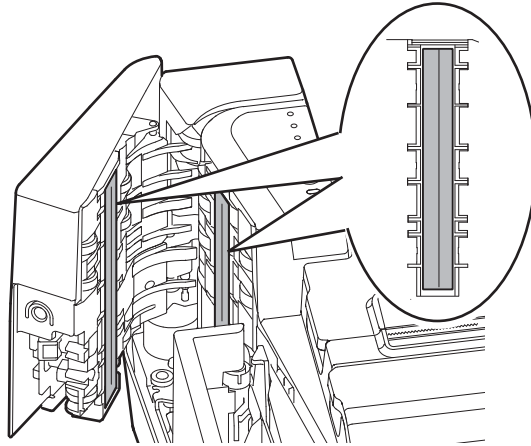

- 3 Close the scanner cover firmly until it clicks in place.

NOTE

It is recommended to clean the scanner once per week or once every 2,000 sheets for good reading results.

Cleaning the Product Case

Be sure to turn off the product, and wipe the dirt off the product case with a dry cloth or a damp cloth.



Never clean the product with alcohol, benzine, thinner, or other such solvents.
Doing so may damage or break the parts made of plastic and rubber.

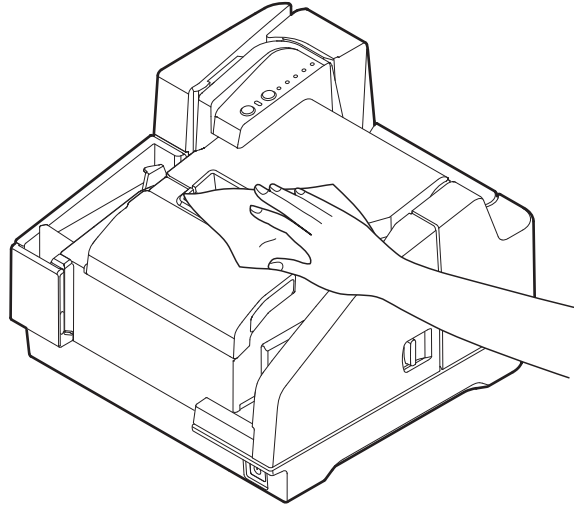

Troubleshooting

Error LED Is On or Flashing

See ["Error Status" on page 26](#).

Paper or ID Card Is Jammed

When the roll paper is jammed

Follow the steps below to remove jammed roll paper.



Do not touch the thermal head, because it can be very hot after printing. Let it cool before you remove the jammed paper.

- 1** Turn off the product.
See ["Turning Off" on page 73](#).
- 2** Open the roll paper cover.
See ["Opening the Roll Paper Cover" on page 74](#).

NOTE

If the roll paper cover will not open, see ["Roll Paper Cover Will not Open" on page 88](#).

- 3** Remove the jammed paper.
- 4** Close the roll paper cover.

When cut sheet paper is jammed

Open the MICR cover, rear cover, or scanner cover to remove the jammed paper in the paper path.

See ["Opening the MICR Cover" on page 75](#), ["Opening the Rear Cover" on page 75](#), and ["Opening the Scanner Cover" on page 76](#).

When an ID card is jammed

Open the scanner cover to remove the jammed ID card.

See ["Opening the Scanner Cover" on page 76](#).

Printout Is Faint

Printing on roll paper is faint

The thermal head may be dirty.

See ["Cleaning the Thermal Head" on page 82](#) to clean the thermal head.

Printing on cut sheet paper is faint

The ink-jet head may be dirty.

See ["Cleaning the Ink-Jet Head" on page 82](#) to clean the ink-jet head.

Reading/Scanning Is not Normal

Magnetic ink character cannot be read normally

The MICR head may be dirty.

See ["Cleaning the MICR Head" on page 83](#) to clean the MICR head.

Scanned data is not normal

The scanner glass may be dirty.

See ["Cleaning the Scanner" on page 83](#) to clean the scanner glass.

Roll Paper Cover Will not Open

When the roll paper cover will not open, the autocutter blade is locked.

Follow the steps below to return the autocutter blade to the correct position.

- 1** Turn off the product.
See "[Turning Off](#)" on page 73.
- 2** Open the ink cartridge cover.
See "[Opening the Ink Cartridge Cover](#)" on page 74.
- 3** Turn the knob of the autocutter blade in the direction of the arrow until you see a pin in the opening of the frame.

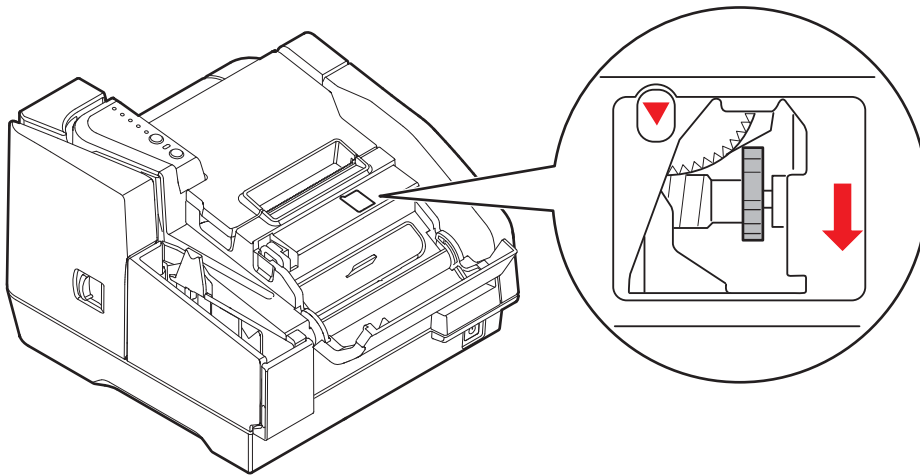

- 4** Close the ink cartridge cover.

Preparing for Transport

Follow the steps below to transport the product.

CAUTION

Keep the product upright and horizontal during transportation.

Install the transportation cartridge

If transporting a product for which the initial ink filling has been done, install the transportation cartridge and transport it. Failure to do so may cause ink leaks.

Transportation cartridge: TRANSPORTATION CARTRIDGE, SJIC18, UNIT

- 1** Turn on the product.
See ["Turning On" on page 73](#).
- 2** Open the ink cartridge cover.
See ["Opening the Ink Cartridge Cover" on page 74](#).
- 3** Remove it by pulling up the tab on the top of the cartridge while holding the product.
- 4** Install the transportation ink cartridge in the correct direction, and push it until it clicks in place.
- 5** Close the ink cartridge cover.

Pack the scanner

- 1** Turn off the product.
See ["Turning Off" on page 73](#).
- 2** Confirm that  Power LED is off.
- 3** Remove the power supply connector.
- 4** Store the ASF guide and the pocket guide inside the scanner.
- 5** Pack the scanner upright.

Appendix

Specifications of USB Interface

USB Interface (Type B)

Outline

- High-speed transmission at 480 Mbps [bps: bits per second]
- Plug & Play, Hot Insertion & Removal

USB transmission specifications

Overall specifications	According to USB 2.0 specifications
Transmission speed	USB High-Speed (480 Mbps) USB Full-Speed (12 Mbps)
Transmission method	USB bulk/USB interrupt transmission
Power supply specifications	USB self power supply function
Current consumed by USB bus	0 mA

Optional USB Interface (Type A)

This connector is for two-port USB-HUB connector.

USB transmission specifications

Overall specifications	According to USB 2.0 specifications
Transmission speed	USB High-Speed (480 Mbps) USB Full-Speed (12 Mbps)
Power supply specifications	Bus Powered
Current consumed by USB bus	Maximum 100 mA for each port

Character Code Tables

CAUTION

- The character code tables show only character configurations. They do not show the actual print pattern.
- “SP” in the table shows a space.

Common to All Pages

When the international character set (See "[International Character Sets](#)" on page 104.) is USA:

HEX	0	1	2	3	4	5	6	7
0	NUL 00	DLE 16	SP 32	0 48	@ 64	P 80	` 96	p 112
1		XON 17	! 33	1 49	A 65	Q 81	a 97	q 113
2			" 34	2 50	B 66	R 82	b 98	r 114
3		XOFF 19	# 35	3 51	C 67	S 83	c 99	s 115
4	EOT 04	DC4 20	\$ 36	4 52	D 68	T 84	d 100	t 116
5	ENQ 05	NAK 21	% 37	5 53	E 69	U 85	e 101	u 117
6	ACK 06		& 38	6 54	F 70	V 86	f 102	v 118
7			' 39	7 55	G 71	W 87	g 103	w 119
8		CAN 24	(40	8 56	H 72	X 88	h 104	x 120
9	HT 09) 41	9 57	I 73	Y 89	i 105	y 121
A	LF 10		* 42	: 58	J 74	Z 90	j 106	z 122
B		ESC 27	+ 43	; 59	K 75	[91	k 107	{ 123
C	FF 12	FS 28	, 44	< 60	L 76	¥ 92	l 108	 124
D	CR 13	GS 29	- 45	= 61	M 77] 93	m 109	} 125
E		RS 30	. 46	> 62	N 78	^ 94	n 110	~ 126
F			/ 47	? 63	O 79	_ 95	o 111	SP 127









Page 0 (PC437: USA, Standard Europe)

HEX	8	9	A	B	C	D	E	F
0	Ç 128	É 144	á 160	☐ 176	L 192	⌌ 208	α 224	≡ 240
1	ü 129	æ 145	í 161	☐ 177	⊥ 193	⌌ 209	β 225	± 241
2	é 130	Æ 146	ó 162	☐ 178	⊥ 194	⌌ 210	Γ 226	≥ 242
3	â 131	ô 147	ú 163	 179	⊥ 195	⌌ 211	π 227	≤ 243
4	ä 132	ö 148	ñ 164	⊥ 180	— 196	⌌ 212	Σ 228	∫ 244
5	à 133	ò 149	Ñ 165	⊥ 181	⊥ 197	F 213	σ 229	∫ 245
6	å 134	û 150	ä 166	⌌ 182	⌌ 198	⌌ 214	μ 230	÷ 246
7	ç 135	ù 151	º 167	⌌ 183	⌌ 199	⌌ 215	τ 231	≈ 247
8	ê 136	ÿ 152	¿ 168	⌌ 184	⌌ 200	⌌ 216	Φ 232	° 248
9	ë 137	Ö 153	Г 169	⌌ 185	⌌ 201	⌌ 217	Θ 233	• 249
A	è 138	Ü 154	Г 170	⌌ 186	⌌ 202	⌌ 218	Ω 234	• 250
B	ï 139	ç 155	½ 171	⌌ 187	⌌ 203	■ 219	δ 235	√ 251
C	î 140	£ 156	¼ 172	⌌ 188	⌌ 204	■ 220	∞ 236	ⁿ 252
D	ì 141	¥ 157	ı 173	⌌ 189	= 205	■ 221	Φ 237	² 253
E	Ä 142	Pt 158	« 174	⌌ 190	⌌ 206	■ 222	ε 238	■ 254
F	Å 143	f 159	» 175	⌌ 191	⌌ 207	■ 223	∩ 239	SP 255

HEX	8	9	A	B	C	D	E	F
0	▬ 128	┘ 144	SP 160	▬ 176	々 192	≡ 208	= 224	× 240
1	■ 129	┘ 145	。 161	ア 177	チ 193	ム 209	フ 225	円 241
2	■ 130	┘ 146	「 162	イ 178	ツ 194	メ 210	≠ 226	年 242
3	■ 131	┘ 147	」 163	ウ 179	テ 195	モ 211	≡ 227	月 243
4	■ 132	▬ 148	、 164	エ 180	ト 196	ヤ 212	▲ 228	日 244
5	■ 133	▬ 149	・ 165	オ 181	ナ 197	ユ 213	▶ 229	時 245
6	■ 134	┘ 150	ヲ 166	カ 182	ニ 198	ヨ 214	▼ 230	分 246
7	■ 135	┘ 151	ア 167	キ 183	ヌ 199	ラ 215	▶ 231	秒 247
8	┘ 136	「 152	イ 168	ク 184	ネ 200	リ 216	♠ 232	千 248
9	┘ 137	┘ 153	ウ 169	ケ 185	ノ 201	ル 217	♥ 233	市 249
A	┘ 138	┘ 154	エ 170	コ 186	ハ 202	レ 218	♦ 234	区 250
B	┘ 139	┘ 155	オ 171	サ 187	ヒ 203	ロ 219	♣ 235	町 251
C	┘ 140	┘ 156	ヤ 172	シ 188	フ 204	ワ 220	● 236	村 252
D	┘ 141	┘ 157	ユ 173	ス 189	ヘ 205	ン 221	○ 237	人 253
E	┘ 142	┘ 158	ヨ 174	セ 190	ホ 206	ッ 222	/ 238	■ 254
F	┘ 143	┘ 159	ツ 175	ソ 191	マ 207	。 223	\ 239	SP 255



Page 2 (PC850: Multilingual)

HEX	8	9	A	B	C	D	E	F
0	Ç 128	É 144	á 160	☐ 176	Ł 192	ð 208	Ó 224	- 240
1	ü 129	æ 145	í 161	☐ 177	⊥ 193	Ð 209	β 225	± 241
2	é 130	Æ 146	ó 162	☐ 178	⊥ 194	Ê 210	Ô 226	= 242
3	â 131	ô 147	ú 163	 179	† 195	Ë 211	Ò 227	¾ 243
4	ä 132	ö 148	ñ 164	‡ 180	— 196	È 212	õ 228	¶ 244
5	à 133	ò 149	Ñ 165	Á 181	† 197	ı 213	Õ 229	§ 245
6	å 134	û 150	ä 166	Â 182	ã 198	Í 214	μ 230	÷ 246
7	ç 135	ù 151	œ 167	À 183	Ã 199	Î 215	þ 231	˘ 247
8	ê 136	ÿ 152	¿ 168	© 184	ℒ 200	Ï 216	ƒ 232	° 248
9	ë 137	Ö 153	® 169	‡ 185	ℓ 201	Ɔ 217	Ú 233	¨ 249
A	è 138	Ü 154	¬ 170	 186	⊥ 202	ƒ 218	Û 234	· 250
B	ï 139	ø 155	½ 171	¶ 187	⊥ 203	■ 219	Ù 235	¹ 251
C	î 140	£ 156	¼ 172	¶ 188	⊥ 204	■ 220	Ý 236	³ 252
D	ì 141	Ø 157	ı 173	¢ 189	= 205	ı 221	Ý 237	² 253
E	Ä 142	× 158	« 174	¥ 190	⊥ 206	Ï 222	— 238	■ 254
F	Å 143	f 159	» 175	‡ 191	α 207	■ 223	' 239	SP 255









HEX	8	9	A	B	C	D	E	F
0	Ç 128	É 144	á 160	 176	Ł 192	⋮ 208	α 224	≡ 240
1	ü 129	À 145	í 161	 177	⊥ 193	⸮ 209	β 225	± 241
2	é 130	È 146	ó 162	 178	⸮ 194	π 210	Γ 226	≥ 242
3	â 131	ô 147	ú 163	 179	⸮ 195	ℒ 211	π 227	≤ 243
4	ã 132	õ 148	ñ 164	⸮ 180	— 196	ℓ 212	Σ 228	∫ 244
5	à 133	ò 149	Ñ 165	⸮ 181	† 197	ƒ 213	σ 229	∫ 245
6	Á 134	Ú 150	ª 166	⸮ 182	ƒ 198	π 214	μ 230	÷ 246
7	ç 135	ù 151	º 167	π 183	⸮ 199	⸮ 215	τ 231	≈ 247
8	ê 136	Ì 152	¿ 168	⸮ 184	ℒ 200	⸮ 216	Φ 232	° 248
9	Ê 137	Õ 153	Ò 169	⸮ 185	ƒ 201	⸮ 217	Θ 233	• 249
A	è 138	Ü 154	¬ 170	⸮ 186	⸮ 202	ƒ 218	Ω 234	· 250
B	Í 139	ç 155	½ 171	⸮ 187	⸮ 203	 219	ð 235	√ 251
C	Ô 140	£ 156	¼ 172	⸮ 188	⸮ 204	 220	∞ 236	ⁿ 252
D	ì 141	Ù 157	ì 173	⸮ 189	= 205	 221	Φ 237	² 253
E	Ã 142	Pt 158	« 174	⸮ 190	⸮ 206	 222	ε 238	■ 254
F	Â 143	Ó 159	» 175	⸮ 191	⸮ 207	 223	∩ 239	SP 255

Page 4 (PC863: Canadian-French)

HEX	8	9	A	B	C	D	E	F
0	Ç 128	É 144	ı 160	☐ 176	L 192	⌌ 208	α 224	≡ 240
1	ü 129	È 145	´ 161	☐ 177	⊥ 193	⌌ 209	β 225	± 241
2	é 130	Ê 146	ó 162	☐ 178	⊤ 194	⌌ 210	Γ 226	≥ 242
3	â 131	ô 147	ú 163	 179	⊥ 195	⌌ 211	π 227	≤ 243
4	Â 132	Ë 148	¨ 164	⊥ 180	— 196	⌌ 212	Σ 228	∫ 244
5	à 133	Ï 149	˙ 165	⊥ 181	⊥ 197	F 213	σ 229	∫ 245
6	¶ 134	û 150	³ 166	⌌ 182	⊥ 198	π 214	μ 230	÷ 246
7	ç 135	ù 151	— 167	⌌ 183	⌌ 199	⌌ 215	τ 231	≈ 247
8	ê 136	α 152	Î 168	⊥ 184	⌌ 200	⊥ 216	Φ 232	° 248
9	ë 137	Ô 153	⌌ 169	⌌ 185	⌌ 201	⌌ 217	Θ 233	• 249
A	è 138	Û 154	¬ 170	⌌ 186	⌌ 202	⌌ 218	Ω 234	· 250
B	ï 139	ϕ 155	½ 171	⌌ 187	⌌ 203	■ 219	δ 235	√ 251
C	î 140	£ 156	¼ 172	⌌ 188	⌌ 204	■ 220	∞ 236	ⁿ 252
D	= 141	Û 157	¾ 173	⌌ 189	= 205	■ 221	Φ 237	² 253
E	À 142	Û 158	« 174	⌌ 190	⌌ 206	■ 222	ε 238	■ 254
F	§ 143	f 159	» 175	⌌ 191	⌌ 207	■ 223	∩ 239	SP 255

HEX	8	9	A	B	C	D	E	F
0	Ç 128	É 144	á 160	 176	L 192	⌌ 208	α 224	≡ 240
1	ü 129	æ 145	í 161	 177	⊥ 193	⌌ 209	β 225	± 241
2	é 130	Æ 146	ó 162	 178	⊥ 194	⌌ 210	Γ 226	≥ 242
3	â 131	ô 147	ú 163	 179	⊥ 195	⌌ 211	π 227	≤ 243
4	ä 132	ö 148	ñ 164	⊥ 180	— 196	⌌ 212	Σ 228	∫ 244
5	à 133	ò 149	Ñ 165	⊥ 181	⊥ 197	⌌ 213	σ 229	∫ 245
6	å 134	û 150	ä 166	⌌ 182	⌌ 198	⌌ 214	μ 230	÷ 246
7	ç 135	ù 151	º 167	⌌ 183	⌌ 199	⌌ 215	τ 231	≈ 247
8	ê 136	ÿ 152	¿ 168	⌌ 184	⌌ 200	⌌ 216	Φ 232	° 248
9	ë 137	Ö 153	Г 169	⌌ 185	Г 201	⌌ 217	Θ 233	• 249
A	è 138	Ü 154	Г 170	⌌ 186	⌌ 202	Г 218	Ω 234	• 250
B	ï 139	ø 155	½ 171	⌌ 187	⌌ 203	■ 219	δ 235	√ 251
C	î 140	£ 156	¼ 172	⌌ 188	⌌ 204	■ 220	∞ 236	ⁿ 252
D	ì 141	Ø 157	ì 173	⌌ 189	= 205	■ 221	Φ 237	² 253
E	Ä 142	Pt 158	« 174	⌌ 190	⌌ 206	■ 222	ε 238	■ 254
F	Å 143	f 159	α 175	⌌ 191	⌌ 207	■ 223	∩ 239	SP 255

HEX	8	9	A	B	C	D	E	F
0	€ 128	SP 144	SP 160	° 176	À 192	Đ 208	à 224	đ 240
1	SP 129	‘ 145	ı 161	± 177	Á 193	Ñ 209	á 225	ñ 241
2	, 130	’ 146	ç 162	² 178	Â 194	Ò 210	â 226	ò 242
3	f 131	“ 147	£ 163	³ 179	Ã 195	Ó 211	ã 227	ó 243
4	” 132	” 148	¤ 164	´ 180	Ä 196	Ô 212	ä 228	ô 244
5	... 133	• 149	¥ 165	µ 181	Å 197	Õ 213	å 229	õ 245
6	† 134	– 150	ı 166	¶ 182	Æ 198	Ö 214	æ 230	ö 246
7	‡ 135	— 151	§ 167	· 183	Ç 199	× 215	ç 231	÷ 247
8	^ 136	~ 152	¨ 168	¸ 184	È 200	Ø 216	è 232	ø 248
9	‰ 137	™ 153	© 169	¹ 185	É 201	Ù 217	é 233	ù 249
A	Š 138	š 154	ª 170	º 186	Ê 202	Ú 218	ê 234	ú 250
B	‹ 139	› 155	« 171	» 187	Ë 203	Û 219	ë 235	û 251
C	Œ 140	œ 156	¬ 172	¼ 188	Ì 204	Ü 220	ì 236	ü 252
D	SP 141	SP 157	- 173	½ 189	Í 205	Ý 221	í 237	ý 253
E	Ž 142	ž 158	® 174	¾ 190	Î 206	Þ 222	î 238	þ 254
F	SP 143	ÿ 159	– 175	¿ 191	Ï 207	ß 223	ï 239	ÿ 255

HEX	8	9	A	B	C	D	E	F
0	А 128	Р 144	а 160	 176	Л 192	л 208	р 224	ё 240
1	Б 129	С 145	б 161	 177	Л 193	л 209	с 225	ё 241
2	В 130	Т 146	в 162	 178	Т 194	т 210	т 226	ё 242
3	Г 131	У 147	г 163	 179	т 195	л 211	у 227	ё 243
4	Д 132	Ф 148	д 164	† 180	— 196	л 212	ф 228	ï 244
5	Е 133	Х 149	е 165	† 181	† 197	ф 213	х 229	ï 245
6	Ж 134	Ц 150	ж 166	 182	† 198	г 214	ц 230	ÿ 246
7	З 135	Ч 151	з 167	 183	 199	 215	ч 231	ÿ 247
8	И 136	Ш 152	и 168	† 184	л 200	† 216	ш 232	° 248
9	Й 137	Щ 153	й 169	 185	г 201	┘ 217	щ 233	• 249
A	К 138	Ъ 154	к 170	 186	л 202	г 218	ъ 234	· 250
B	Л 139	Ы 155	л 171	† 187	л 203	 219	ы 235	√ 251
C	М 140	Ь 156	м 172	л 188	л 204	 220	ь 236	№ 252
D	Н 141	Э 157	н 173	л 189	= 205	 221	э 237	¤ 253
E	О 142	Ю 158	о 174	† 190	 206	 222	ю 238	■ 254
F	П 143	Я 159	п 175	† 191	л 207	 223	я 239	SP 255

Page 18 (PC852: Latin2)

HEX	8	9	A	B	C	D	E	F
0	Ç 128	É 144	á 160	☐ 176	L 192	đ 208	Ó 224	- 240
1	ü 129	Í 145	í 161	☐ 177	⊥ 193	Đ 209	β 225	“ 241
2	é 130	Í 146	ó 162	☐ 178	⊥ 194	Ď 210	Ô 226	˘ 242
3	â 131	ô 147	ú 163	 179	† 195	Ě 211	Ń 227	˘ 243
4	ä 132	ö 148	Ą 164	† 180	- 196	ď 212	ń 228	˘ 244
5	û 133	Ĺ 149	ą 165	Á 181	† 197	Ň 213	ň 229	§ 245
6	ć 134	ĭ 150	ž 166	Â 182	Ă 198	Í 214	Š 230	÷ 246
7	ç 135	Ś 151	ż 167	Ě 183	ă 199	Î 215	š 231	˘ 247
8	ł 136	ś 152	Ę 168	Ş 184	Ł 200	ě 216	Ŕ 232	° 248
9	ë 137	Ö 153	ę 169	‡ 185	Ɔ 201	Ɔ 217	Ú 233	“ 249
A	Ő 138	Ü 154	SP 170	 186	⊥ 202	Ɔ 218	ŕ 234	• 250
B	ő 139	Ť 155	ž 171	‡ 187	⊥ 203	■ 219	Ů 235	ů 251
C	î 140	ĭ 156	Č 172	‡ 188	‡ 204	■ 220	ý 236	Ř 252
D	Ž 141	Ł 157	ş 173	Ž 189	= 205	‡ 221	Ý 237	ř 253
E	Ä 142	× 158	« 174	ž 190	‡ 206	Ů 222	ţ 238	■ 254
F	Ć 143	č 159	» 175	‡ 191	α 207	■ 223	’ 239	SP 255

HEX	8	9	A	B	C	D	E	F
0	Ç 128	É 144	á 160	☐ 176	Ł 192	ð 208	Ó 224	- 240
1	ü 129	æ 145	í 161	☐ 177	⊥ 193	Ð 209	β 225	± 241
2	é 130	Æ 146	ó 162	☐ 178	⊥ 194	Ê 210	Ô 226	= 242
3	â 131	ô 147	ú 163	 179	† 195	Ë 211	Ò 227	¾ 243
4	ä 132	ö 148	ñ 164	‡ 180	- 196	È 212	õ 228	¶ 244
5	à 133	ò 149	Ñ 165	Á 181	† 197	€ 213	Õ 229	§ 245
6	å 134	û 150	ä 166	Â 182	ã 198	Í 214	μ 230	÷ 246
7	ç 135	ù 151	º 167	À 183	Ã 199	Î 215	þ 231	˘ 247
8	ê 136	ÿ 152	¿ 168	© 184	ℒ 200	Ï 216	ƒ 232	° 248
9	ë 137	Ö 153	® 169	‡ 185	℞ 201	Ɔ 217	Ú 233	¨ 249
A	è 138	Ü 154	¬ 170	 186	⊥ 202	ƒ 218	Û 234	· 250
B	ï 139	ø 155	½ 171	¶ 187	π 203	■ 219	Ù 235	¹ 251
C	î 140	£ 156	¼ 172	¶ 188	 204	■ 220	Ý 236	³ 252
D	ì 141	Ø 157	ì 173	¢ 189	= 205	ì 221	Ý 237	² 253
E	Ä 142	× 158	« 174	¥ 190	 206	Ï 222	- 238	■ 254
F	Å 143	f 159	» 175	‡ 191	α 207	■ 223	' 239	SP 255

Page 255 (User-Defined Page)

HEX	8	9	A	B	C	D	E	F
0	SP 128	SP 144	SP 160	SP 176	SP 192	SP 208	SP 224	SP 240
1	SP 129	SP 145	SP 161	SP 177	SP 193	SP 209	SP 225	SP 241
2	SP 130	SP 146	SP 162	SP 178	SP 194	SP 210	SP 226	SP 242
3	SP 131	SP 147	SP 163	SP 179	SP 195	SP 211	SP 227	SP 243
4	SP 132	SP 148	SP 164	SP 180	SP 196	SP 212	SP 228	SP 244
5	SP 133	SP 149	SP 165	SP 181	SP 197	SP 213	SP 229	SP 245
6	SP 134	SP 150	SP 166	SP 182	SP 198	SP 214	SP 230	SP 246
7	SP 135	SP 151	SP 167	SP 183	SP 199	SP 215	SP 231	SP 247
8	SP 136	SP 152	SP 168	SP 184	SP 200	SP 216	SP 232	SP 248
9	SP 137	SP 153	SP 169	SP 185	SP 201	SP 217	SP 233	SP 249
A	SP 138	SP 154	SP 170	SP 186	SP 202	SP 218	SP 234	SP 250
B	SP 139	SP 155	SP 171	SP 187	SP 203	SP 219	SP 235	SP 251
C	SP 140	SP 156	SP 172	SP 188	SP 204	SP 220	SP 236	SP 252
D	SP 141	SP 157	SP 173	SP 189	SP 205	SP 221	SP 237	SP 253
E	SP 142	SP 158	SP 174	SP 190	SP 206	SP 222	SP 238	SP 254
F	SP 143	SP 159	SP 175	SP 191	SP 207	SP 223	SP 239	SP 255

International Character Sets

Country	ASCII code (Hex)													
	23	24	25	2A	40	5B	5C	5D	5E	60	7B	7C	7D	7E
USA	#	\$	%	*	@	[¥]	^	`	{		}	~
France	#	\$	%	*	à	°	ç	§	^	`	é	ù	è	¨
Germany	#	\$	%	*	§	Ä	Ö	Ü	^	`	ä	ö	ü	ß
U.K.	£	\$	%	*	@	[¥]	^	`	{		}	~
Denmark I	#	\$	%	*	@	Æ	Ø	Å	^	`	æ	ø	å	~
Sweden	#	¤	%	*	É	Ä	Ö	Å	Ü	é	ä	ö	å	ü
Italy	#	\$	%	*	@	°	¥	é	^	ù	à	ò	è	ì
Spain I	Pt	\$	%	*	@	ı	Ñ	ı	^	`	¨	ñ	}	~
Japan	#	\$	%	*	@	[¥]	^	`	{		}	~
Norway	#	¤	%	*	É	Æ	Ø	Å	Ü	é	æ	ø	å	ü
Denmark II	#	\$	%	*	É	Æ	Ø	Å	Ü	é	æ	ø	å	ü
Spain II	#	\$	%	*	á	ı	Ñ	ı	é	`	í	ñ	ó	ú
Latin America	#	\$	%	*	á	ı	Ñ	ı	é	ü	í	ñ	ó	ú
Korea	#	\$	%	*	@	[₩]	^	`	{		}	~
Slovenia/Croatia	#	\$	%	*	Ž	Š	Đ	Ć	Č	ž	š	đ	ć	č
China	#	¥	%	*	@	[¥]	^	`	{		}	~