

The logo features the word "Intermec" in a bold, blue, sans-serif font. To its right is a square icon containing a stylized white circular graphic with a blue square in the center. The background consists of several overlapping, light gray circular lines of varying thicknesses, some with small gray dots at their intersections, creating a complex, orbital-like pattern.

Intermec



**Installation
Instructions**

6820 Printer

Intermec Technologies Corporation

World Headquarters
6001 36th Ave. W.
Everett, WA 98203
U.S.A.

www.intermec.com

The information contained herein is provided solely for the purpose of allowing customers to operate and service Intermec-manufactured equipment and is not to be released, reproduced, or used for any other purpose without written permission of Intermec Technologies Corporation.

Information and specifications contained in this document are subject to change without prior notice and do not represent a commitment on the part of Intermec Technologies Corporation.

© 2007 Intermec Technologies Corporation. All rights reserved.

The word Intermec, the Intermec logo, Norand, ArciTech, Beverage Routebook, CrossBar, dcBrowser, Duratherm, EasyADC, EasyCoder, EasySet, Fingerprint, INCA (under license), i-gistics, Intellitag, Intellitag Gen2, JANUS, LabelShop, MobileLAN, Picolink, Ready-to-Work, RoutePower, Sabre, ScanPlus, ShopScan, Smart Mobile Computing, TE 2000, Trakker Antares, and Vista Powered are either trademarks or registered trademarks of Intermec Technologies Corporation.

There are U.S. and foreign patents as well as U.S. and foreign patent applications pending.

Bluetooth is a trademark of Bluetooth SIG, Inc., U.S.A.

Contents

| | |
|---|----|
| Global Services and Support | iv |
| Warranty Information | iv |
| Web Support | iv |
| Telephone Support | iv |
| Using the Installation Kit | 7 |
| Installation Procedures | 7 |
| Tools Required | 7 |
| Installing the Battery Cable | 7 |
| Installing the Direct-to-Battery Cable | 8 |
| Routing Cables | 8 |
| Preparing the Vehicle Battery Cable | 9 |
| Connecting to the Vehicle Battery | 10 |
| Connecting to a Two Battery Vehicle System | 13 |
| Securing the Vehicle Battery Cable | 13 |
| Grounding the Printer Power Cables | 14 |
| Verifying the Printer Power Cable Voltage | 15 |
| Installing the Printer | 16 |
| Fixed Mount Printer P/N 709-850-006 Mounting Plate (Optional) | 16 |
| Wall Mount Printer Kits | 19 |
| Contents of Flat Paper Tray - P/N 203-486-00 | 19 |
| Contents of Compact Paper Tray - P/N 203-489-001 | 20 |
| Installing the Mounting Plate | 23 |
| Attaching Either Paper Tray to the Mounting Plate | 24 |
| Mounting the Printer | 25 |

Global Services and Support

This section provides you with safety information, technical support information, and sources for additional product information.

Safety Information

Your safety is extremely important. Read and follow all warnings and cautions in this document before handling and operating Intermec equipment. You can be seriously injured, and equipment and data can be damaged if you do not follow the safety warnings and cautions.

This section explains how to identify and understand dangers, warnings, cautions, and notes that are in this document. You may also see icons that tell you when to follow ESD procedures and when to take special precautions for handling optical parts.



A warning alerts you of an operating procedure, practice, condition, or statement that must be strictly observed to avoid death or serious injury to the persons working on the equipment.



A caution alerts you to an operating procedure, practice, condition, or statement that must be strictly observed to prevent equipment damage or destruction, or corruption or loss of data.



Note: Notes either provide extra information about a topic or contain special instructions for handling a particular condition or set of circumstances.

Global Services and Support

Warranty Information

To understand the warranty for your Intermec product, visit the Intermec web site at www.intermec.com and click **Service & Support > Warranty**.

Web Support

Visit the Intermec web site at www.intermec.com to download our current documents (in PDF). To order printed versions of the Intermec manuals, contact your local Intermec representative or distributor.

Visit the Intermec technical knowledge base (Knowledge Central) at intermec.custhelp.com to review technical information or to request technical support for your Intermec product.

Telephone Support

These are available from Intermec Technologies Corporation.

| Service | Description | In the U.S.A. and Canada, call 1-800-755-5505 and choose this option |
|-------------------------|--|---|
| Order Intermec products | <ul style="list-style-type: none">• Place an order.• Ask about an existing order. | 1 and then choose 2 |
| Order Intermec media | Order printer labels and ribbons. | 1 and then choose 1 |
| Order spare parts | Order spare parts | 1 or 2 and then choose 4 |
| Technical Support | Talk to technical support about your Intermec product. | 2 and then choose 2 |
| Service | <ul style="list-style-type: none">• Get a return authorization number for authorized service center repair.• Request an on-site repair technician. | 2 and then choose 1 |
| Service contracts | <ul style="list-style-type: none">• Ask about an existing contract.• Renew a contract.• Inquire about repair billing or other service invoicing questions. | 1 or 2 and then choose 3 |

Outside the U.S.A. and Canada, contact your local Intermec representative. To search for your local representative, from the Intermec web site, click **About Us > Contact**.

Service Location Support

For the most current listing of service locations, click **Support > Returns and Repairs > Repair Locations**.

For technical support in South Korea, use the after service locations listed below:

AWOO Systems
102-1304 SK Ventium
522 Dangjung-dong
Gunpo-si, Gyeonggi-do Korea, South 435-776
Contact: Mr. Sinbum Kang
Telephone: +82-31-436-1191
Email: sbkang@awoo.co.kr

IN Information System Ptd LTD
6th Floor
Daegu Venture Center Bldg 95,
Shinchum 3 Dong
Donggu, Daegu City, Korea
Email: jmyou@idif.co.kr OR korlim@gw.idif.co.kr

Using the Installation Kit

When the installation is complete, you will have a secure place to store the printer and hand-held or mobile computer. The vehicle electrical system provides power to operate the printer, vehicle dock; and charge the printer internal battery.

In this installation, the power cable is wired directly to the vehicle battery. This reduces installation problems and the vehicle battery filtering.

The installation kits contain all of the hardware (nuts, bolts, washers, a terminal ring, and a fuse link) for connecting the battery cable directly to the vehicle battery. These kits also contain adjustable wire clamps to secure the cable in place.



Note: These instructions are required to install the following kit numbers:
P/N 203-242-101 (Fixed Mount and Wall Mount Printers)
P/N 203-242-102 (Portable Printers).

The 6820 Printer and associated electrical wiring should be installed under the supervision of properly trained and qualified personnel. Follow these installation instructions to ensure safe, reliable performance of the 6820 Printer.

Installation Procedures

There are three steps to install your printer

- 1 Installing the battery cable.
- 2 Installing the printer.
- 3 Performing the final assembly and cable connection.

Tools Required

You should have a wire crimping and stripping tool, an electric drill with 3/16" and 9/16" drill bits, and common hand tools.

Installing the Battery Cable



Note: If the vehicle voltage is too high or too low, the printer may not work.

The vehicle electrical system must be in good condition for all types of installations. The charging circuit must work properly and vehicle generated electrical "noise" must be minimized.

To determine your vehicle's voltage level

- 1 Measure the vehicle battery voltage with a voltmeter. It should read approximately 13.0 V DC with the engine **OFF**.

- 2 Start the vehicle engine. Continue monitoring the battery's voltage while you run the engine at a fast idle for five minutes. The voltage should read below 14.5 V DC. It must not exceed 18.0 V.



Note: For 24 V vehicle systems check each battery individually.



Note: If the battery voltage exceeds 18.0 V DC, there is a problem with the vehicle electrical system which must be diagnosed and repaired before the printer and vehicle dock will work properly. Check your engine for a bad voltage regulator or a poor ground, either of which cause excessive voltage.

Excess electrical noise can be severe enough to defeat the electrical filtering that is built into Intermec cables, printers, and vehicle docks. Defective ignition wiring, damaged insulation, or a faulty vehicle electrical component can cause electrical noise — possibly causing unpredictable behavior in printers and docks.

Installing the Direct-to-Battery Cable

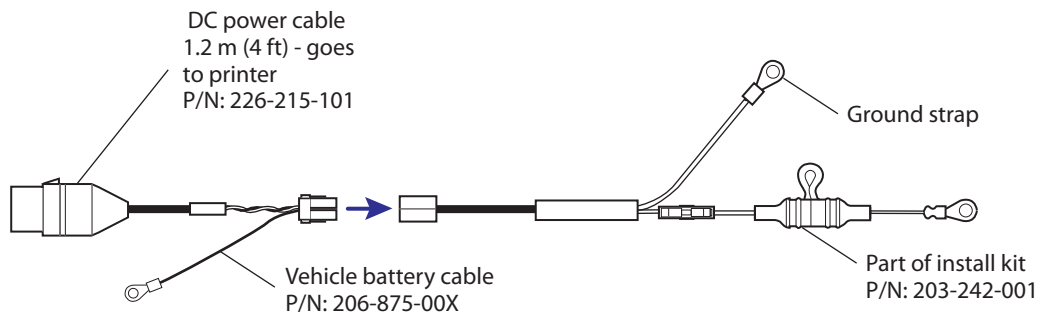

Connect printers directly to the battery based on the following criteria:

- The vehicle battery acts as an electrical filter and regulator.
- If there is any damage to the printer dc power cable, the cable is easily replaced.

Routing Cables

Use the following guidelines when routing the printer DC power cable and the vehicle battery cable:

- Route the vehicle battery cable from the area where the printer is to be mounted toward the vehicle battery.
- When possible, route the printer power cable along with existing vehicle wiring. Use cable ties to join the cable and wiring together.
- Use a snap-in bushing (requires 9/16" hole) if the vehicle battery cable passes through the firewall or other sheet-metal.

- Make sure that cable routing does not interfere with other equipment or vehicle controls.
- Ensure that cable routing does not invite damage to the cable.
- Secure the vehicle battery cable at least every 18” (50 cm) throughout the cable run: use adjustable clamps (provided) or wire-tie to existing vehicle cable runs.
- Completely install the printer power cable and take voltage measurements before connecting the printer.

Preparing the Vehicle Battery Cable

After you route the vehicle battery cable to the vehicle battery, do the following to prepare the vehicle battery cable for the terminal ring and fuse link assembly.

Strip the Vehicle Battery Cable Jacket

To strip the gray vehicle battery cable jacket and insulation

- 1 Cut the gray battery cable near the battery to avoid coiling or tying excess cable.
- 2 Strip the battery cable jacket (gray) back 12-14” (31-36 cm).
- 3 Strip 1/4” (6 mm) of insulation from the black (or brown) and red wires.

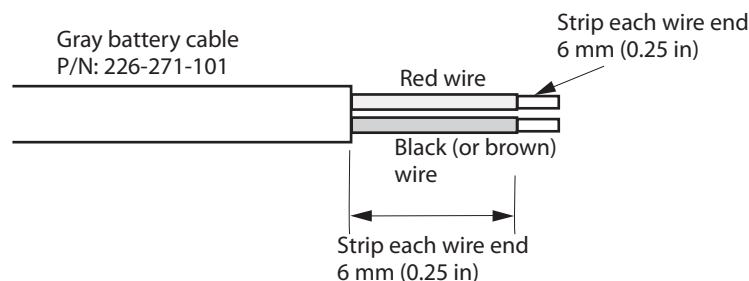

Crimping Cable Ends

To attach a terminal ring and a preassembled in-line fuse link to the vehicle battery cable.



Note: You may have to shorten and restrip the red wire when attaching the fuse link assembly.

- 1 Strip the black wire.
- 2 Crimp the 3/8” terminal ring (P/N 809-165-001) onto the black wire.
- 3 Attach the fuse link assembly (P/N 315-071-002) to the red wire (if needed, shorten red wire), strip 1/4” (6 mm) of insulation off the red wire.

- 4 Crimp the red wire onto the fuse link.

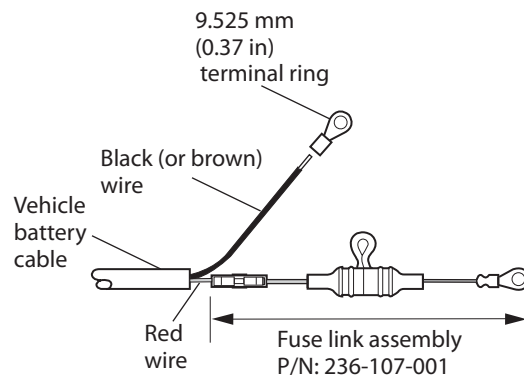

Connecting to the Vehicle Battery

Your vehicle has either a top-mount battery with the terminals on the top, a side-mount battery with terminals on the side, or two top-mount batteries with the terminals on the top. Determine which battery is in your vehicle and proceed with applicable instructions.

Connecting to a Side-Mount Vehicle Battery

To attach the vehicle battery cable to a side-mount battery terminal

- 1 Disconnect the negative battery cable, then disconnect the positive battery cable, and remove the bolts from each cable.
- 2 Screw a 3/8" nut as far as it will go onto a 3/8" x 1-1/2" bolt furnished in kit, then slip a 3/8" washer onto the bolt.
- 3 Slide the positive (red wire with fuse link) terminal ring from the printer power cable onto the bolt.
- 4 Slip a second 3/8" washer, then slip the vehicle positive battery cable onto the bolt.
- 5 Thread bolt assembly (Steps 2 through 4) into the positive (+) battery terminal.
- 6 Securely tighten the bolt, then the nut installed in Step 2 to secure washers and cables into place.

- 7 Repeat Steps 2 through 6 for the negative vehicle battery cable wire (black or brown), hooking up the negative cable to the negative battery terminal.

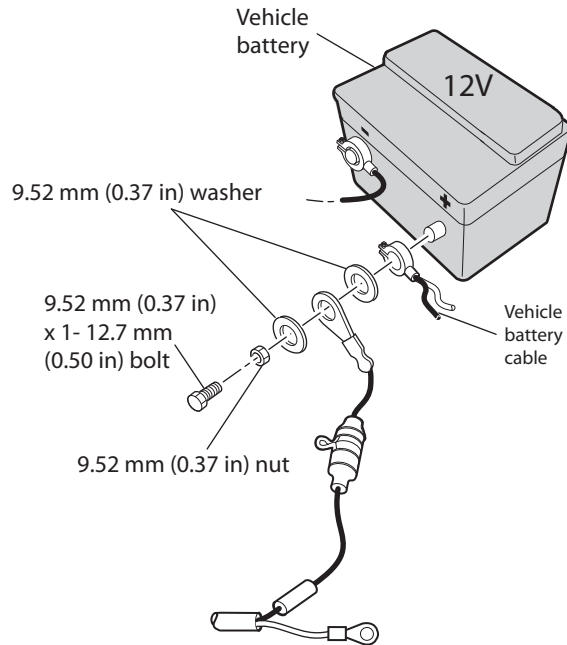

Connecting to a Top-Mount Vehicle Battery

To attach the vehicle battery cable to a top-mount battery terminal

- 1 Disconnect the negative battery cable, then disconnect the positive battery cable.
- 2 Remove the bolts from the battery cable and replace these bolts with 3/8" x 1-1/2" bolts and nuts furnished in the installation kit.
- 3 Reinstall the positive battery cable, then tighten the nut securely.
- 4 Slip a 3/8" washer onto the extended end of each bolt.
- 5 Slide the positive (fuse link with red wire) terminal ring from the printer power cable onto the positive (+) battery bolt.
- 6 Slip a second 3/8" washer onto the bolt, then thread and tighten a second 3/8" nut onto that bolt.

7 Repeat Steps 5 through 6 for the negative battery cable wire (black or brown), connecting the wire to the negative battery terminal.

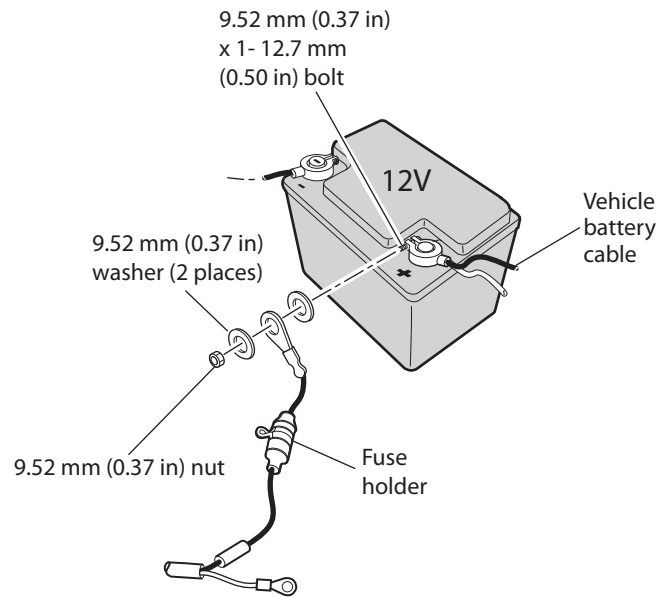

Connecting to a Two Battery Vehicle System

The following illustration shows how to connect to a 24 V two battery system by wiring the printer to one of the batteries.

Correct Connection Method

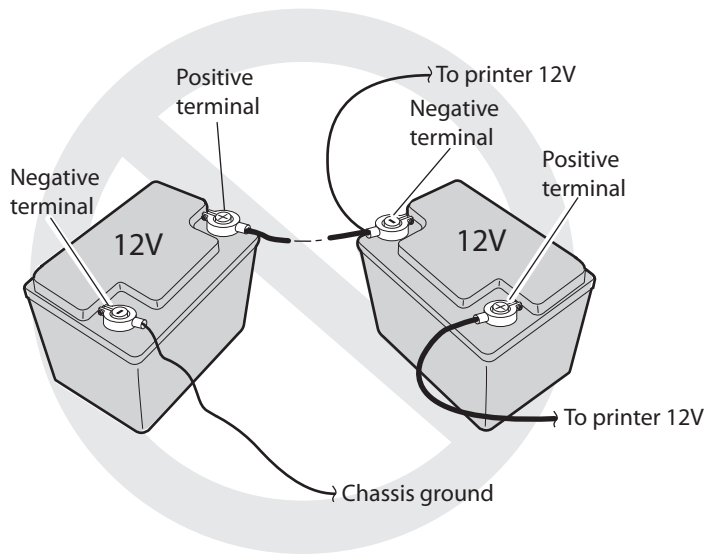
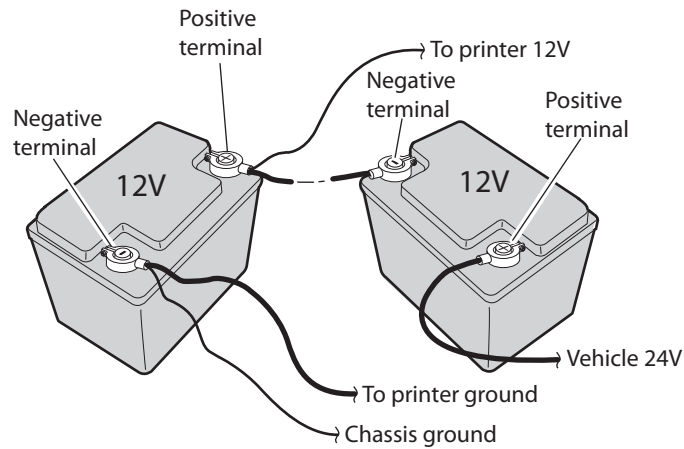

Connecting to a Two Battery Vehicle System

Securing the Vehicle Battery Cable

To secure the vehicle battery cable

- 1 Secure the vehicle battery cable every 18" (50 cm) with adjustable cable clamps. Work from the battery to the mounting area for the printer.

- 2 Remove the paper backing from a clamp (P/N: 807-059-001) and stick the clamp in place while drilling a pilot hole with a #26 drill bit. Use #6 sheet-metal screws to permanently hold clamps in place.

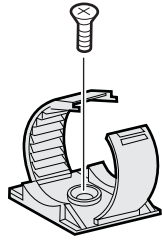

Grounding the Printer Power Cables

The printer power cable has a ground strap that must fasten to vehicle sheet-metal to ensure proper cable shielding. This ground strap is the wire with a ring terminal by the white connectors between the DC power cable and the vehicle battery cable.

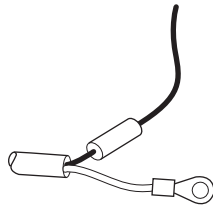

To fasten the ground strap:

- 1 Drill a small hole (slightly smaller than the screw diameter) where to fasten the chassis ground strap for the power cable connector. Use a punch to dimple and enlarge the hole.
- 2 Scrape a small circle of paint from around the hole to ensure a good electrical connection.
- 3 Use a #8 x 5/8" screw and flat washer to secure the strap.

Verifying the Printer Power Cable Voltage



Note: This is the correct polarity for 6820 Printers.

Verify the printer power cable voltage and polarity (as indicated), then plug the printer DC power cable into the printer power connector.

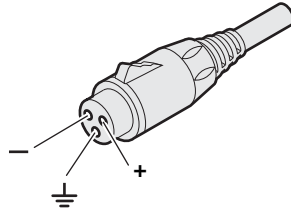

Use a volt meter to test the cable before connecting the cable to the 6820 Printer. Set the voltmeter for DC volts.

Voltmeter Readings for Printer Power Cable

| Voltmeter Red Lead | Voltmeter Black Lead | Reading DC Volts | Meaning |
|--------------------|----------------------|------------------|---|
| Pin 1 | Pin 2 | 12-15 | <ul style="list-style-type: none">• If zero volts, check the battery connections.• If a negative voltage, the wires on the battery are reversed. <i>Do not connect to printer.</i>• If less than 12 volts, vehicle battery or connections are bad• If more than 15 volts, connection is across more than one 12-volt battery or truck charging system is faulty. <i>Do not connect to printer.</i> |
| Pin 1 | Pin 3 | 12-15 | If zero volts, check the connection done on the previous page. |
| Pin 2 | Pin 3 | 0 | If not zero volts, check the connection to the battery negative terminal and the connection done on the previous page. |

Installing the Printer

The fixed mount printer and wall mount printer each has its own mounting plate option. A mounting plate is not available for the portable printer with the 50-sheet paper tray.

Fixed Mount Printer P/N 709-850-006 Mounting Plate (Optional)

The angle mounting plate and printer footprint are for the fixed mount printers. Note the keyholes cut into the bottom of the oversize paper tray. These keyholes allow you to install or remove the fixed mount printer from a vehicle without using any special tools. Sliding latches in the tray bottom hold the printer securely

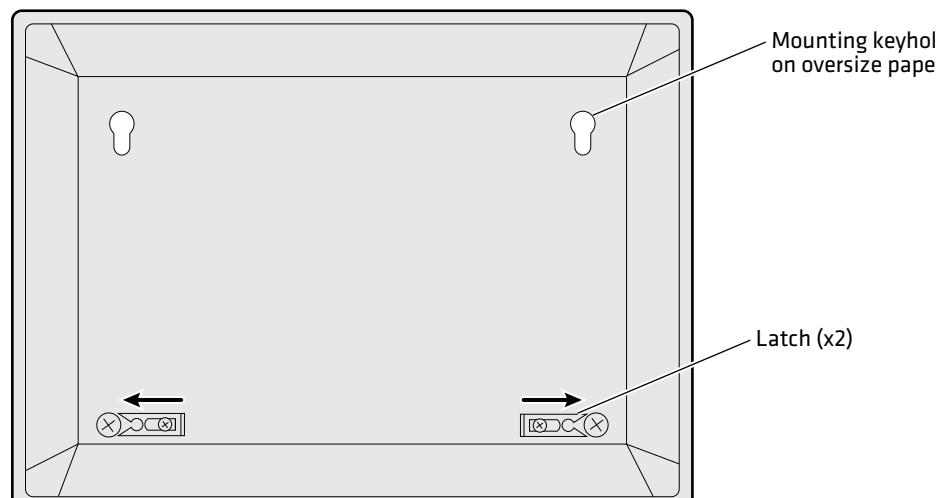

Note: Nuts and bolts are not provided. You must locally select and purchase hardware that provides the most secure installation possible for the application and vehicle.

Once you select where to install the fixed mount printer in the vehicle, you permanently install the plate. The following angle mounting plate has access holes where necessary so special tools are not required for securely tightening hardware.

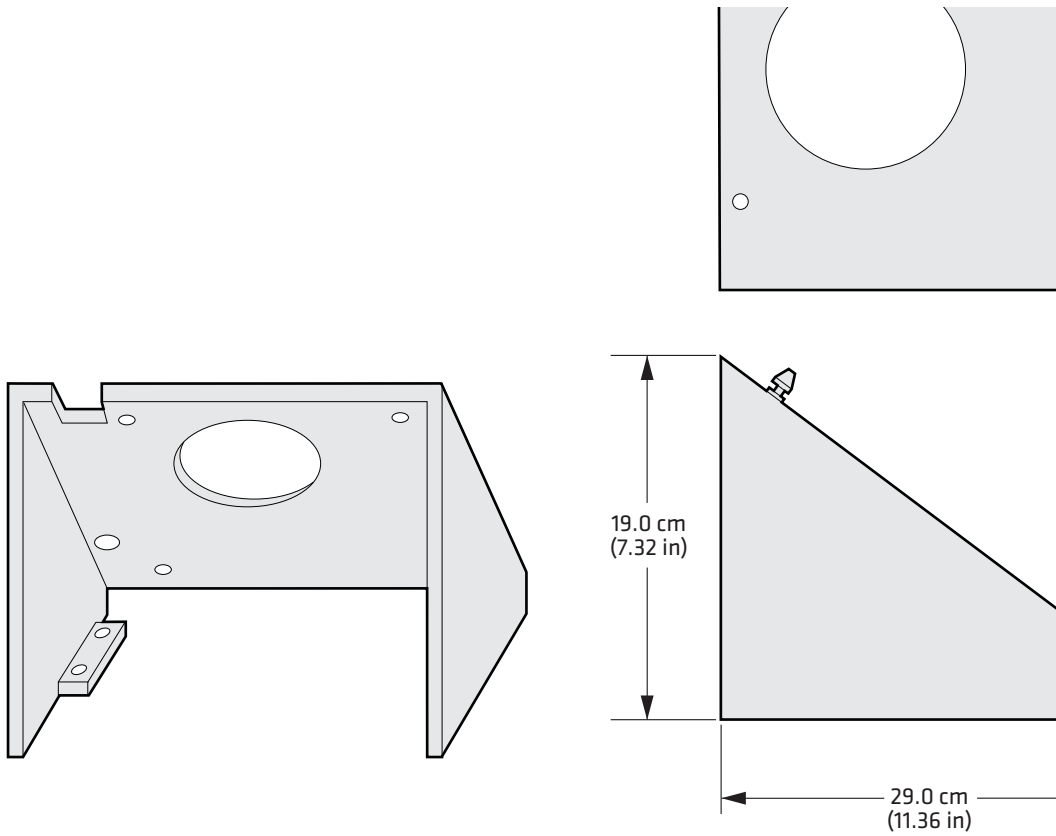

Angle Mounting Plate (P/N 709-850-006)

The following flat mounting plate has access holes where necessary so special tools are not required for securely tightening hardware.

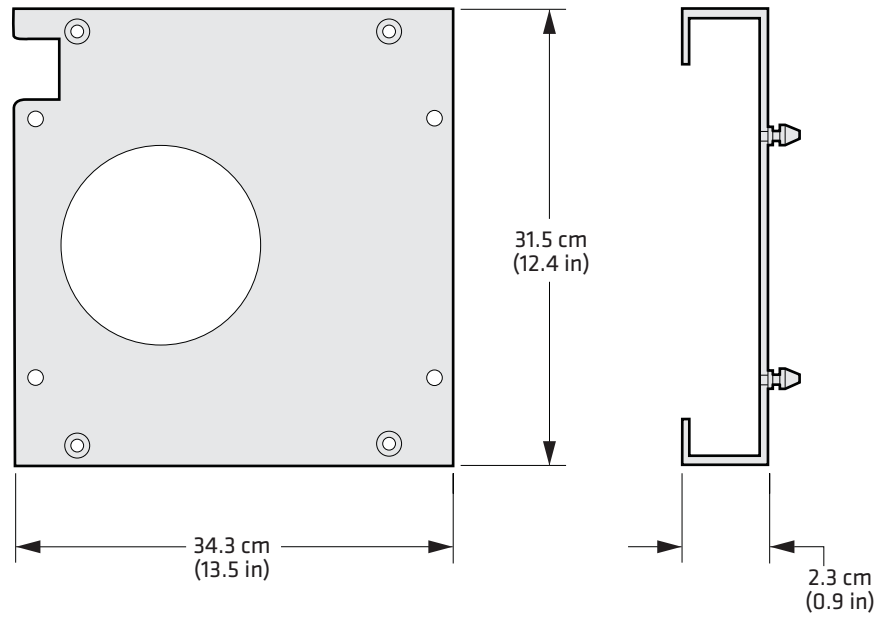

Flat Mounting Plate (P/N 709-966-006)

Wall Mount Printer Kits

Contents of Flat Paper Tray - P/N 203-486-002

| Part Number | Description |
|-------------|-----------------------------------|
| 754-548-002 | Flat Paper Tray |
| 714-417-001 | Mounting Plate |
| 801-194-003 | 6 1/4" - 20 1/2" bolts (3 needed) |
| 803-041-000 | 6 1/4" split washers |
| 754-546-002 | Adapter bracket (discard) |

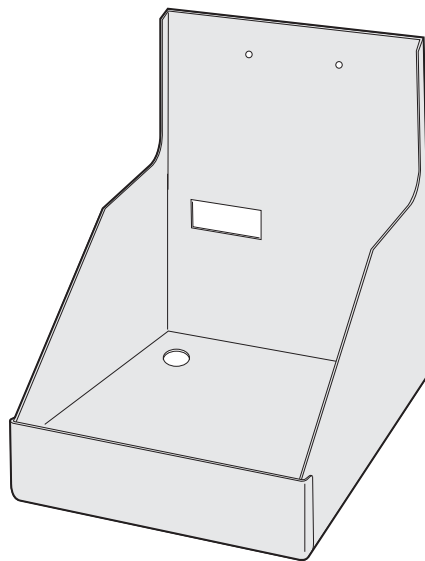

754-548-002 Flat paper tray

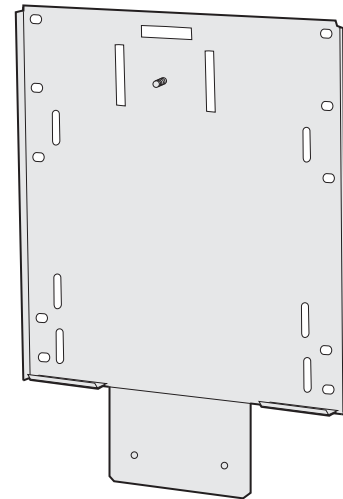

714-417-001 Mounting plate

The 714-417-001 Mounting Plate also includes a 5" x 4" plate adapter bracket and knob.

Contents of Compact Paper Tray - P/N 203-489-001

| Part Number | Description |
|-------------|------------------------|
| 650-447-001 | Compact Paper Tray |
| 801-194-003 | 2 1/4" - 20 1/2" bolts |
| 803-041-000 | 2 1/2 split washers |

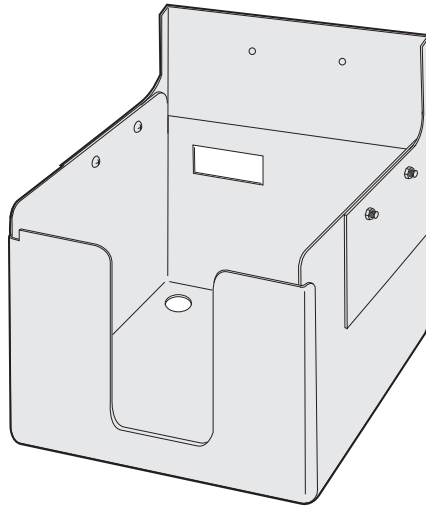

650-447-001 Compact paper tray

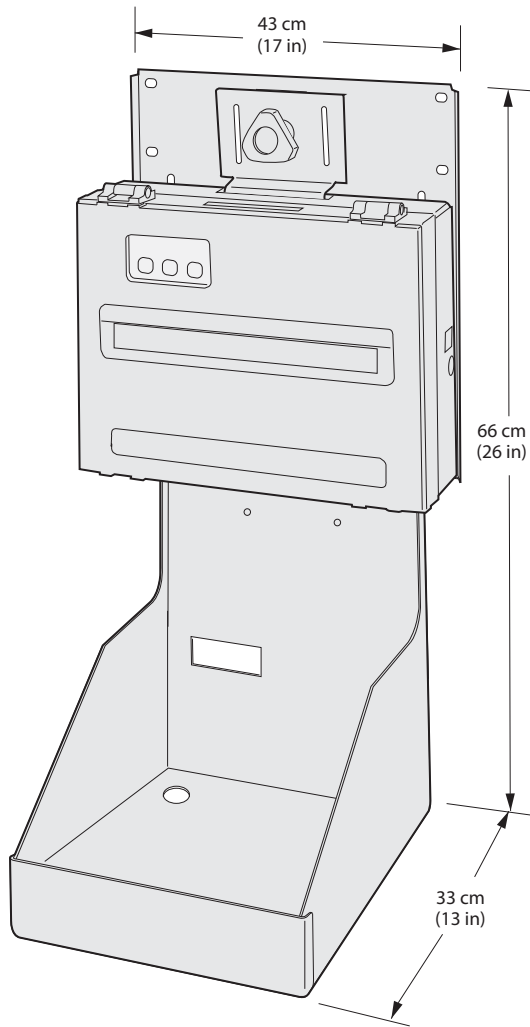

You need a space that is 17" x 26" x 13" (43 cm x 66 cm x 33 cm) for the mounting plate, wall mount printer, and flat paper tray.

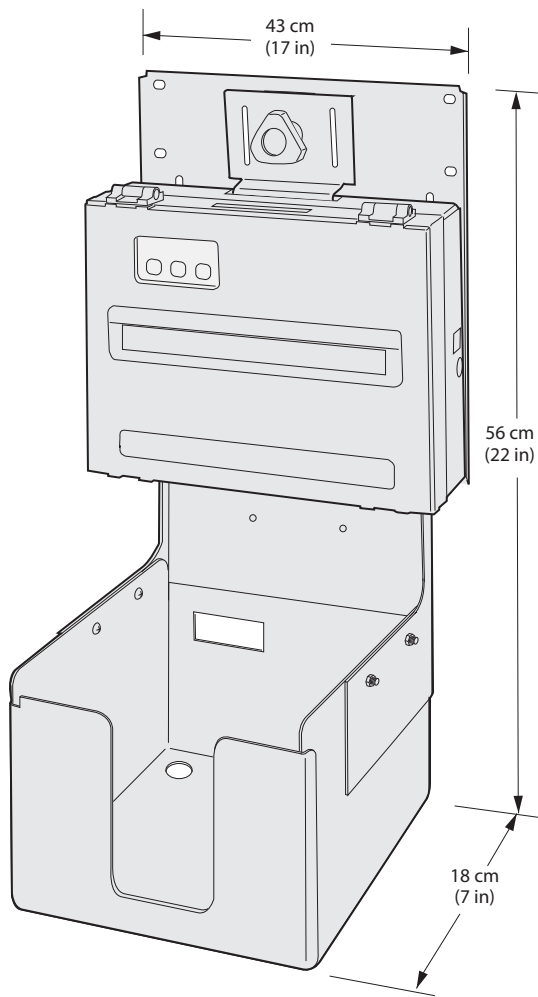

17" x 22" x 7" (43 cm x 56 cm x 18 cm) is required for the mounting plate, wall mount printer, and compact paper tray.

Installing the Mounting Plate

The mounting plate for the wall mount printer hangs on the wall of a vehicle. Install the plate with the knob screw on top and the mounting lips facing outward. Use four bolts, evenly distributed, to secure the plate to the vehicle wall. Note that the bolts are not included in the kit, you will have to supply the bolts.

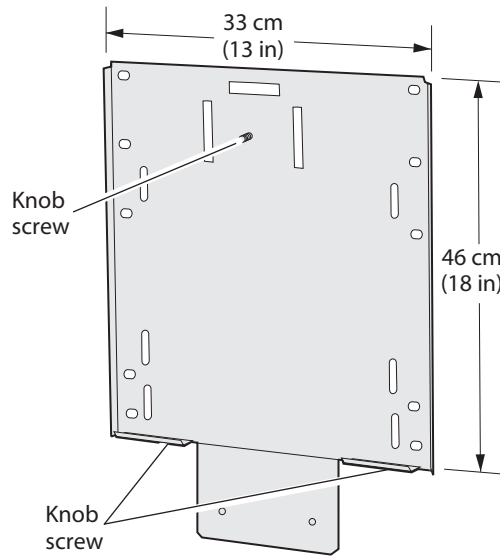

Attaching Either Paper Tray to the Mounting Plate

Use two bolts to attach either the flat paper tray or the compact paper tray to the center, bottom lip of the mounting plate. The holes in the mounting plate are threaded.

To attach to the mounting plate

- 1 Position the center lip on either paper tray over the center, bottom lip on the mounting plate. The two holes in the paper tray should align with the holes in the center, bottom lip of the mounting plate.
- 2 Hold either paper tray in place and insert two 1/4"-20 x 1/2" bolts (with 1/2" split washers) in the holes, through the paper tray. Use a 7/16" wrench to tighten the bolts.

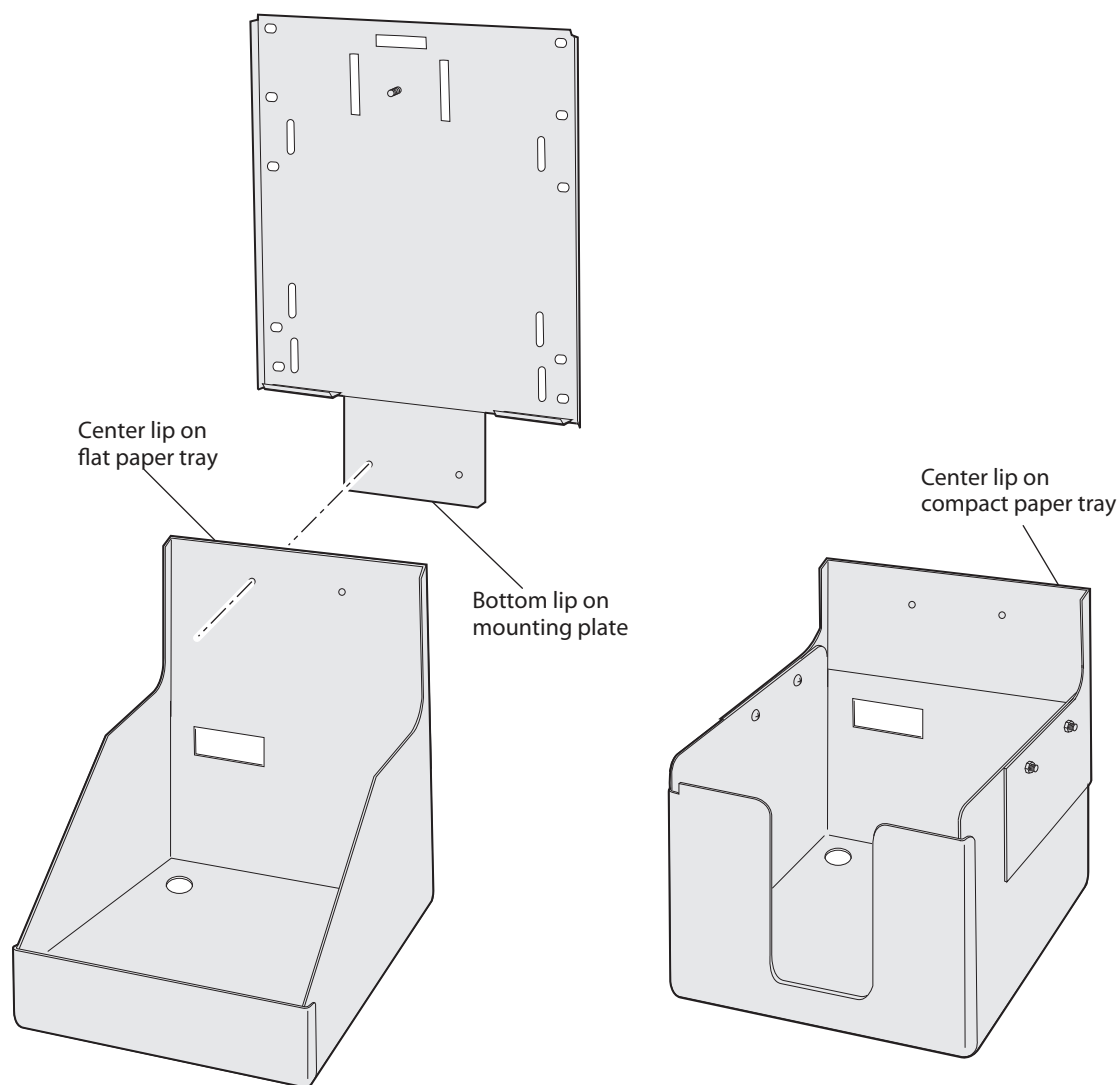

Mounting the Printer

The wall mount printer sits on the bottom lip of the mounting plate. The top of the printer is held to the plate via a 5" x 4" plate adaptor bracket and a knob.

To mount the printer

- 1 Using the two slots on the printer bottom, push the printer onto the two bottom lips on the mounting plate. Hold the printer against the mounting plate.
- 2 Set the plate adaptor bracket into the horizontal slot at the top of the printer, then align and turn the black knob clockwise onto the knob screw to tighten the bracket onto the mounting plate

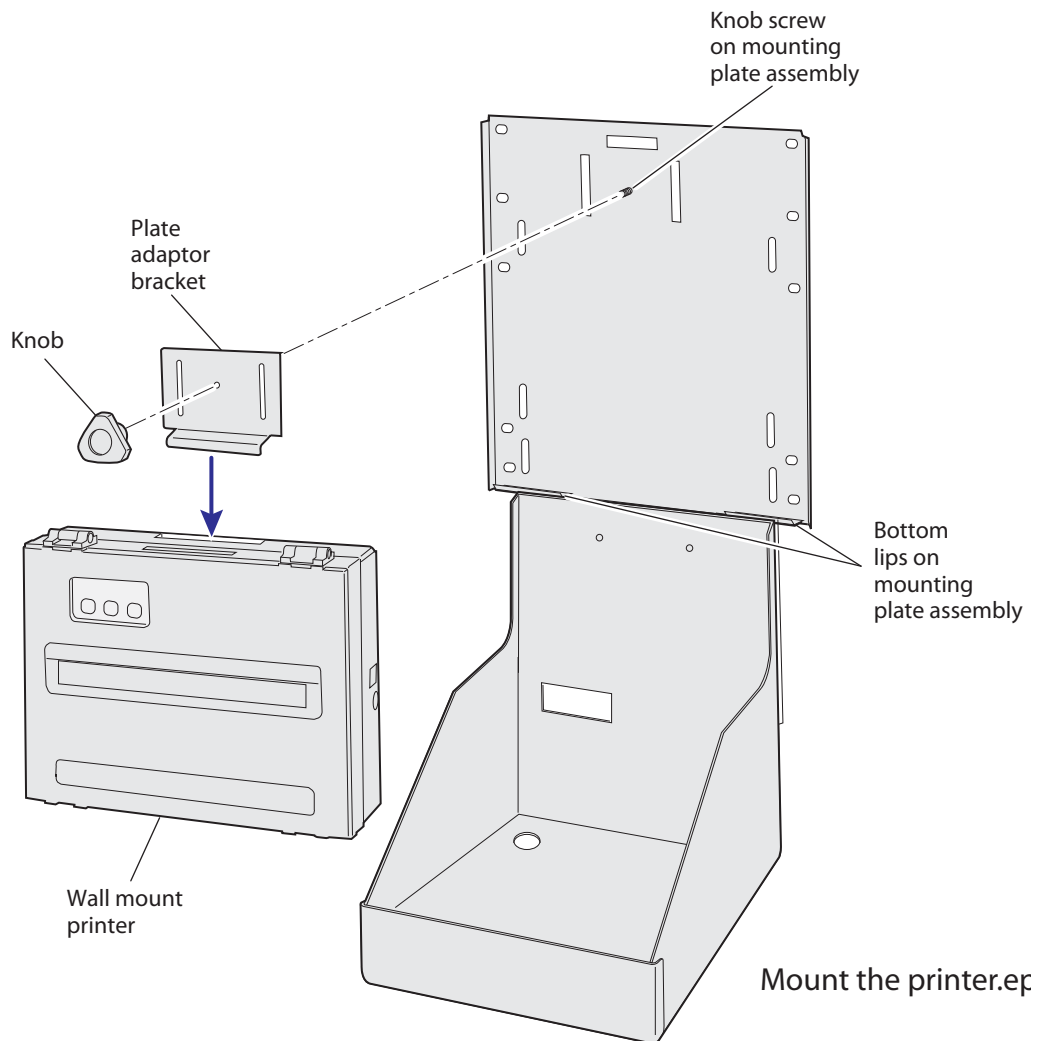



Worldwide Headquarters
6001 36th Avenue West
Everett, Washington 98203
U.S.A.

tel 425.348.2600

fax 425.355.9551

www.intermec.com

© 2007 Intermec Technologies
Corporation. All rights reserved.

6820 Printer Installation Instructions



P/N 931-052-001