



# Maintenance and Service Guide

HP RP9 G1 Retail System

© Copyright 2016 HP Development Company, L.P.

ENERGY STAR® is a registered mark owned by the U.S. government. Microsoft and Windows are either registered trademarks or trademarks of Microsoft Corporation in the United States and/or other countries.

The information contained herein is subject to change without notice. The only warranties for HP products and services are set forth in the express warranty statements accompanying such products and services. Nothing herein should be construed as constituting an additional warranty. HP shall not be liable for technical or editorial errors or omissions contained herein.

First Edition: February 2016

Document Part Number: 834296-001

### **Product notice**

This guide describes features that are common to most models. Some features may not be available on your computer.

Not all features are available in all editions of Windows 8. This computer may require upgraded and/or separately purchased hardware, drivers and/or software to take full advantage of Windows 8 functionality. See <http://www.microsoft.com> for details.

This computer may require upgraded and/or separately purchased hardware and/or a DVD drive to install the Windows 7 software and take full advantage of Windows 7 functionality. See <http://windows.microsoft.com/en-us/windows7/get-know-windows-7> for details.

### **Software terms**

By installing, copying, downloading, or otherwise using any software product preinstalled on this computer, you agree to be bound by the terms of the HP End User License Agreement (EULA). If you do not accept these license terms, your sole remedy is to return the entire unused product (hardware and software) within 14 days for a refund subject to the refund policy of your place of purchase.

For any further information or to request a full refund of the computer, please contact your local point of sale (the seller).

## Safety warning notice

---

 **WARNING!** To reduce the possibility of heat-related injuries or of overheating the device, do not place the device directly on your lap or obstruct the device air vents. Use the device only on a hard, flat surface. Do not allow another hard surface, such as an adjoining optional printer, or a soft surface, such as pillows or rugs or clothing, to block airflow. Also, do not allow the AC adapter to contact the skin or a soft surface, such as pillows or rugs or clothing, during operation. The device and the AC adapter comply with the user-accessible surface temperature limits defined by the International Standard for Safety of Information Technology Equipment (IEC 60950-1).

---



---

# Table of contents

<b>1 Product overview</b>	<b>1</b>
Standard features	1
Unfolding the ergonomic stand	3
Rear components	4
<b>2 Illustrated parts catalog</b>	<b>5</b>
Computer major components	5
Optional displays and USB devices	7
Cables and adapters	8
Storage devices	9
Misc parts	10
<b>3 Routine care, SATA drive guidelines, and disassembly preparation</b>	<b>11</b>
Electrostatic discharge information	11
Generating static	11
Preventing electrostatic damage to equipment	12
Personal grounding methods and equipment	12
Grounding the work area	12
Recommended materials and equipment	13
Routine care and maintenance	13
Drivers and firmware	13
Operating guidelines	13
Environmental specifications	14
Before you begin	14
Cleaning the computer case	14
Cleaning the monitor or touch screen	15
Cleaning I/O ports and fan area	15
Cleaning the keyboard	15
Cleaning the mouse	15
Cleaning the MSR	16
Service considerations	16
Power supply fan	16
Tools and software Requirements	16
Screws	16
Cables and connectors	16
Hard Drives	17

Lithium coin cell battery .....	17
SATA hard drives .....	17
SATA hard drive cables .....	18
SATA data cable .....	18
SMART ATA drives .....	18
Cable management .....	18

#### **4 Removal and replacement procedures ..... 19**

Preparation for disassembly .....	19
Installing a port cover .....	20
Removing and attaching the ergonomic and compact stands .....	21
Routing cables (ergonomic stand) .....	24
Routing cables (compact stand) .....	24
Removing and replacing the power supply (ergonomic stand) .....	25
Rear cover and shield .....	28
Installing an optional HP integrated USB barcode scanner, magnetic strip reader (MSR), biometric reader, or webcam .....	29
Installing an optional HP integrated USB module on the sides or top of the display head .....	29
Installing an optional HP integrated USB barcode scanner on the bottom of the display head .....	31
Installing a 2 x 20 LCD or 7" LCD customer facing display (CFD) .....	32
Installing a top mount CFD .....	32
Installing a bottom mount CFD .....	33
Installing memory .....	35
DDR4-SDRAM SODIMMs .....	35
Removing and installing a SODIMM .....	36
Removing and installing a 2.5-inch hard drive .....	37
Removing and installing an M.2 storage device .....	39
Replacing the battery .....	41
WLAN module .....	42
Hard drive bracket .....	43
VESA mount bracket .....	44
Heat sink .....	46
Processor .....	47
Fan .....	48
Rear trim .....	49
USB port .....	50
Speakers .....	51
Antennas .....	52
System board .....	53
System board callouts .....	56
Display panel assembly .....	57

Power board .....	59
<b>5 Configuring the software .....</b>	<b>60</b>
Touch screen calibration .....	60
Calibration for Windows 7 Professional and Embedded POSReady 7 .....	60
Calibration for Windows 8.1 Professional and Embedded 8.1 Industry Pro Retail .....	60
Calibration for Windows 10 Professional and Windows 10 IoT Enterprise for Retail .....	60
Configuring all optional HP integrated USB peripheral modules (HP integrated USB barcode scanner, magnetic strip reader (MSR), biometric reader, or webcam) .....	61
Configuring powered serial ports .....	61
<b>6 Computer Setup (F10) Utility .....</b>	<b>62</b>
Computer Setup (F10) Utilities .....	62
Using Computer Setup (F10) Utilities .....	62
Computer Setup—Main .....	64
Computer Setup—Security .....	66
Computer Setup—Advanced .....	68
Recovering the Configuration Settings .....	73
<b>7 POST error messages and diagnostic front panel LEDs and audible codes .....</b>	<b>74</b>
POST numeric codes and text messages .....	74
Interpreting system validation diagnostic front panel LEDs and audible codes .....	79
<b>8 Password security and resetting CMOS .....</b>	<b>81</b>
Resetting the password jumper .....	81
Changing a Setup or Power-On password .....	82
Deleting a Setup or Power-On password .....	83
Clearing and resetting the CMOS .....	83
<b>9 Using HP PC Hardware Diagnostics (UEFI) .....</b>	<b>85</b>
Downloading HP PC Hardware Diagnostics (UEFI) to a USB device .....	85
<b>10 Troubleshooting without diagnostics .....</b>	<b>87</b>
Safety and comfort .....	87
Before you call for technical support .....	87
Helpful hints .....	88
Solving retail system-specific problems .....	89
Solving general problems .....	90
Solving hard drive problems .....	94
Solving audio problems .....	97

Solving printer problems .....	99
Solving hardware installation problems .....	100
Solving Network Problems .....	101
Solving memory problems .....	104
Solving USB flash drive problems .....	105
Solving Internet access problems .....	106
Solving software problems .....	108
<b>11 System backup and recovery .....</b>	<b>109</b>
Backing up, restoring, and recovering in Windows 10 .....	109
Creating recovery media and backups .....	109
Creating HP Recovery media (select products only) .....	109
Using Windows tools .....	111
Restore and recovery .....	111
Recovering using HP Recovery Manager .....	111
What you need to know before you get started .....	111
Using the HP Recovery partition (select products only) .....	112
Using HP Recovery media to recover .....	112
Changing the computer boot order .....	113
Removing the HP Recovery partition (select products only) .....	113
Backing up, restoring, and recovering in Windows 8.1, Windows 8, or Industry 8.1 .....	113
Creating recovery media and backups .....	113
Restoring and recovering using Windows tools .....	114
Using Reset when the system is not responding .....	114
Recovery using the Windows recovery USB flash drive .....	115
Recovery using Windows operating system media (purchased separately) .....	115
Backing up, restoring, and recovering in Windows 7 and POSReady 7 .....	116
Creating recovery media .....	116
Creating recovery media using HP Recovery Manager (select models only) .....	117
Creating recovery discs with HP Recovery Disc Creator (select models only) .....	117
Creating recovery discs .....	118
Backing up your information .....	118
System Restore .....	119
System Recovery .....	119
System Recovery when Windows is responding .....	120
System Recovery when Windows is not responding .....	120
System Recovery using recovery media (select models only) .....	121
Using HP Recovery Disc operating system discs (select models only) .....	121
<b>Appendix A Power cord set requirements .....</b>	<b>123</b>
General requirements .....	123



Japanese power cord requirements ..... 123  
Country-specific requirements ..... 124

**Appendix B Specifications ..... 125**

**Index ..... 126**



---

# 1 Product overview

## Standard features



The HP RP9 G1 Retail System includes the following features.

- Integrated All-in-One (AiO) form factor
- Designed for long-term deployment within general retail, hospitality, and other markets
- 15.6" (Model 9015) and 18.5" (Model 9018) base models with Projected Capacitive touch technology and 1366 x 768 resolution
- VESA mounting holes (100 mm x 100 mm)
- Choice of ergonomic stand, compact stand, or no stand (Display Head unit only)
- Optional Integrated HP peripherals:
  - Integrated magnetic strip reader (left mount or right mount options, encryption capable)
  - 2 x 20 LCD customer facing display (rear top mount or bottom mount with extension arm)
  - 7" LCD customer facing display (rear top mount or bottom mount with extension arm)
  - Two integrated barcode scanners (one with left mount or right mount options, and one bottom mount only)
  - Integrated webcam (top mount only)
  - Integrated biometric fingerprint reader (left mount or right mount options)
- DDR4 2133 MHz Memory, up to 32GB maximum RAM
- Operating system choices:
  - Embedded 8.1 Industry ProRetail 64-bit
  - FreeDos 2.0
  - POSReady 7 32-bit

- POSReady 7 64-bit
- Windows 10 IoT Enterprise for Retail 64-bit
- Windows 10 Pro 64-bit
- Windows 10 Pro downgrade to Windows 7 Pro 32-bit
- Windows 10 Pro downgrade to Windows 7 Pro 64-bit
- Windows 10 Pro downgrade to Windows 8.1 Pro 64-bit
- Windows 7 Professional Edition 32-bit
- Windows 7 Professional Edition 64-bit
- Windows 8.1 Pro 64-bit
- One M.2 slot for optional WLAN
- Two USB 2.0 ports and two USB 3.0 ports
- One 24V powered USB port and three 12V powered USB ports, two powered serial ports, and one cash drawer port
- Audio line-in and line-out ports
- One DisplayPort for secondary display
- One 2.5" internal storage bay for SATA HDD or SSD
- Two M.2 internal storage bays
- Cable management features
- ENERGY STAR compliant

## Unfolding the ergonomic stand

If your model includes an ergonomic stand, the system is shipped with the stand in the folded position. Follow the steps below to unfold the stand.

1. Unfold the stand to the desired position.



2. Route the DC power cord through the cable retainer and connect the cord to the rear I/O power connector.

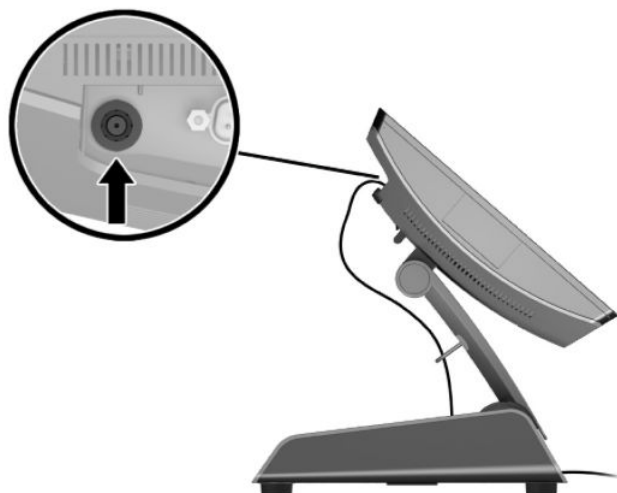

# Rear components

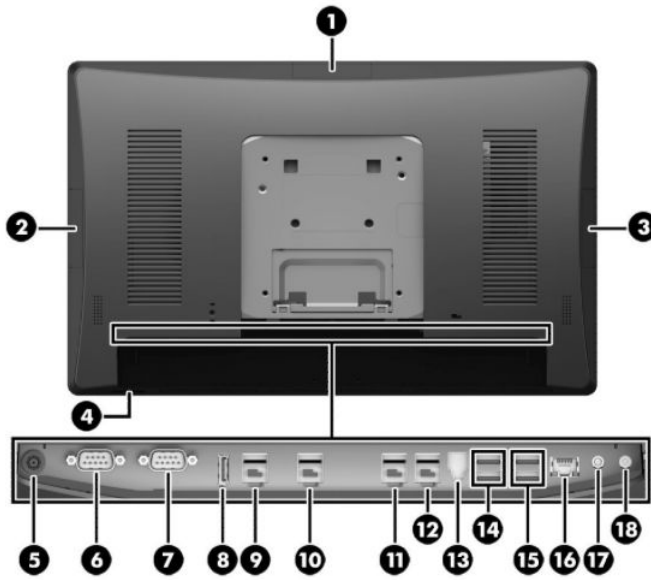

Item	Description	Item	Description
1	Top USB port for optional HP integrated USB webcam, 7" CFD, or 2 x 20 CFD (behind rear cover)	10	Powered USB 12V (B) used if the optional bottom mount barcode scanner is installed
2	Side USB port for optional HP integrated USB barcode scanner, MSR, or biometric reader (behind rear cover)	11	Powered USB 12V (C)
3	Side USB port for optional HP integrated USB barcode scanner, MSR, or biometric reader (behind rear cover)	12	Powered USB 24V
4	Power button	13	Cash drawer connector
5	DC In power connector	14	USB 2.0 ports
6	Powered serial port (COM A)	15	USB 3.0 ports
7	Powered serial port (COM B)	16	RJ-45 network connector
8	DisplayPort (for secondary display)	17	Audio line in connector
9	Powered USB 12V (A)	18	Audio line out connector

**NOTE:** The powered serial ports can be configured for 0V, 5V, or 12V.

**NOTE:** The 24-volt Powered USB connector and the 12-volt Powered USB connector are keyed differently as a precaution to prevent connection errors.

**NOTE:** The cash drawer connector is covered by a sticker that must be removed to connect the cash drawer cable.

**CAUTION:** The cash drawer connector is similar in size and shape to a modem jack. To avoid damage to the computer, DO NOT plug a network cable into the cash drawer connector.

## 2 Illustrated parts catalog

 **NOTE:** HP continually improves and changes product parts. For complete and current information on supported parts for your computer, go to <http://partsurfer.hp.com>, select your country or region, and then follow the on-screen instructions.

### Computer major components

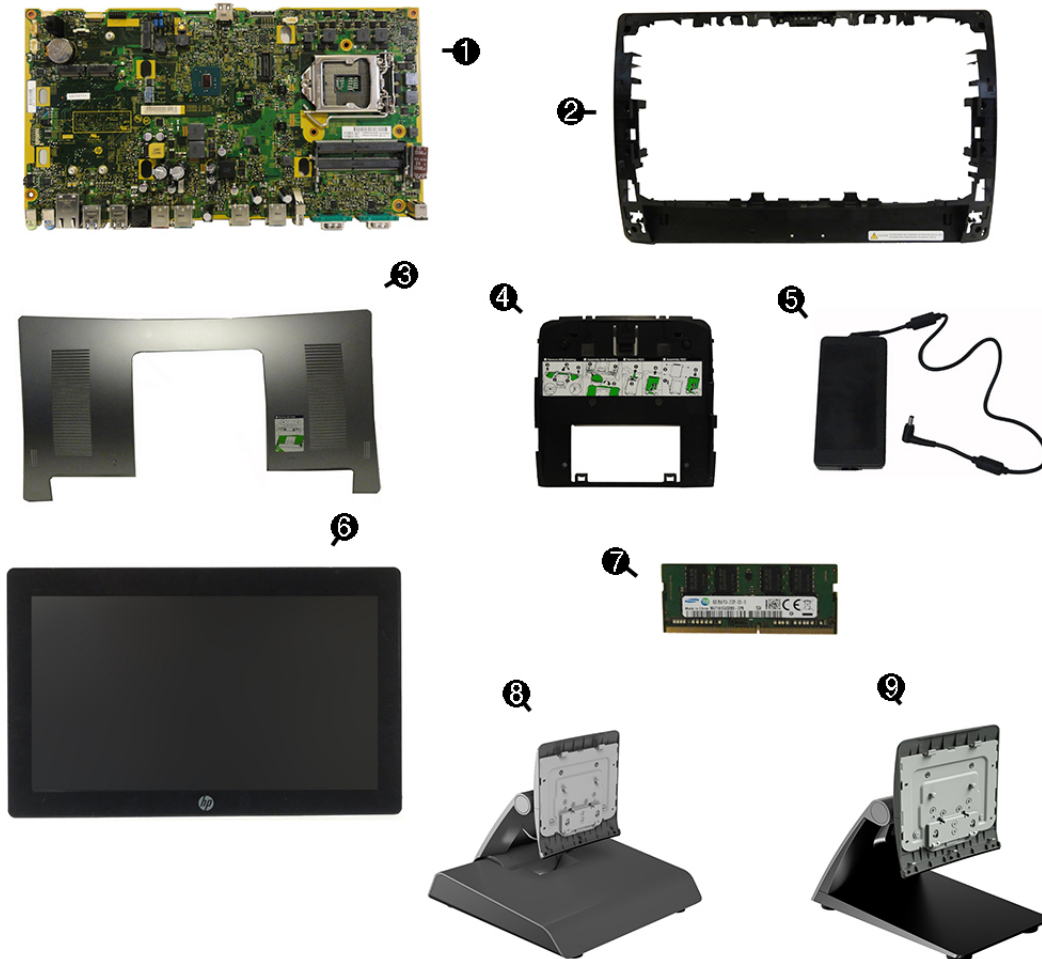

Item	Description
(1)	<b>System board</b> (includes replacement thermal material)
(2)	<b>Rear plastic trim</b>
	15.6- inch models
	18.5 inch models
(3)	<b>Rear cover</b>
	15.6-inch models

<b>Item</b>	<b>Description</b>
	18.5-inch models
<b>(4)</b>	<b>VESA bracket plastic cover</b>
<b>(5)</b>	<b>Power supply, 230W</b>
	Standard
	Slim
<b>(6)</b>	<b>Display panel assembly</b> (includes touch board that is pre-programmed to the touch glass)
	15.6-inch models
	18.5-inch models
<b>(7)</b>	<b>Memory modules</b> (SODIMM, PC4-17000, CL15)
	16 GB
	8 GB
	4 GB
	<b>Stand</b>
<b>(8)</b>	Ergonomic
<b>(9)</b>	Compact
	<b>Processor</b> (not illustrated)
	Intel Core i7-6700
	Intel Core i5-6500
	Intel Core i3-6100
	Intel Pentium G4400
	Intel Celeron G3900

\* not illustrated



## Optional displays and USB devices

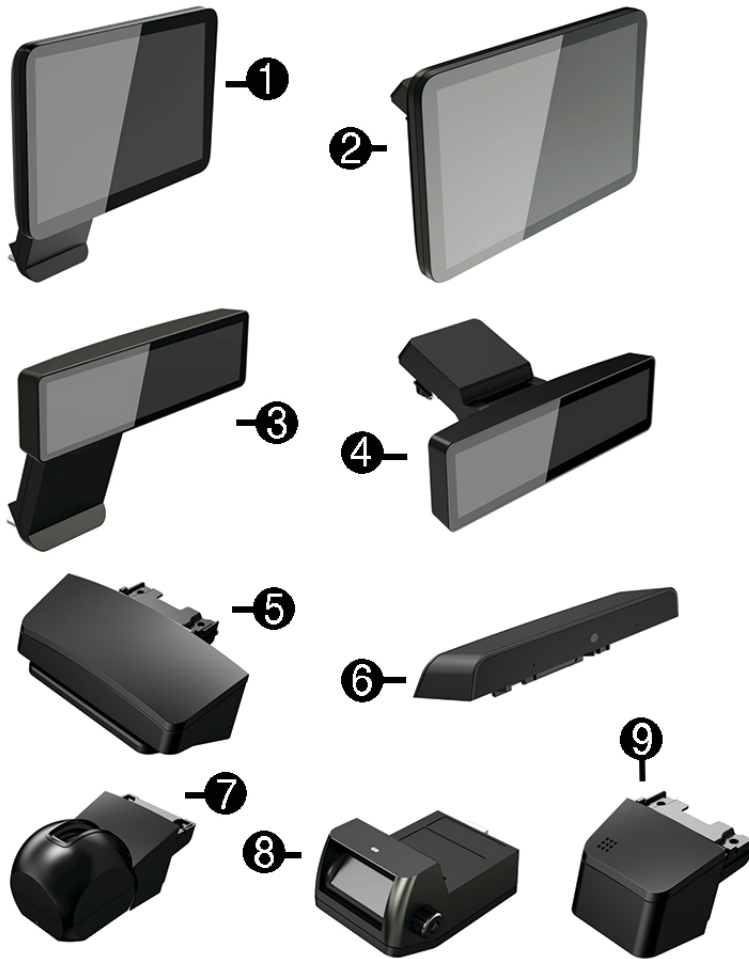

Item	Description
	<b>HP Retail Integrated 7-inch Customer Facing Display (with arm)</b>
(1)	Bottom mount
(2)	Top mount
	<b>HP Retail Integrated 2x20 Display (with arm)</b>
(3)	Bottom mount
(4)	Top mount
(5)	<b>HP Integrated Single-Head MSR</b>
(6)	<b>HP Retail Integrated Webcam</b>
	<b>HP Integrated Bar Code Scanner</b>
(7)	Left/right
(8)	Bottom
(9)	<b>HP Integrated Fingerprint Reader</b>

## Cables and adapters

Description
<b>USB board cable</b>
Right, 15.6-inch
Left, 15.6-inch
Right, 18.5-inch
Left, 18.5-inch
Top, 18.5-inch
<b>Hard drive connector and cable</b>
<b>Antennas and transceivers</b>
Left
Right
<b>Power board cable</b>
15.6-inch
18.5-inch
<b>DisplayPort cable</b>
<b>Adapters</b>
USB to serial
<b>DisplayPort to VGA</b>
<b>DisplayPort to DVI</b>
<b>DisplayPort to HDMI 1.4</b>

# Storage devices

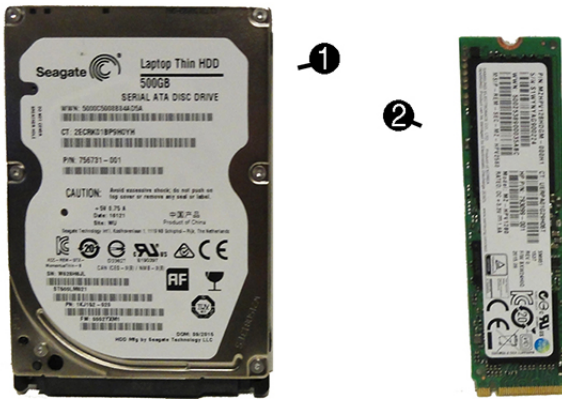

Item	Description
<b>(1)</b>	<b>Hard drives, 2.5-inch</b>
	1 TB, hybrid SSD
	500 GB, 7200 rpm, 2.5-inch, self-encrypting
	500 GB, 7200 rpm, 2.5-inch
	<b>Solid-state drives, 2.5-inch (not illustrated)</b>
<b>(2)</b>	256 GB Solid-state drive
	128 GB Solid-state drive
	128 GB Solid-state drive, self-encrypting (SED)
	120 GB Solid-state drive
	64-GB, flash, MLC
	<b>Solid-state drives, M.2</b>
	256 MB, PCIe
	256 MB, PCIe, NVMe
	256 MB
	128 MB, PCIe
128 MB, PCIe, NVMe	
128 MB	

\* not illustrated

# Misc parts

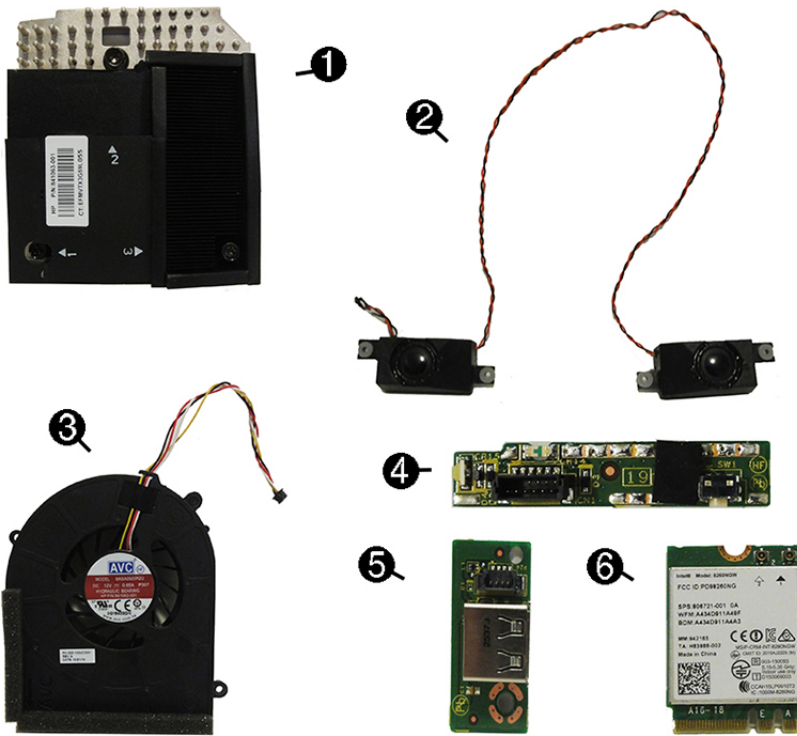

Item	Description
(1)	Heat sink
(2)	Speakers
	15.6-inch models
	18.5-inch models
(3)	Fan
(4)	Power board
(5)	USB port
(6)	WLAN module
	802.11 a/b/g/n + Bluetooth 4.0, 2x2
	802.11 a/b/g/n + Bluetooth 4.0, 2x2 (for use only in Indonesia)
	Intel Dual Band Wireless-AC 8260
*	Foot kit (includes rubber foot and screw)
*	Pad lock
*	I/O cover
*	Top port cover
*	Side port cover
*	Plug cover

\* not illustrated

# 3 Routine care, SATA drive guidelines, and disassembly preparation

This chapter provides general service information for the computer. Adherence to the procedures and precautions described in this chapter is essential for proper service.

**CAUTION:** When the computer is plugged into an AC power source, voltage is always applied to the system board. You must disconnect the power cord from the power source before opening the computer to prevent system board or component damage.

## Electrostatic discharge information

A sudden discharge of static electricity from your finger or other conductor can destroy static-sensitive devices or microcircuitry. Often the spark is neither felt nor heard, but damage occurs. An electronic device exposed to electrostatic discharge (ESD) may not appear to be affected at all and can work perfectly throughout a normal cycle. The device may function normally for a while, but it has been degraded in the internal layers, reducing its life expectancy.

Networks built into many integrated circuits provide some protection, but in many cases, the discharge contains enough power to alter device parameters or melt silicon junctions.

## Generating static

The following table shows that:

- Different activities generate different amounts of static electricity.
- Static electricity increases as humidity decreases.

Event	Relative Humidity		
	55%	40%	10%
Walking across carpet	7,500 V	15,000 V	35,000 V
Walking across vinyl floor	3,000 V	5,000 V	12,000 V
Motions of bench worker	400 V	800 V	6,000 V
Removing DIPs from plastic tube	400 V	700 V	2,000 V
Removing DIPs from vinyl tray	2,000 V	4,000 V	11,500 V
Removing DIPs from Styrofoam	3,500 V	5,000 V	14,500 V
Removing bubble pack from PCB	7,000 V	20,000 V	26,500 V
Packing PCBs in foam-lined box	5,000 V	11,000 V	21,000 V

These are then multi-packaged inside plastic tubes, trays, or Styrofoam.

**NOTE:** 700 volts can degrade a product.

## Preventing electrostatic damage to equipment

Many electronic components are sensitive to ESD. Circuitry design and structure determine the degree of sensitivity. The following packaging and grounding precautions are necessary to prevent damage to electric components and accessories.

- To avoid hand contact, transport products in static-safe containers such as tubes, bags, or boxes.
- Protect all electrostatic parts and assemblies with conductive or approved containers or packaging.
- Keep electrostatic sensitive parts in their containers until they arrive at static-free stations.
- Place items on a grounded surface before removing them from their container.
- Always be properly grounded when touching a sensitive component or assembly.
- Avoid contact with pins, leads, or circuitry.
- Place reusable electrostatic-sensitive parts from assemblies in protective packaging or conductive foam.

## Personal grounding methods and equipment

Use the following equipment to prevent static electricity damage to equipment:

- **Wrist straps** are flexible straps with a maximum of one-megohm  $\pm$  10% resistance in the ground cords. To provide proper ground, a strap must be worn snug against bare skin. The ground cord must be connected and fit snugly into the banana plug connector on the grounding mat or workstation.
- **Heel straps/Toe straps/Boot straps** can be used at standing workstations and are compatible with most types of shoes or boots. On conductive floors or dissipative floor mats, use them on both feet with a maximum of one-megohm  $\pm$  10% resistance between the operator and ground.

Static Shielding Protection Levels	
Method	Voltage
Antistatic plastic	1,500
Carbon-loaded plastic	7,500
Metallized laminate	15,000

## Grounding the work area

To prevent static damage at the work area, use the following precautions:

- Cover the work surface with approved static-dissipative material. Provide a wrist strap connected to the work surface and properly grounded tools and equipment.
- Use static-dissipative mats, foot straps, or air ionizers to give added protection.
- Handle electrostatic sensitive components, parts, and assemblies by the case or PCB laminate. Handle them only at static-free work areas.
- Turn off power and input signals before inserting and removing connectors or test equipment.
- Use fixtures made of static-safe materials when fixtures must directly contact dissipative surfaces.
- Keep work area free of nonconductive materials such as ordinary plastic assembly aids and Styrofoam.
- Use field service tools, such as cutters, screwdrivers, and vacuums, that are conductive.

## Recommended materials and equipment

Materials and equipment that are recommended for use in preventing static electricity include:

- Antistatic tape
- Antistatic smocks, aprons, or sleeve protectors
- Conductive bins and other assembly or soldering aids
- Conductive foam
- Conductive tabletop workstations with ground cord of one-megohm +/- 10% resistance
- Static-dissipative table or floor mats with hard tie to ground
- Field service kits
- Static awareness labels
- Wrist straps and footwear straps providing one-megohm +/- 10% resistance
- Material handling packages
- Conductive plastic bags
- Conductive plastic tubes
- Conductive tote boxes
- Opaque shielding bags
- Transparent metallized shielding bags
- Transparent shielding tubes

## Routine care and maintenance

This chapter describes how to clean the computer, monitor, keyboard, and mouse of your retail point of sales system. Dust and other particles can accumulate on or inside the computer and accessories. These particles can scratch hardware components and can cause overheating, shortening the life of the computer. Cleaning the computer removes this potentially damaging buildup and helps prolong the life of the computer. HP recommends that you inspect your system for cleanliness once a month as part of a regular maintenance program.

### Drivers and firmware

HP recommends that you regularly download and install the latest drivers and firmware updates to help enhance computer performance, resolve known issues, and avoid replacing parts unnecessarily.

Please go to <http://www.hp.com/support> to download and install the latest drivers and BIOS updates for your specific Retail Point of Sale model.

### Operating guidelines

Follow these guidelines to prevent overheating and to help prolong the life of the computer:

- Keep the computer away from excessive moisture, direct sunlight, and extremes of heat and cold.
- Place the computer on a sturdy, level surface.
- Leave an area at least 10.2 cm (4 in) wide all around the computer and above the monitor clear to permit the flow of air in and out of the computer.

- Do not operate the computer with the cover or side panel removed.
- Do not stack computers on top of each other or place computers so near one another that they are subject to each other's re-circulated or preheated air.
- If you are operating the computer within a separate enclosure, the enclosure must have intake and exhaust ventilation. The same operating guidelines listed previously still apply.
- Keep liquids away from the computer and keyboard.
- Do not block or cover any intake and exhaust vents, this restrict the airflow into the computer.
- Do not place the keyboard, with the keyboard feet down, directly against the front of the computer as this also restricts airflow.
- Occasionally, clean the air vents. Lint, dust, and other foreign matter can block the vents and limit the airflow. Be sure to unplug the computer before cleaning the air vents.
- Install or enable power management functions of the operating system or other software, including sleep states

## Environmental specifications

This table describes the average environmental conditions for Retail Systems.

Specification	Description
Temperature	Operating: 10° to 40°C (50° to 104°F) Non-operating: -22° to 149° F (-30° to 65° C)
Relative humidity	Operating: 20% to 85% Non-operating: 0% to 95% (non-condensing at ambient)
Maximum altitude (unpressurized)	Operating: 3048 m (10,000 ft) Non-operating: 9144 m (30,000 ft)

Please visit <http://h10025.www1.hp.com/ewfrf/wc/siteHome?lc=en&cc=us> to view the specifications for other retail platform models.

## Before you begin

Before you begin cleaning the computer and components, perform these steps to reduce the risk of electrical shock:

1. Turn off the computer and monitor.
2. Unplug the power cord from the computer and monitor.

## Cleaning the computer case

Follow these steps to clean the computer case.

1. Use a clean, dry cloth to dust the computer case.
2. Use a clean, lint-free cloth or swab dampened with water to remove light stains or dirt.



**NOTE:** For stubborn stains, use isopropyl (rubbing) alcohol. You do not need to rinse the case afterwards as the alcohol evaporates quickly and does not leave a residue.



3. Wipe the computer with a clean, lint-free cloth.
4. Use a battery-powered vacuum to remove dust and buildup from the vents.

## Cleaning the monitor or touch screen

Follow these steps to clean the monitor or touch screen.

---

 **CAUTION:** Do not clean the monitor using the following chemicals and materials:

- Petroleum based materials such as benzene or thinner
- Alcohol (ethyl, methyl, or isopropyl)
- Abrasive material
- Any volatile substance

- 
1. Spray a small amount of a mild glass cleaner onto a lint-free soft cloth.
  2. Wipe the surface and each side of the display to remove any dirt, fingerprints, or other debris.

---

 **CAUTION:** Avoid wiping in the top corners where the optics are located.

3. Use a dry, soft, lint-free cloth to wipe the screen dry after cleaning.
4. Clean the display cabinet using a clean soft cloth that is lightly dampened with a mild detergent.

## Cleaning I/O ports and fan area

The computer has a series of ports, usually in the back. Dust and debris can collect in these ports, this can reduce connectivity and performance. Use a battery-powered vacuum to remove any debris that has accumulated in and around these ports.

---

 **NOTE:** Unplug the computer before cleaning the I/O ports and fan.

## Cleaning the keyboard

Follow these steps to clean the keyboard.

---

 **CAUTION:** Use safety glasses equipped with side shields before cleaning debris from under the keys.

1. Disconnect the keyboard from the computer.
2. Use a battery-powered vacuum to gently remove debris particles that get between and beneath the keyboard keys. Use a low setting to avoid removing key caps and springs.

You can also use canned, pressurized air to clean debris from under the keys.

---

 **CAUTION:** Too much air pressure can dislodge lubricants applied under the wide keys.

3. Use a clean, dry cloth and isopropyl alcohol to clean the buildup on the keyboard keys.

## Cleaning the mouse

Follow these steps to clean an optical mouse.

1. Unplug the mouse from the computer.
2. Wipe the body of the mouse with cleaning wipes or a cloth and cleanser.

3. Turn the mouse body upside down.
4. Clean the LED bulb and the surrounding area on the bottom of the mouse with a cotton swab dampened with isopropyl alcohol.

## Cleaning the MSR

Swipe a standard cleaning card through the MSR a couple of times to clean the MSR (magnetic strip reader). You can order a standard cleaning card online. Alternately, you can create a cleaning card by putting a thin, oil free cloth around a credit card.

## Service considerations

Listed below are some of the considerations that you should keep in mind during the disassembly and assembly of the computer.

### Power supply fan

The power supply fan is a variable-speed fan based on the temperature in the power supply.

---

**⚠ CAUTION:** The cooling fan is always on when the computer is in the “On” mode. The cooling fan is off when the computer is in “Standby,” “Suspend,” or “Off” modes.

You must disconnect the power cord from the power source before opening the computer to prevent system board or component damage.

---

## Tools and software Requirements

To service the computer, you need the following:

- Torx T-15 screwdriver
- Flat-bladed screwdriver (may sometimes be used in place of the Torx screwdriver)
- Phillips #2 screwdriver
- Diagnostics software
- Tamper-resistant T-15 wrench

## Screws

The screws used in the computer are not interchangeable. They may have standard or metric threads and may be of different lengths. If an incorrect screw is used during the reassembly process, it can damage the unit. HP strongly recommends that all screws removed during disassembly be kept with the part that was removed, then returned to their proper locations.

---

**⚠ CAUTION:** Metric screws have a black finish. U.S. screws have a silver finish and are used on hard drives only.

**CAUTION:** As each subassembly is removed from the computer, it should be placed away from the work area to prevent damage.

---

## Cables and connectors

Most cables used throughout the unit are flat, flexible cables. These cables must be handled with care to avoid damage. Apply only the tension required to seat or unseat the cables during insertion or removal from the connector. Handle cables by the connector whenever possible. In all cases, avoid bending or twisting the

cables, and ensure that the cables are routed in such a way that they cannot be caught or snagged by parts being removed or replaced.

---

 **CAUTION:** When servicing this computer, ensure that cables are placed in their proper location during the reassembly process. Improper cable placement can damage the computer.

---

## Hard Drives

Handle hard drives as delicate, precision components, avoiding all physical shock and vibration. This applies to failed drives as well as replacement spares.

- If a drive must be mailed, place the drive in a bubble-pack mailer or other suitable protective packaging and label the package “Fragile: Handle With Care.”
- Do not remove hard drives from the shipping package for storage. Keep hard drives in their protective packaging until they are actually mounted in the computer.
- Avoid dropping drives from any height onto any surface.
- If you are inserting or removing a hard drive, turn off the computer. Do not remove a hard drive while the computer is on or in standby mode.
- Before handling a drive, ensure that you are discharged of static electricity. While handling a drive, avoid touching the connector.
- Do not use excessive force when inserting a drive.
- Avoid exposing a hard drive to liquids, temperature extremes, or products that have magnetic fields such as monitors or speakers.

## Lithium coin cell battery

The battery that comes with the computer provides power to the real-time clock and has a minimum lifetime of about three years.

See the appropriate removal and replacement chapter for the chassis you are working on in this guide for instructions on the replacement procedures.

---

 **WARNING!** This computer contains a lithium battery. There is a risk of fire and chemical burn if the battery is handled improperly. Do not disassemble, crush, puncture, short external contacts, dispose in water or fire, or expose it to temperatures higher than 140°F (60°C). Do not attempt to recharge the battery.

 **NOTE:** Batteries, battery packs, and accumulators should not be disposed of together with the general household waste. In order to forward them to recycling or proper disposal, please use the public collection system or return them to HP, their authorized partners, or their agents.

---

## SATA hard drives

---

Serial ATA Hard Drive Characteristics	
Number of pins/conductors in data cable	7/7
Number of pins in power cable	15
Maximum data cable length	39.37 in (100 cm)
Data interface voltage differential	400-700 mV
Drive voltages	3.3 V, 5 V, 12 V

---

Serial ATA Hard Drive Characteristics	
Jumpers for configuring drive	N/A
Data transfer rate	6.0 Gb/s

## SATA hard drive cables

### SATA data cable

Always use an HP approved SATA 6.0 Gb/s cable as it is fully backwards compatible with the SATA 1.5 Gb/s drives.

Current HP desktop products ship with SATA 6.0 Gb/s hard drives.

SATA data cables are susceptible to damage if overflexed. Never crease a SATA data cable and never bend it tighter than a 30 mm (1.18 in) radius.

The SATA data cable is a thin, 7-pin cable designed to transmit data for only a single drive.

## SMART ATA drives

The Self Monitoring Analysis and Recording Technology (SMART) ATA drives for the HP Personal Computers have built-in drive failure prediction that warns the user or network administrator of an impending failure or crash of the hard drive. The SMART drive tracks fault prediction and failure indication parameters such as reallocated sector count, spin retry count, and calibration retry count. If the drive determines that a failure is imminent, it generates a fault alert.

## Cable management

Always follow good cable management practices when working inside the computer.

- Keep cables away from major heat sources like the heat sink.
- Do not jam cables on top of expansion cards or memory modules. Printed circuit cards like these are not designed to take excessive pressure on them.
- Keep cables clear of sliding or moveable parts to prevent them from being cut or crimped when the parts are moved.
- When folding a flat ribbon cable, never fold to a sharp crease. Sharp creases may damage the wires.
- Some flat ribbon cables come prefolded. Never change the folds on these cables.
- Do not bend any cable sharply. A sharp bend can break the internal wires.
- Never bend a SATA data cable tighter than a 30 mm (1.18 in) radius.
- Never crease a SATA data cable.
- Do not rely on components like the drive cage, power supply, or computer cover to push cables down into the chassis. Always position the cables to lay properly by themselves.

---

## 4 Removal and replacement procedures

---

 **NOTE:** HP continually improves and changes product parts. For complete and current information on supported parts for your computer, go to <http://partsurfer.hp.com>, select your country or region, and then follow the on-screen instructions.

---

Adherence to the procedures and precautions described in this chapter is essential for proper service. After completing all necessary removal and replacement procedures, run the Diagnostics utility to verify that all components operate properly.

---

 **NOTE:** Not all features listed in this guide are available on all computers.

---

### Preparation for disassembly

See [Routine care, SATA drive guidelines, and disassembly preparation on page 11](#) for initial safety procedures.

1. Remove/disengage any security devices that prohibit opening the computer.
2. Shut down the computer properly through the operating system, then turn off any external devices.
3. Disconnect the power cord from the power outlet.

---

 **CAUTION:** Regardless of the power-on state, voltage is always present on the system board as long as the system is plugged into an active AC outlet. You must disconnect the power cord and wait approximately 30 seconds for the power to drain to avoid damage to the internal components of the computer.

---

4. Disconnect all cables from the rear I/O connectors.

---

 **CAUTION:** The screws used in the computer are of different thread sizes and lengths; using the wrong screw in an application may damage the unit.

---

 **NOTE:** During disassembly, label each cable as you remove it, noting its position and routing. Keep all screws with the units removed.

---

## Installing a port cover

To install the port cover, snap the port cover onto the rear panel over the ports **(1)** and secure it with the screw **(2)**.



## Removing and attaching the ergonomic and compact stands

The RP9 can be attached to a wall, swing arm, pole-mounted bracket, or other mounting fixture by removing the stand (when ordered attached to the system unit). The RP9 supports the VESA industry standard 100 mm spacing between mounting holes.

This apparatus is intended to be supported by UL or CSA Listed wall mount bracket. HP recommends that you use an HP Quick Release mounting bracket for wall mounting (part number EM870AA).

---

**⚠ CAUTION:** To attach a third-party mounting solution to the RP9, four 4 mm, 0.7 pitch, and 10 mm long screws are required. Longer screws must not be used because they may damage the system. It is important to verify that the manufacturer's mounting solution is compliant with the VESA standard and is rated to support the weight of the system.

---

Follow the steps below to remove the stand, mount the RP9 to a wall mount or swing arm, and to install the stand.

1. Prepare the computer for disassembly ([Preparation for disassembly on page 19](#)).
2. To remove the ergonomic stand, lay the RP9 face down on a flat surface covered by a soft clean cloth. Push up the release latch on the rear of the display head **(1)**, tilt the stand back **(2)**, and then lift up from the display **(3)**.

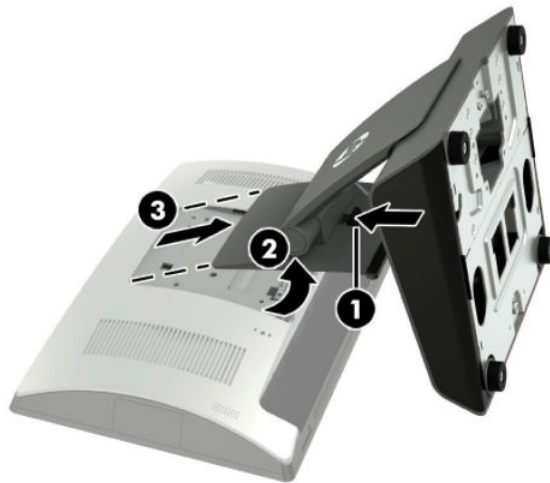

3. To remove the compact stand, lay the RP9 face down on a flat surface covered by a soft clean cloth. Push up the release latch on the rear of the display head (1), tilt the stand back (2), and then lift up from the display (3).



4. To mount the display head to a wall or swing arm, use the 100 mm x 100 mm VESA mounting holes on the rear of the display head.

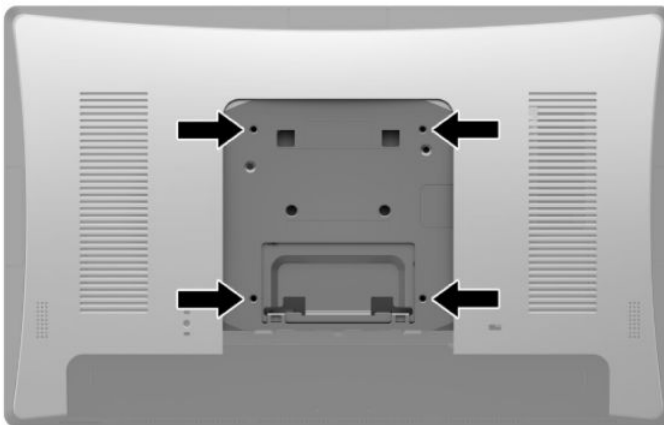



5. To attach the ergonomic stand, lay the RP9 face down on a flat surface covered by a soft clean cloth. Slide the tabs on the top of the stand mount into the slots on the display head **(1)**, and then rotate the bottom of the stand mount down onto the display head so that it snaps in place **(2)**.



6. To attach the compact stand, lay the RP9 face down on a flat surface covered by a soft clean cloth. Slide the tabs on the top of the stand mount into the slots on the display head **(1)**, and then rotate the bottom of the stand mount down onto the display head so that it snaps in place **(2)**.



## Routing cables (ergonomic stand)

To route cables through the ergonomic stand:

1. Prepare the computer for disassembly ([Preparation for disassembly on page 19](#)).
2. Connect the cables to the appropriate rear connectors.



---

**NOTE:** Tilt the display head back for easy access to the rear connectors.

---

3. Route the cables from the connectors on the rear panel through the cable retainer on the neck of the stand **(1)**, and then through the hole in the center of the base and out the underside of the base **(2)**.

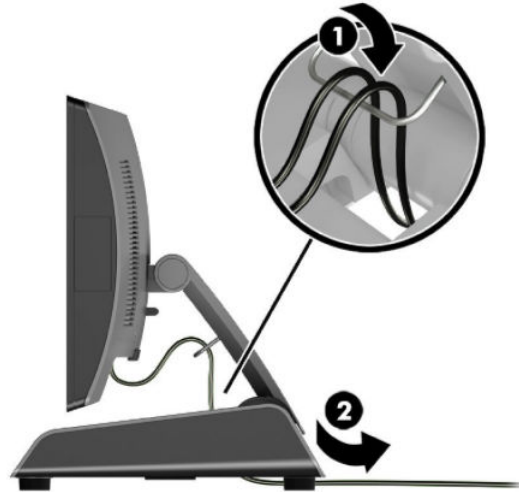

4. Reconnect the power cord and press the power button.

## Routing cables (compact stand)

To route cables through the compact stand:

1. Prepare the computer for disassembly ([Preparation for disassembly on page 19](#)).
2. Connect the cables to the appropriate rear connectors.



---

**NOTE:** Tilt the display head back for easy access to the rear connectors.

---

3. Snap off the cable routing cover on the neck of the stand **(1)**.
4. Route the cables from the connectors on the rear panel down the neck of the stand, and then through the hole in the center of the base and out the underside of the base **(2)**.

5. Snap the cable routing cover onto the neck of the stand to cover the cables **(3)**.



6. Reconnect the power cord and press the power button.

## Removing and replacing the power supply (ergonomic stand)

Description
Power supply, 230W, standard
Power supply, 230W, slim

To remove and replace the power supply:

1. Prepare the computer for disassembly ([Preparation for disassembly on page 19](#)).
2. Unplug the DC power cable from the connector on the rear of the display head.
3. Pull up on the center of the cover on the right side of the base and rotate the cover upward.

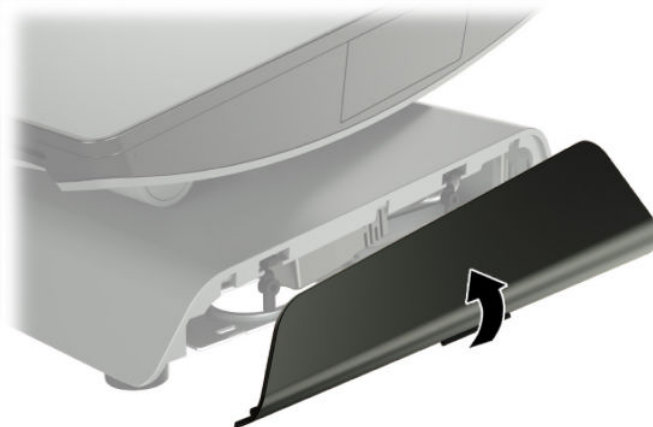

4. Pull up on the center of the cover on the left side of the base and rotate the cover upward.



5. Lay the RP9 face down on a flat surface covered by a soft clean cloth. Lift the pull tab and loosen the screw on the bottom plate of the stand (1), then lift the bottom of the plate up (2), and then pull the plate off the stand (3).

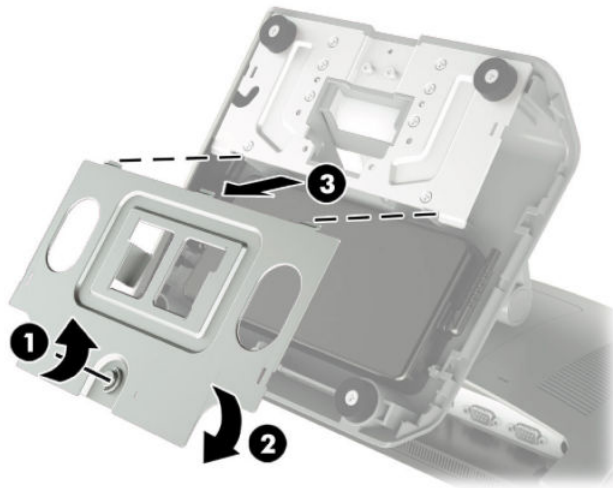

6. Unplug the AC power cord from the side of the power supply (1), and then lift the power supply out of the stand's base (2).



7. Route the fixed side of the new power supply's power cord through the hole in the center of the base and connect it to the DC power connector on the rear panel (1). Place the new power supply into the stand's base (2), and then connect the AC power cord to the side of the power supply (3) and route the cord through the retainer slot on the base.



8. Reassemble the stand.

## Rear cover and shield

To remove the rear cover and shield:

1. Prepare the computer for disassembly ([Preparation for disassembly on page 19](#))
2. Press the two rear cover latches outward **(1)**. Slide the rear cover up, and then lift it off the display head **(2)**.

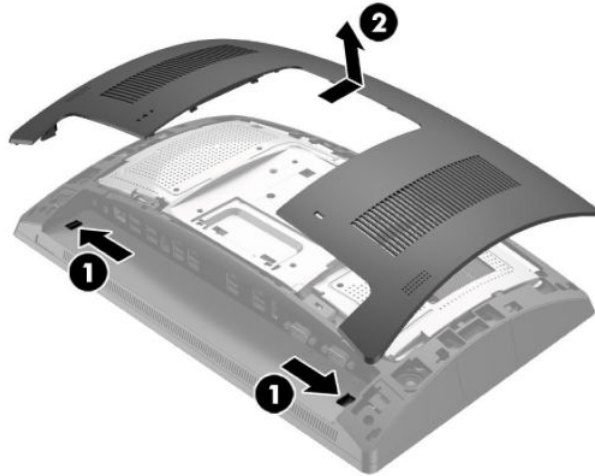

3. Use the finger slots on the rear metal shield to pull the top of the shield up, and then lift the shield off the display head.



To install a rear cover and shield, reverse the removal procedures.

## Installing an optional HP integrated USB barcode scanner, magnetic strip reader (MSR), biometric reader, or webcam

Only install HP approved integrated USB modules designed for these USB ports. The USB ports do not support optical drives or hard drives.

The integrated barcode scanner, integrated MSR, and integrated biometric reader can be installed on the left or right side of the display head. The integrated webcam can only be installed on the top of the display head. There is a separate integrated barcode scanner that can be installed on the bottom of the display head.

### Installing an optional HP integrated USB module on the sides or top of the display head

The procedure for installing a module is the same for all modules, whether it is on the left side, the right side, or the top of the display head.

1. Prepare the computer for disassembly ([Preparation for disassembly on page 19](#)).
2. Remove the rear cover ([Rear cover and shield on page 28](#)).
3. Remove the two screws that secure the port cover (1), and then pull the port cover off the display head (2).

---

 **NOTE:** You may need to gently loosen the port cover from inside of the screw holes with a flat screwdriver.

---

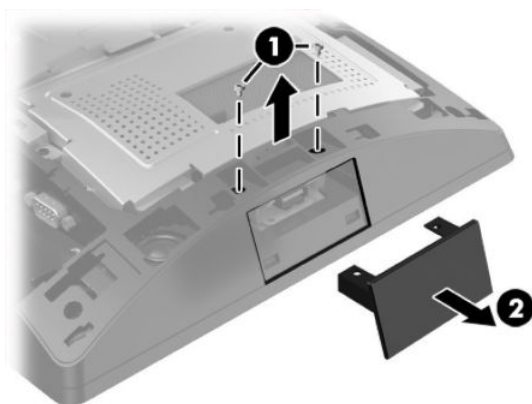

4. Insert the USB connector on the module into the USB port **(1)**, and then secure the module with the two screws that were previously removed **(2)**.

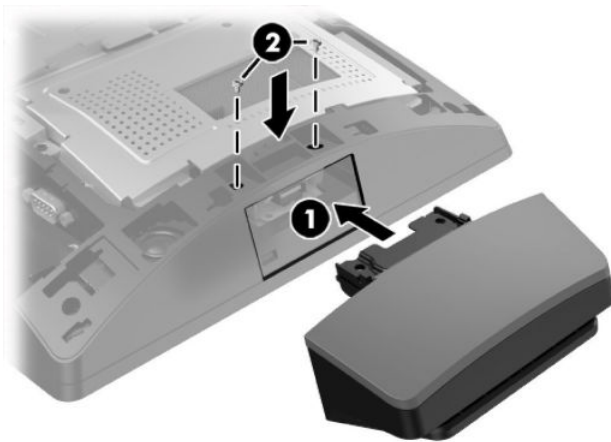

5. Reassemble the computer.

If you install a new MSR, it needs to be configured with the system settings using HP USB Mini Magnetic Stripe Reader (MSR) Configuration Software. Use the following procedure to configure the new CSR.

1. Connect the old MSR (the one being replaced).
2. Start HP magnetic stripe reader configuration utility ([http://h20564.www2.hp.com/hpsc/swd/public/detail?swItemId=ir\\_125989\\_1&swEnvOid=4047](http://h20564.www2.hp.com/hpsc/swd/public/detail?swItemId=ir_125989_1&swEnvOid=4047)).
3. Retrieve the configuration details from the old MSR and save.
4. Connect the new MSR (the replacement).
5. Write the saved configuration to the new MSR.



## Installing an optional HP integrated USB barcode scanner on the bottom of the display head

To install an integrated USB barcode scanner:

1. Prepare the computer for disassembly ([Preparation for disassembly on page 19](#)).
2. Slide the cover on the barcode scanner down and then lift the cover up to remove it **(1)**. Plug the barcode scanner into the rear I/O Powered USB 12V (B) connector **(2)**, and then secure the barcode scanner with the screw provided **(3)**. Replace the barcode scanner cover **(4)**.

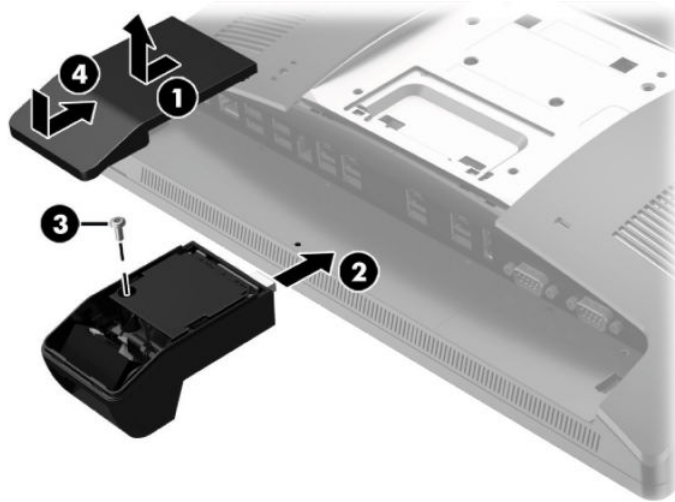

3. Reconnect all cables to the rear I/O connectors.
4. Reconnect the power cord and press the power button.

## Installing a 2 x 20 LCD or 7” LCD customer facing display (CFD)

A short extension arm CFD can be attached to the top of the display head or a long extension arm CFD can be attached to the bottom of the stand's base. The procedure for installing a CFD is the same, whether it is a 2 x 20 or 7” LCD.

### Installing a top mount CFD

To install a top mount CFD:

1. Prepare the computer for disassembly ([Preparation for disassembly on page 19](#)).
2. Remove the rear cover ([Rear cover and shield on page 28](#)).
3. Remove the two screws that secure the top port cover (1), and then pull the port cover off the display head (2).

---

 **NOTE:** You may need to gently loosen the port cover from inside of the screw holes with a flat screwdriver.

---

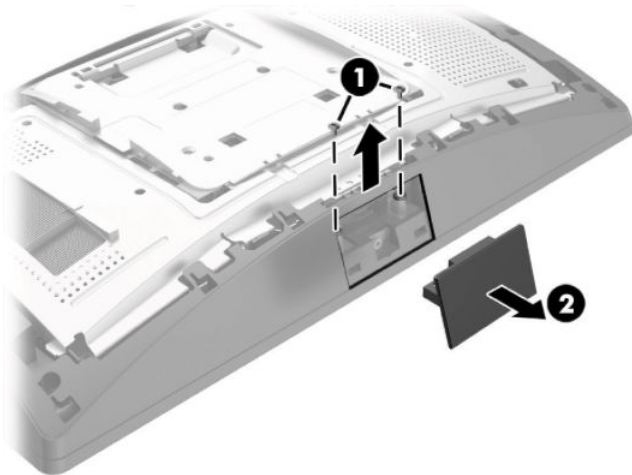

4. Align the tabs on the rear cover with the slots on the display head while placing the cover on the display head, and then slide the cover down so that it snaps in place.

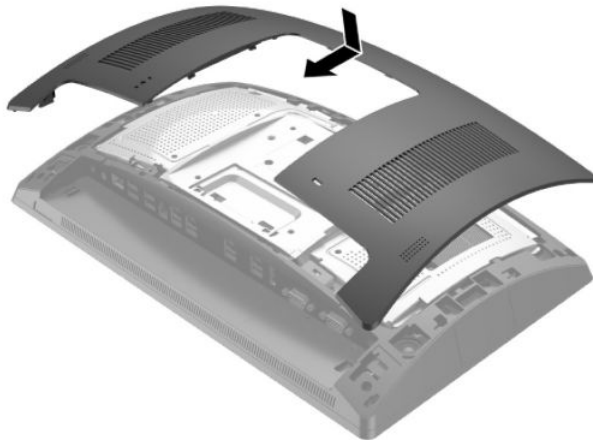

5. Remove the cover from the CFD arm by pulling back the top of the cover **(1)** and then the bottom of the cover. Insert the USB connector on the CFD into the USB port **(2)**, and then secure the CFD with the screw provided **(3)**. Replace the arm cover **(4)** by snapping on the top of the cover and then the bottom of the cover.



6. Reconnect all cables to the rear I/O connectors.
7. Reconnect the power cord and press the power button.

## Installing a bottom mount CFD

To install a bottom mount CFD:

1. Prepare the computer for disassembly ([Preparation for disassembly on page 19](#)).
2. Unplug the power cable from the connector on the rear of the display head.
3. Lay the RP9 face down on a flat surface covered by a soft clean cloth.
4. Slide the CFD bracket onto the underside of the base **(1)**, and then secure the bracket with the screw **(2)**.

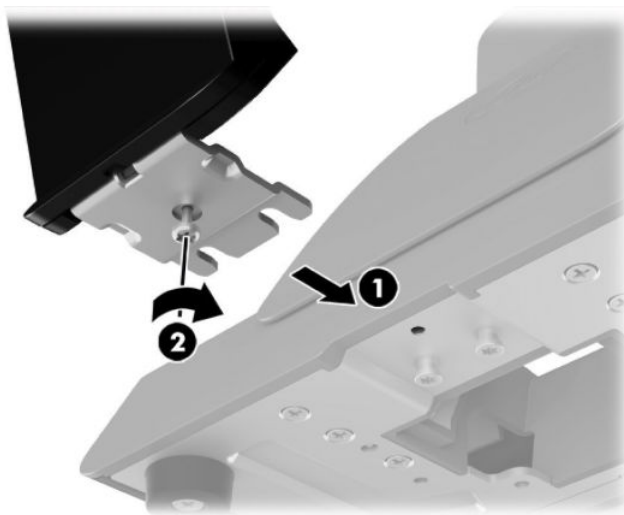

5. Route the CFD cable up through the center hole in the base and connect it to a USB port on the rear I/O.

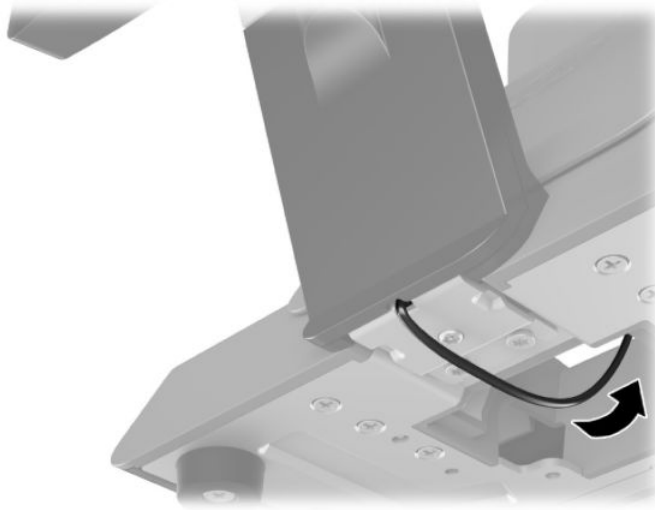

6. Reconnect the power cord and press the power button.

# Installing memory

Description
Memory modules (SODIMM, PC4-17000, CL15)
16 GB
8 GB
4 GB

The computer comes with at least one preinstalled double data rate 4 synchronous dynamic random access memory (DDR4-SDRAM) small outline dual inline memory module (SODIMM). There are two memory sockets on the system board that can be populated with up to 32GB of memory.

## DDR4-SDRAM SODIMMs

For proper system operation, the SODIMMs must be:

- industry-standard 260-pin
- unbuffered non-ECC PC4-17000 DDR4-2133 MHz-compliant
- 1.2 volt DDR4-SDRAM SODIMMs

The SODIMMs must also:

- support CAS latency 15 DDR4 2133 MHz (15-15-15 timing)
- contain the mandatory Joint Electronic Device Engineering Council (JEDEC) specification

In addition, the computer supports:

- 512-Mbit, 1-Gbit, 2-Gbit, 4-Gbit, and 8-Gbit non-ECC memory technologies
- single-sided and double-sided SODIMMs
- The following SODIMMs are offered:
  - 4GB DDR4-2133 SODIMM (1 x 4GB) RAM
  - 8GB DDR4-2133 SODIMM (2 x 4GB) RAM
  - 8GB DDR4-2133 SODIMM (1 x 8GB) RAM
  - 16GB DDR4-2133 SODIMM (1 x 16GB) RAM
  - 16GB DDR4-2133 SODIMM (2 x 8GB) RAM
  - 32GB DDR4-2133 SODIMM (2 x 16GB) RAM

 **NOTE:** The system will not operate properly if you install unsupported SODIMMs.

## Removing and installing a SODIMM

**⚠ CAUTION:** You must disconnect the power cord and wait approximately 30 seconds for the power to drain before replacing the memory module. Regardless of the power-on state, voltage is always supplied to the memory module as long as the computer is plugged into an active AC outlet. Adding or removing the memory module while voltage is present may cause irreparable damage to the memory module or system board.

The memory module socket has gold-plated metal contacts. When upgrading the memory, it is important to use a memory module with gold-plated metal contacts to prevent corrosion and/or oxidation resulting from having incompatible metals in contact with each other.

Static electricity can damage the electronic components of the computer or optional cards. Before beginning these procedures, ensure that you are discharged of static electricity by briefly touching a grounded metal object. For more information, refer to [Electrostatic discharge information on page 11](#).

When handling a memory module, be careful not to touch any of the contacts. Doing so may damage the module.

To remove and install a memory module:

1. Prepare the computer for disassembly ([Preparation for disassembly on page 19](#)).
2. Remove the rear cover and shield ([Rear cover and shield on page 28](#)).
3. To remove a SODIMM, press outward on the two latches on each side of the SODIMM **(1)**, and then pull the SODIMM out of the socket **(2)**.



4. To install a SODIMM, slide the new SODIMM into the socket at approximately a 30° angle **(1)**, and then press the SODIMM down into the socket **(2)** so that the latches lock it in place.



**📝 NOTE:** A memory module can be installed in only one way. Match the notch on the module with the tab on the memory socket.

5. Reassemble the computer.

The computer automatically recognizes the additional memory when you turn on the computer.

# Removing and installing a 2.5-inch hard drive

---

**Description**

---

1 TB, hybrid SSD, hard drive

500 GB, 7200 rpm, 2.5-inch, self-encrypting hard drive

500 GB, 7200 rpm, 2.5-inch hard drive

---

**⚠ CAUTION:** If you are replacing a hard drive, be sure to back up the data from the old drive so that you can transfer the data to the new drive.

---

To remove and install a 2.5-inch hard drive:

1. Prepare the computer for disassembly ([Preparation for disassembly on page 19](#)).
2. Remove the rear cover and shield ([Rear cover and shield on page 28](#)).
3. Disconnect the cable from the rear of the drive **(1)**, pull the arm back at the rear of the drive **(2)**, and then slide the drive back and lift it out of the drive bay **(3)**.

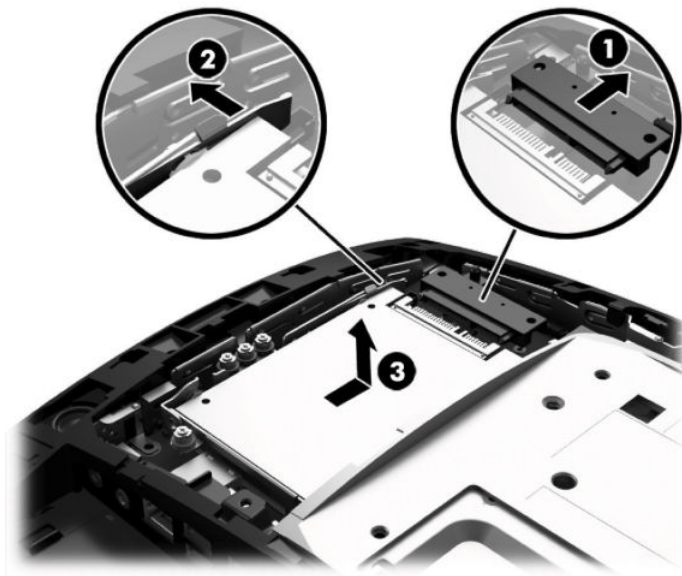

4. If replacing the drive, remove the four mounting screws from the drive and install them in the new drive.

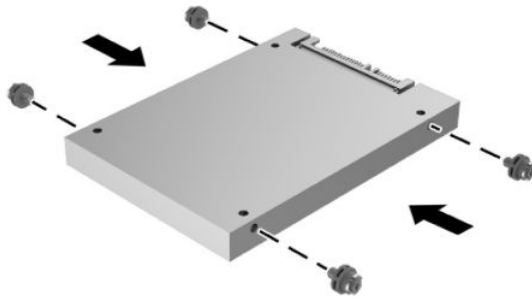

 **NOTE:** If you need mounting screws for the drive, four extra mounting screws are installed on the drive bay frame.

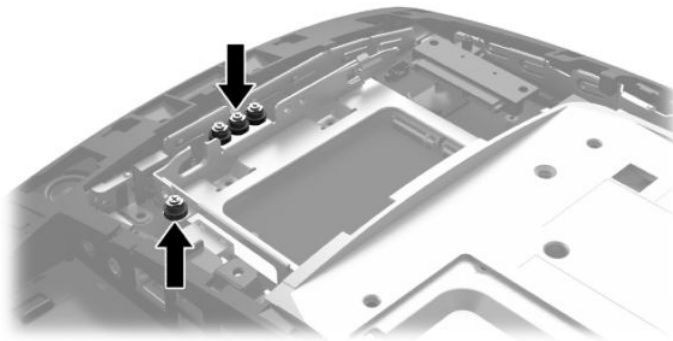

5. Place the drive down into the drive bay, slide the drive forward (1), and then connect the cable to the rear of the drive (2).

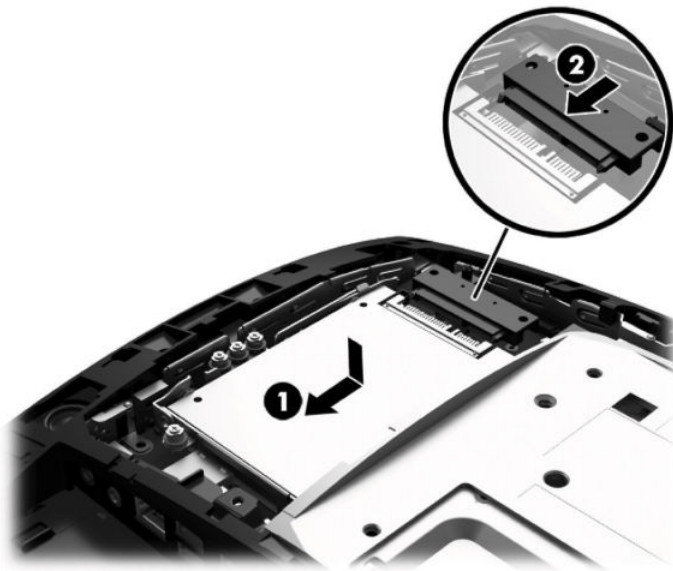

6. Reassemble the computer.



# Removing and installing an M.2 storage device

Description
256 GB Solid-state drive
128 GB Solid-state drive
128 GB Solid-state drive, self-encrypting (SED)
120 GB Solid-state drive
64-GB, flash, MLC

There are two M.2 storage device connectors located under the 2.5-inch drive bay.

To remove and install an M.2 storage device:

1. Prepare the computer for disassembly ([Preparation for disassembly on page 19](#)).
2. Remove the rear cover and shield ([Rear cover and shield on page 28](#)).
3. Remove the 2.5-inch hard drive, if installed ([Removing and installing a 2.5-inch hard drive on page 37](#)).
4. Remove the screw that secures the device to the system board **(1)** so that the end pops up **(2)**, and then slide the device out of the connector **(3)**.

 **NOTE:** Due to the small size of the screw, a magnetized screwdriver may be helpful to remove the screw.

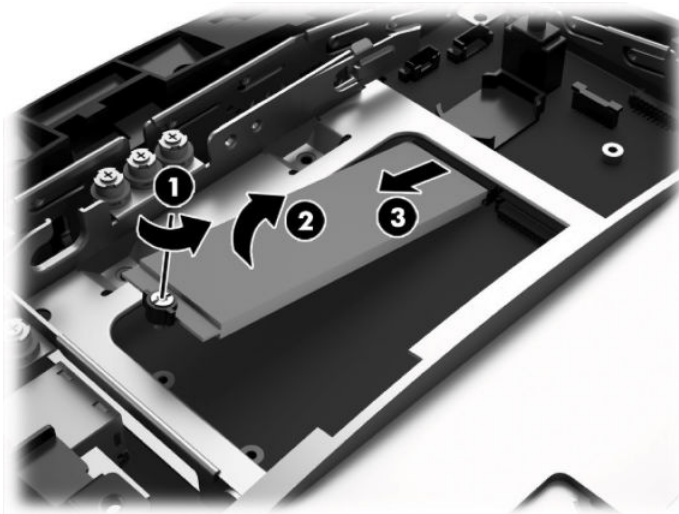

5. To install an M.2 storage device, slide the pins on the storage device into the system board connector while holding the device at approximately a 30° angle **(1)**. Rotate the other end of the device down **(2)**, and then secure the device with the screw that was either previously removed or preinstalled in the screw hole **(3)**.

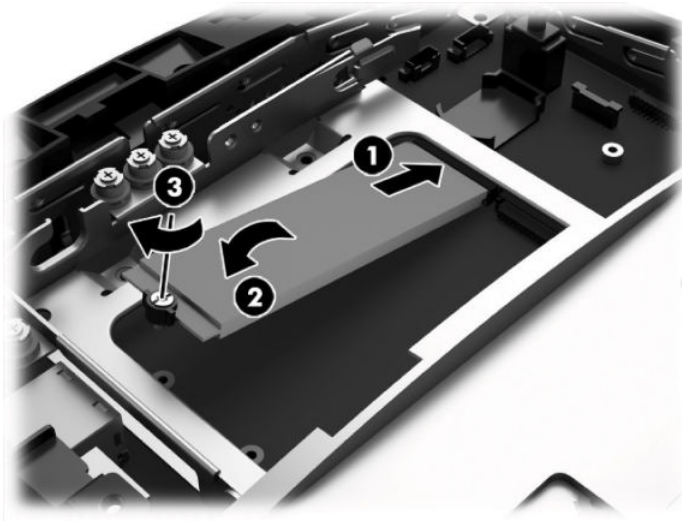

6. Reassemble the computer.

# Replacing the battery

The battery that comes with the computer provides power to the real-time clock. When replacing the battery, use a battery equivalent to the battery originally installed in the computer. The computer comes with a 3-volt lithium coin cell battery.

**⚠ WARNING!** The computer contains an internal lithium manganese dioxide battery. There is a risk of fire and burns if the battery is not handled properly. To reduce the risk of personal injury:

Do not attempt to recharge the battery.

Do not expose to temperatures higher than 60°C (140°F).

Do not disassemble, crush, puncture, short external contacts, or dispose of in fire or water.

Replace the battery only with the HP spare designated for this product.

**⚠ CAUTION:** Before replacing the battery, it is important to back up the computer CMOS settings. When the battery is removed or replaced, the CMOS settings will be cleared.

Static electricity can damage the electronic components of the computer or optional equipment. Before beginning these procedures, ensure that you are discharged of static electricity by briefly touching a grounded metal object.

**📝 NOTE:** The lifetime of the lithium battery can be extended by plugging the computer into a live AC wall socket. The lithium battery is only used when the computer is NOT connected to AC power.

HP encourages customers to recycle used electronic hardware, HP original print cartridges, and rechargeable batteries. For more information about recycling programs, go to <http://www.hp.com/recycle>.

To replace the battery:

1. Prepare the computer for disassembly ([Preparation for disassembly on page 19](#)).
2. Remove the rear cover and shield ([Rear cover and shield on page 28](#)).
3. To release the battery from its holder, squeeze the metal clamp that extends above one edge of the battery. When the battery pops up, lift it out **(1)**.
4. To insert the new battery, slide one edge of the replacement battery under the lip of the holder with the positive side up. Push the other edge down until the clamp snaps over the other edge of the battery **(2)**.

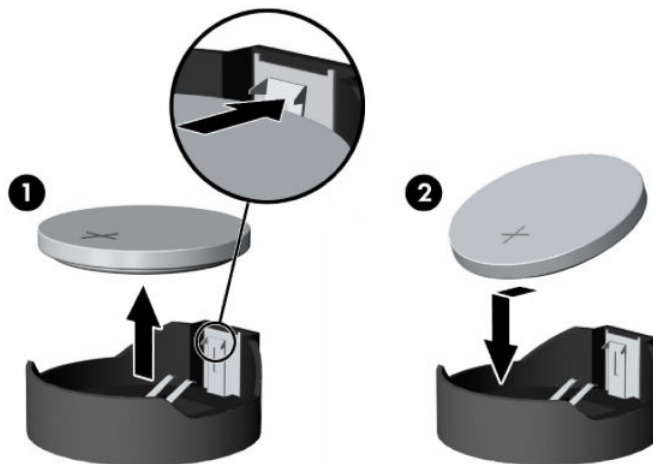

5. Reassemble the computer.

# WLAN module

---

**Description**

---

802.11 a/b/g/n + Bluetooth 4.0, 2x2

802.11 a/b/g/n + Bluetooth 4.0, 2x2 (for use only in Indonesia)

Intel Dual Band Wireless-AC 8260

---

The WLAN module is secured with one screw and has two connected antennas.

To remove the WLAN module:

1. Prepare the computer for disassembly ([Preparation for disassembly on page 19](#))
2. Remove the rear cover and shield ([Rear cover and shield on page 28](#)).
3. Disconnect the antenna cables from the module **(1)**.
4. Remove the Phillips screw **(2)** that secures the module to the system board.
5. Lift the module to a 45-degree angle, and then pull it away to remove it from the socket **(3)**.

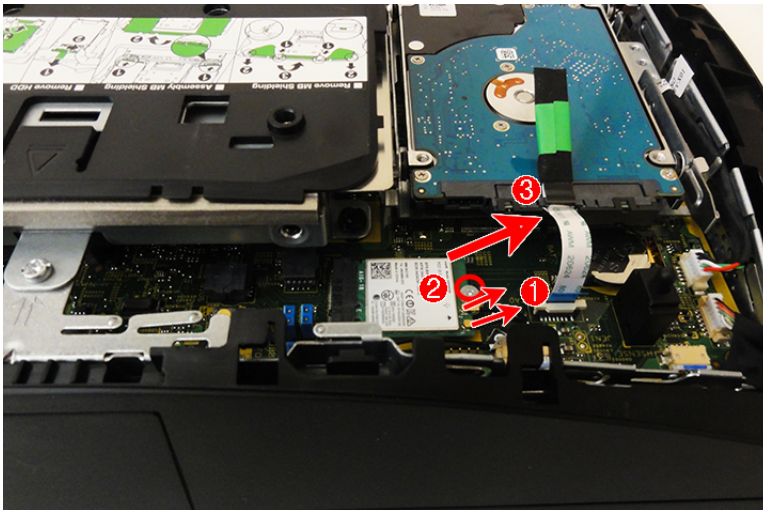

To install a WLAN module, reverse the removal procedures.

## Hard drive bracket

The hard drive bracket is secured with two Torx screws. You must remove it to remove the VESA mount bracket.

To remove the hard drive bracket:

1. Prepare the computer for disassembly ([Preparation for disassembly on page 19](#)).
2. Remove the rear cover and shield ([Rear cover and shield on page 28](#)).
3. Remove the 2.5-inch hard drive, if installed ([Removing and installing a 2.5-inch hard drive on page 37](#)).
4. Remove the two Torx screws **(1)** that secure the bracket to the computer.
5. Lift the hard drive bracket out of the computer **(2)**.

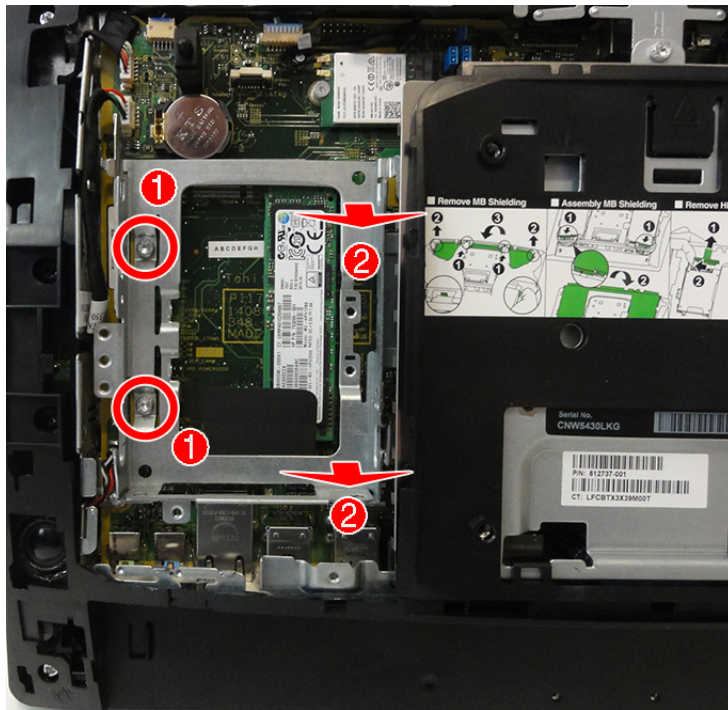

To reinstall the hard drive bracket, reverse the removal procedure.

## VESA mount bracket

The VESA mount bracket has a plastic cover. The bracket is secured with five Torx screws. You must remove the hard drive bracket to remove the VESA mount bracket.

To remove the VESA mount bracket:

1. Prepare the computer for disassembly ([Preparation for disassembly on page 19](#)).
2. Remove the rear cover and shield ([Rear cover and shield on page 28](#)).
3. Remove the 2.5-inch hard drive, if installed ([Removing and installing a 2.5-inch hard drive on page 37](#)).
4. Remove the hard drive bracket ([Hard drive bracket on page 43](#)).
5. Remove the plastic VESA cover by pressing the tab **(1)**, and then sliding the cover up and off the VESA bracket **(2)**.

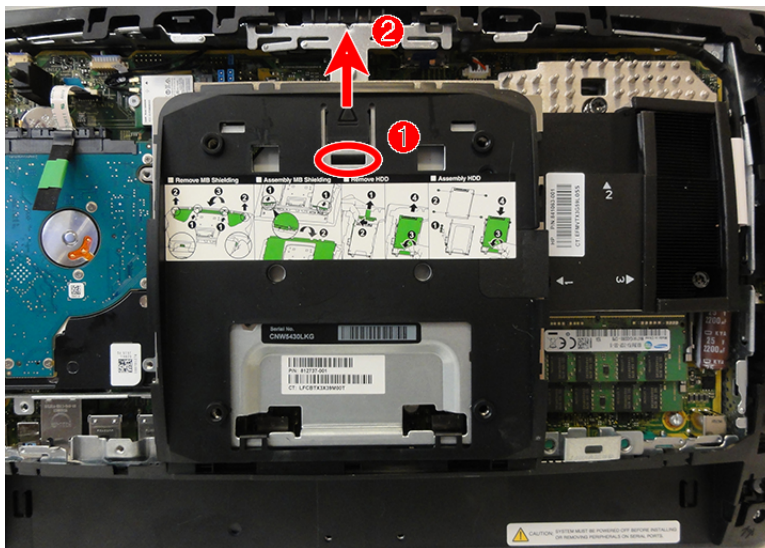

6. Remove the four black Torx screws **(1)** and one silver Torx screw **(2)** that secures the VESA mount bracket to the computer.
7. Disconnect the fan cable from the system board **(3)**.



**NOTE:** The fan is housed under and secured to the under side of the VESA mount bracket.

8. Lift the VESA mount bracket out of the computer **(4)**.

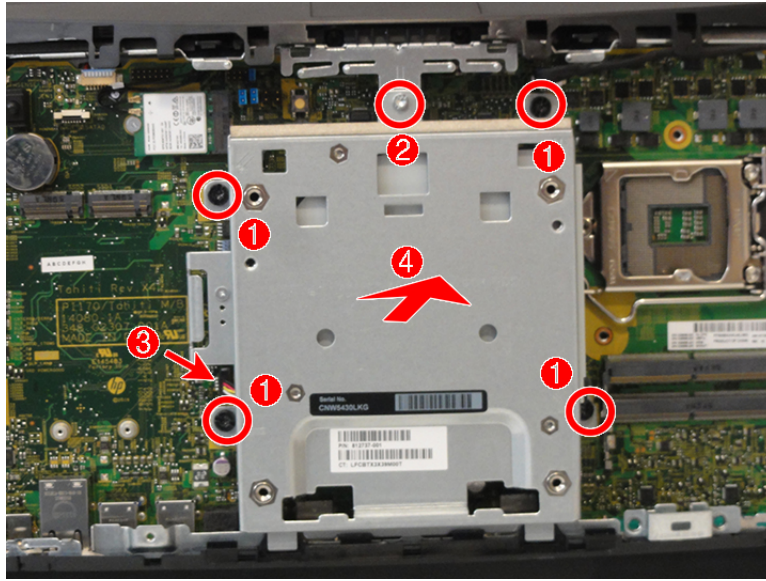

To reinstall the VESA bracket, reverse the removal procedure.

## Heat sink

The heat sink is secured to the system board. You must remove the plastic VESA cover from the VESA mount bracket to remove the heat sink.

To remove the heat sink:

1. Prepare the computer for disassembly ([Preparation for disassembly on page 19](#)).
2. Remove the rear cover and shield ([Rear cover and shield on page 28](#)).
3. Remove the plastic cover from atop the VESA mount bracket ([VESA mount bracket on page 44](#)).
4. In the order indicated on the heat sink, loosen the three captive Phillips screws that secure the heat sink to the system board.

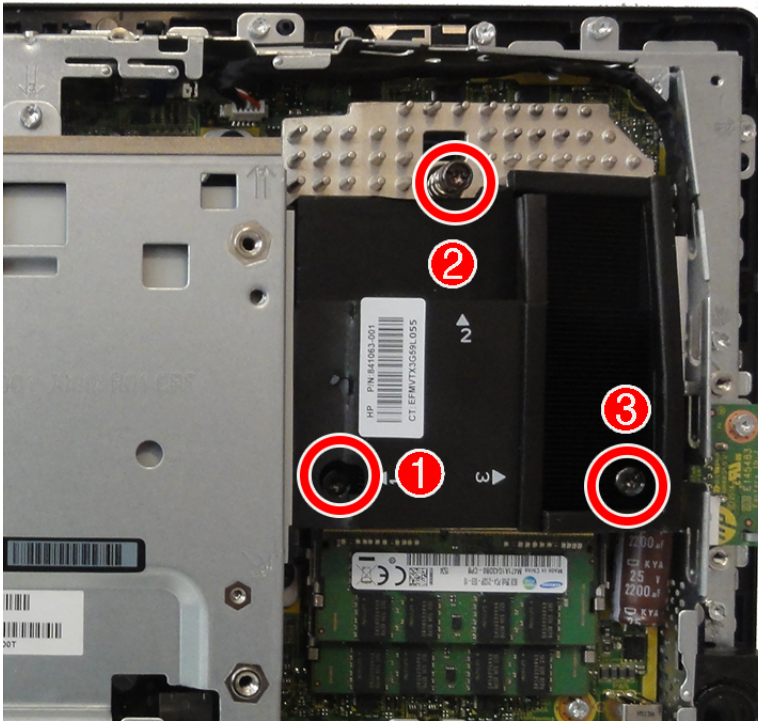

5. Lift the heat sink off the system board.

---

**⚠ CAUTION:** To reduce a degradation in thermal performance, be sure not to touch the thermal grease on the surface of the processor or the heat sink.

---

To replace the heat sink, reverse the removal procedures.



# Processor

The system board includes a standard Intel processor socket.

Description
Intel Core i7-6700
Intel Core i5-6500
Intel Core i3-6100
Intel Pentium G4400
Intel Celeron G3900

To remove the processor:

1. Prepare the computer for disassembly ([Preparation for disassembly on page 19](#)).
2. Remove the rear cover and shield ([Rear cover and shield on page 28](#)).
3. Remove the plastic cover from atop the VESA mount bracket ([VESA mount bracket on page 44](#)).
4. Remove the heat sink ([Heat sink on page 46](#)).
5. Rotate the locking lever to its full open position **(1)**.
6. Raise and rotate the microprocessor retainer to its fully open position **(2)**, and then carefully lift the processor from the socket **(3)**.

**CAUTION:** Do NOT handle the pins in the processor socket. These pins are very fragile and handling them could cause irreparable damage. Once pins are damaged it may be necessary to replace the system board.

The heat sink must be installed within 24 hours of installing the processor to prevent damage to the processor's solder connections.

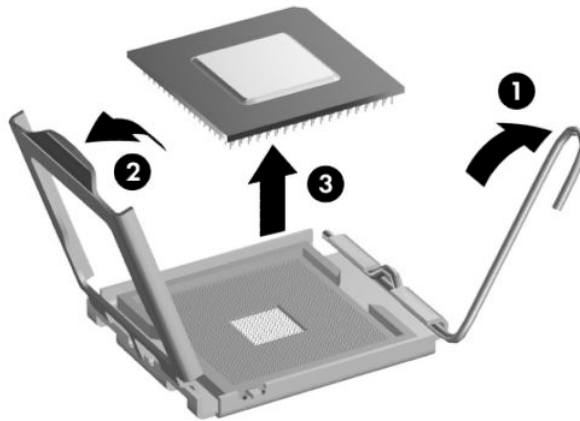

**NOTE:** After installing a new processor onto the system board, always update the system ROM to ensure that the latest version of the BIOS is being used on the computer. The latest system BIOS can be found on the Web at: <http://www.hp.com>.

## Fan

The fan is housed under and secured to the under side of the VESA mount bracket.

To remove the fan:

1. Prepare the computer for disassembly ([Preparation for disassembly on page 19](#)).
2. Remove the rear cover and shield ([Rear cover and shield on page 28](#)).
3. Remove the 2.5-inch hard drive, if installed ([Removing and installing a 2.5-inch hard drive on page 37](#)).
4. Remove the hard drive bracket ([Hard drive bracket on page 43](#)).
5. Remove the VESA mount bracket ([VESA mount bracket on page 44](#)).
6. Position the VESA mount bracket upside down.
7. Remove the three Torx screws **(1)** that secure the fan to the VESA mount bracket.
8. Remove the fan from the bracket **(2)**.

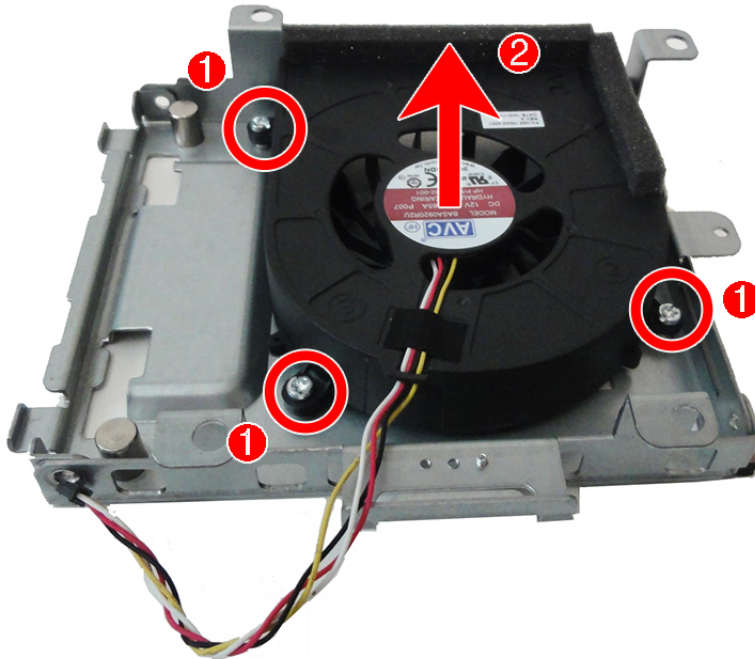

To reinstall the fan, reverse the removal procedure.

## Rear trim

The rear trim is secured with eight Torx screws.

To remove the rear trim:

1. Prepare the computer for disassembly ([Preparation for disassembly on page 19](#)).
2. Remove the rear cover and shield ([Rear cover and shield on page 28](#)).
3. Remove the four silver Torx screws **(1)** from each corner of the computer.
4. Remove the four black Torx screws **(2)** from each side of the computer.
5. Flex the top of the trim until it disengages from the computer, and then lift the trim from the computer **(3)**.

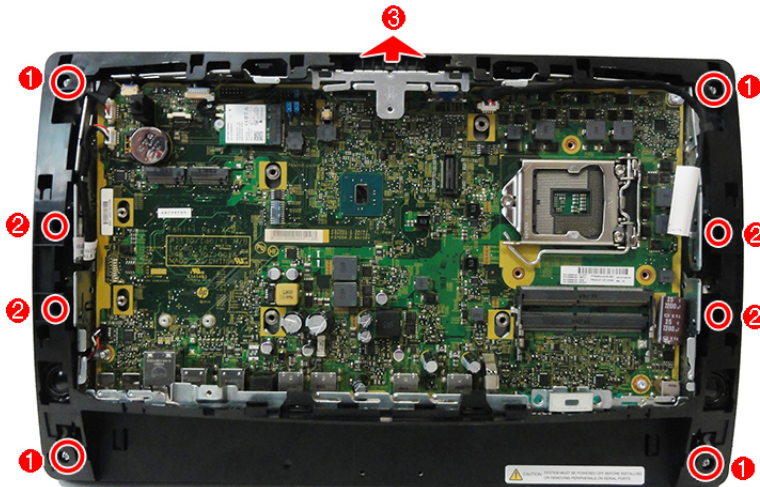

To reinstall the rear trim, reverse the removal procedure.

## USB port

There are removable USB ports on the left and right side of the computer. 18.5-inch models also include a USB ports at the top.

To remove a USB port:

1. Prepare the computer for disassembly ([Preparation for disassembly on page 19](#)).
2. Remove the rear cover and shield ([Rear cover and shield on page 28](#)).
3. Remove the rear trim ([Rear trim on page 49](#)).
4. Remove the screw from the USB board, and then rotate the board to access the connector underneath.

 **NOTE:** The following image shows the left and right USB ports on 15.6-inch models. 18.5-inch models also include a removable USB port at the top.

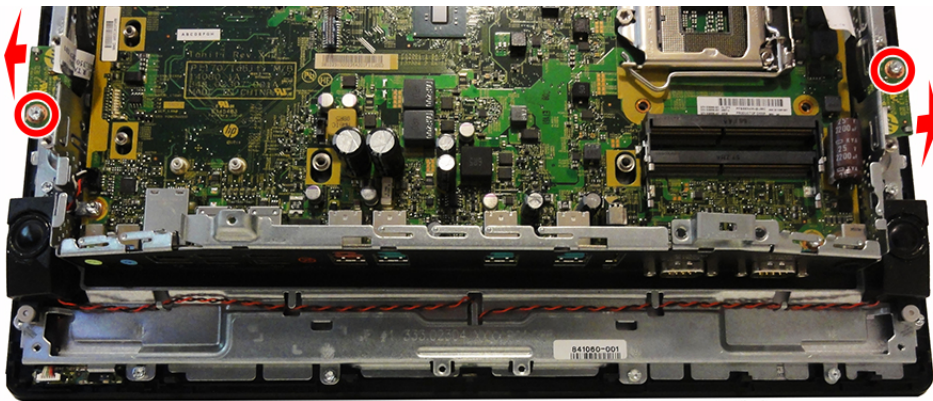

5. Disconnect the cable from the USB port.

 **NOTE:** The left USB port is shown in the following image.

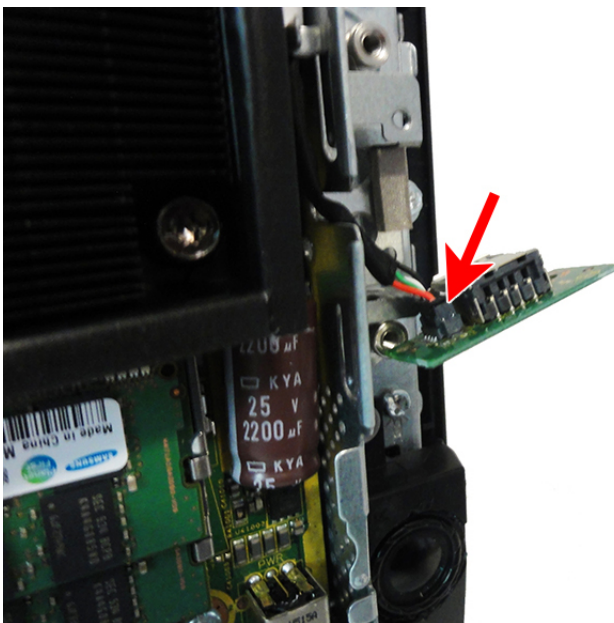

To install the USB port, reverse the removal procedures.

## Speakers

The computer uses two speakers located on the bottom left and right sides. The speakers are wired together and plug into one connector.

To remove the speakers:

1. Prepare the computer for disassembly ([Preparation for disassembly on page 19](#)).
2. Remove the rear cover and shield ([Rear cover and shield on page 28](#)).
3. Remove the rear plastic trim ([Rear trim on page 49](#)).
4. Lift the speakers off the computer. Speakers are held in place on posts.
5. Remove the speaker cables from the clips built into the bottom of the computer.

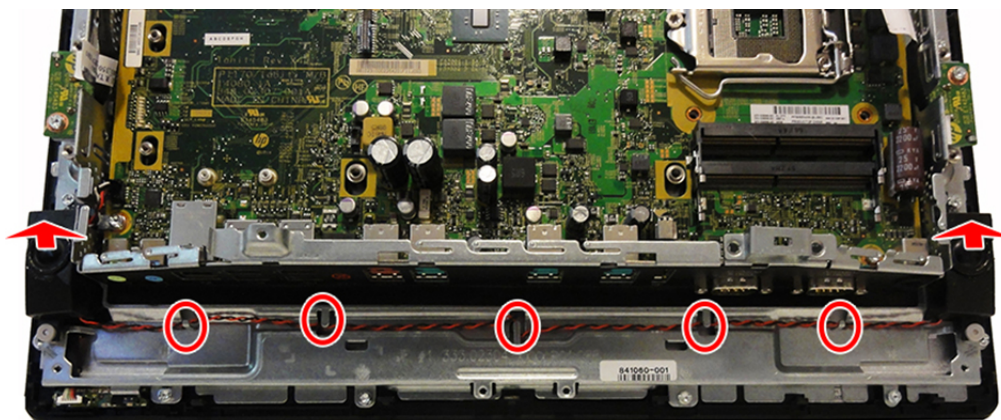

To replace the speakers, reverse the removal procedures.

## Antennas

The wireless antenna cables connect from the WLAN module to antennas at the top of the computer. Each antenna is secured with one screw and one clip.

To remove the antennas:

1. Prepare the computer for disassembly ([Preparation for disassembly on page 19](#)).
2. Remove the rear cover and shield ([Rear cover and shield on page 28](#)).
3. Remove the rear plastic trim ([Rear trim on page 49](#)).
4. Remove the Torx screw that secures each antenna to the computer **(1)**.
5. Rotate the antenna upward to remove them from the clips.
6. Pull the antenna cable through the routing hole in the top of the chassis **(2)**.

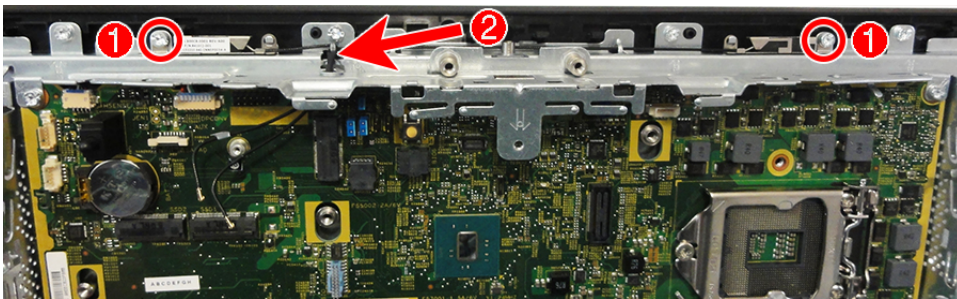

To reinstall the antennas, reverse the removal procedure.

# System board



**NOTE:** All system board spare part kits include replacement thermal material.

The system board is secured with five screws, four of which also secure removable brackets. You must remove the top and left brackets to remove the system board.

To remove the system board:

1. Prepare the computer for disassembly ([Preparation for disassembly on page 19](#)).
2. Remove the rear cover and shield ([Rear cover and shield on page 28](#)).
3. Remove the 2.5-inch hard drive, if installed ([Removing and installing a 2.5-inch hard drive on page 37](#)).
4. Remove the hard drive bracket ([Hard drive bracket on page 43](#)).
5. Remove the heat sink ([USB port on page 50](#)).
6. Remove the rear trim ([Rear trim on page 49](#)).
7. Remove the VESA mount bracket ([VESA mount bracket on page 44](#)).
8. Remove the right USB port ([USB port on page 50](#)). Note that this port is on the left side when looking at the rear of the computer.
9. Remove the right speaker ([Speakers on page 51](#)). Note that this speaker is on the left side when looking at the rear of the computer.
10. When replacing the system board, make sure the following components are removed from the defective system board and installed on the replacement system board:
  - Memory modules ([Installing memory on page 35](#))
  - M.2 storage device ([Removing and installing an M.2 storage device on page 39](#))
  - WLAN module ([WLAN module on page 42](#))
  - Processor ([Processor on page 47](#))
11. Remove the top bracket:
  - a. Remove the two Torx screws **(1)** that secure the top bracket to the chassis.

- b. Rotate the bracket up and off the computer **(2)**.

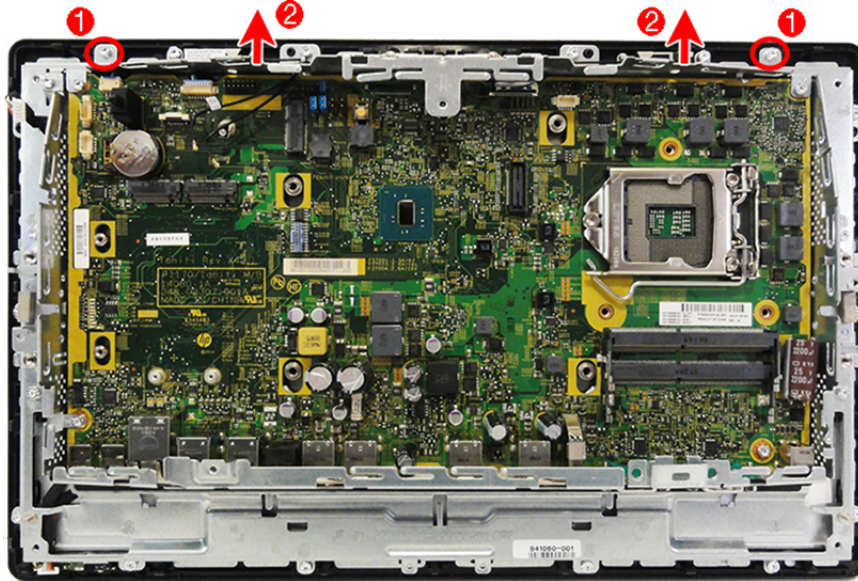

**12.** Remove the left bracket:

- a. Remove the two Torx screws **(1)** that secure the left bracket to the chassis.  
b. Rotate the bracket to the left and off the computer **(2)**.

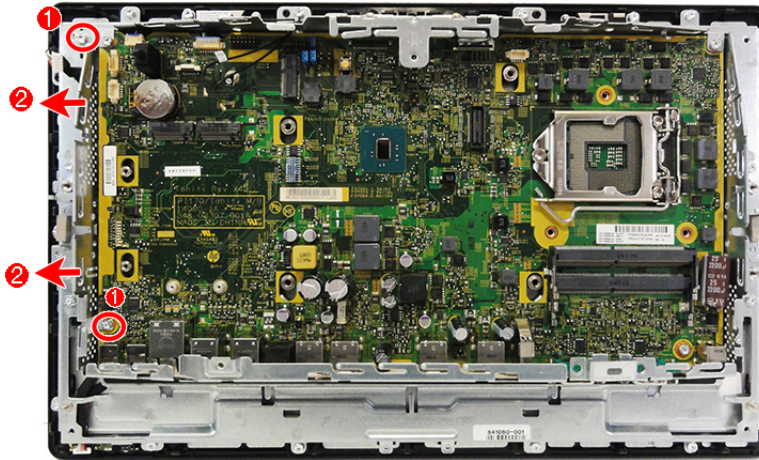

**13.** Disconnect the remaining cables from the system board:

- Power board
- Touch board
- Connector board
- WLAN antennas
- Display
- Left USB board



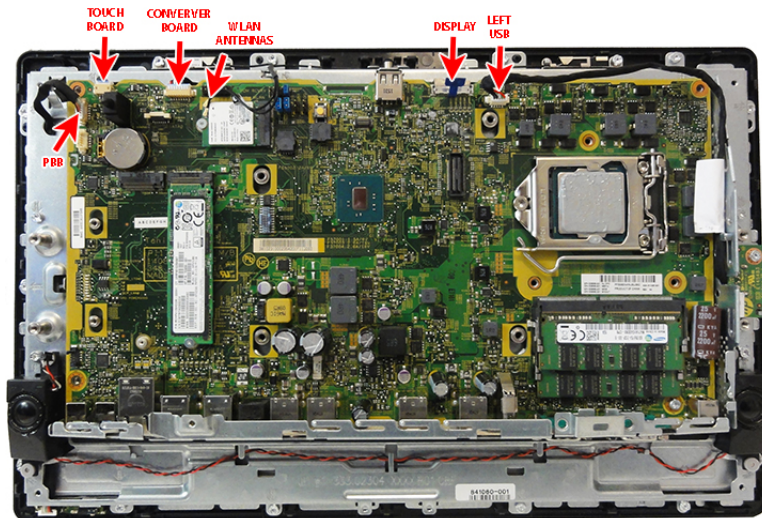

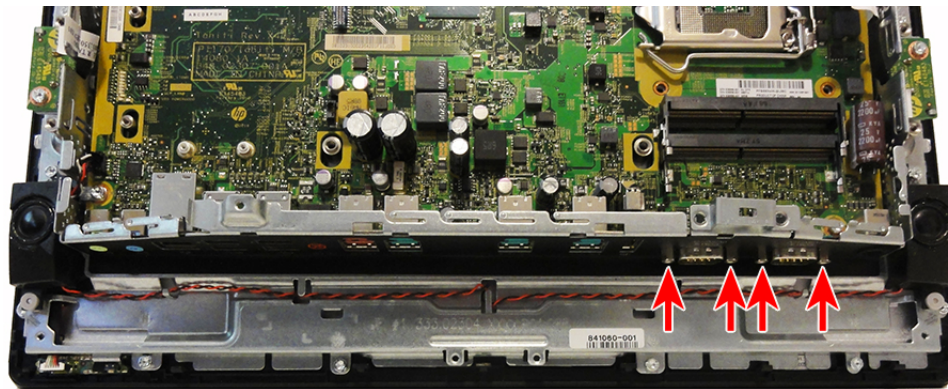

14. Remove the four nuts from the powered serial connectors at the bottom of the computer.

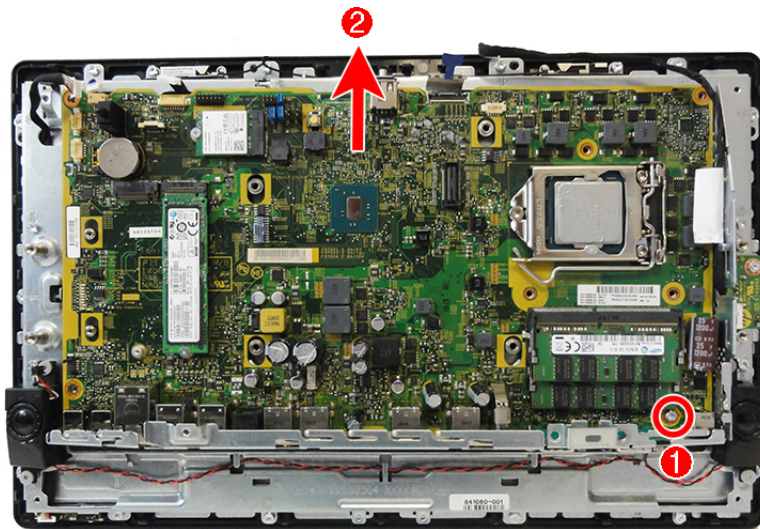

15. Remove the remaining Torx screw (1), and then pull the system board up and out of the computer (2).



To install the system board, reverse the removal procedures.

 **NOTE:** When replacing the system board, you must change the chassis serial number in the BIOS.

## System board callouts

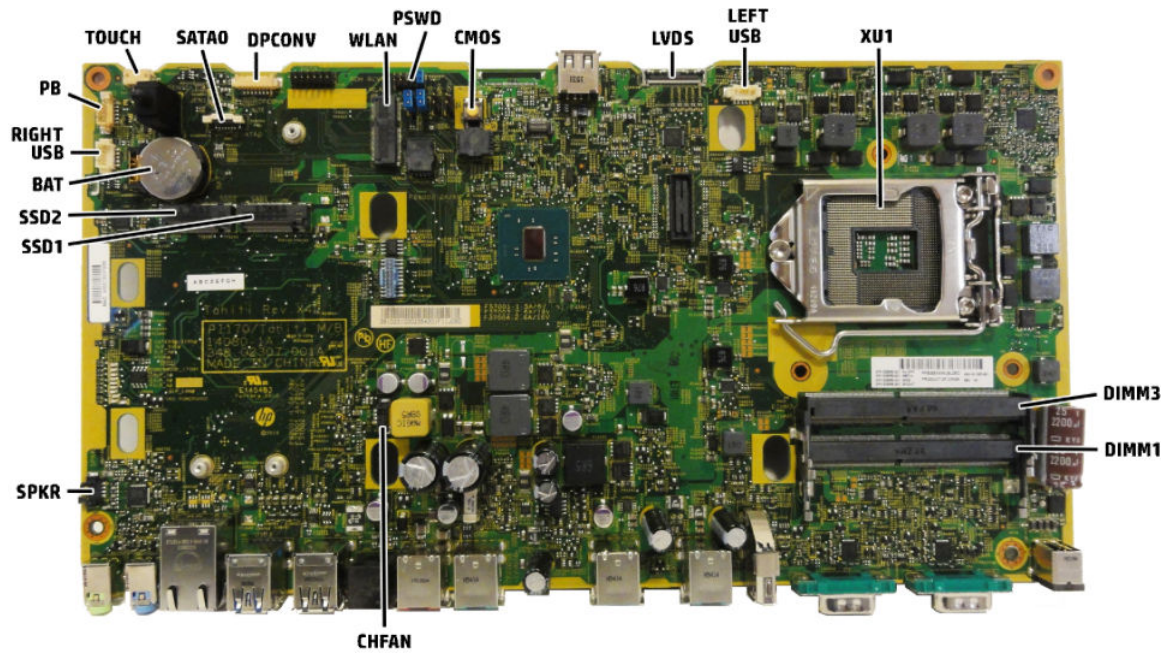

Sys Bd Label	Color	Component	Sys Bd Label	Color	Component
TOUCH	White	Touch board	DIMM3	Black	Memory module
SATA0	Black	Hard drive	DIMM1	Black	Memory module
DPCONV	White	Converter board	CHFAN	Black	Fan
WLAN	Black	WLAN module	SPKR	White	Speaker
PSWD	Blue	Clear system passwords	SSD1	Black	Solid-state drive
CMOS	Yellow	Reset CMOS	SSD2	Black	Solid-state drive
LVDS	Silver	Display connector	BAT	Black	RTC battery
LEFT USB	White	Left USB port	RIGHT USB	White	Right USB port
XU1	Silver	Processor	PB	White	Power board

# Display panel assembly

You can remove the display with most components installed.

**⚠ WARNING!** To reduce risk of personal injury from hot surfaces, allow the internal system components to cool before touching.

To remove the display assembly:

1. Prepare the computer for disassembly ([Preparation for disassembly on page 19](#)).
2. Remove the rear cover and shield ([Rear cover and shield on page 28](#)).
3. Remove the right USB port ([USB port on page 50](#)). Note that this port is on the left side when looking at the rear of the computer.
4. Remove the speakers ([Speakers on page 51](#)).
5. Remove the top system board bracket:
  - a. Remove the three Torx screws (1) that secure the top bracket to the chassis.
  - b. Rotate the bracket up and off the computer (2).

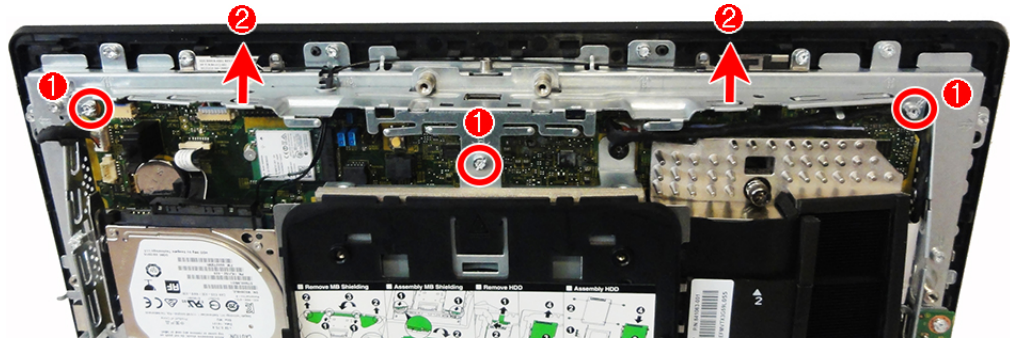

6. Remove the left bracket:
  - a. Remove the two Torx screws (1) that secure the left bracket to the chassis.
  - b. Rotate the bracket to the left and off the computer (2).

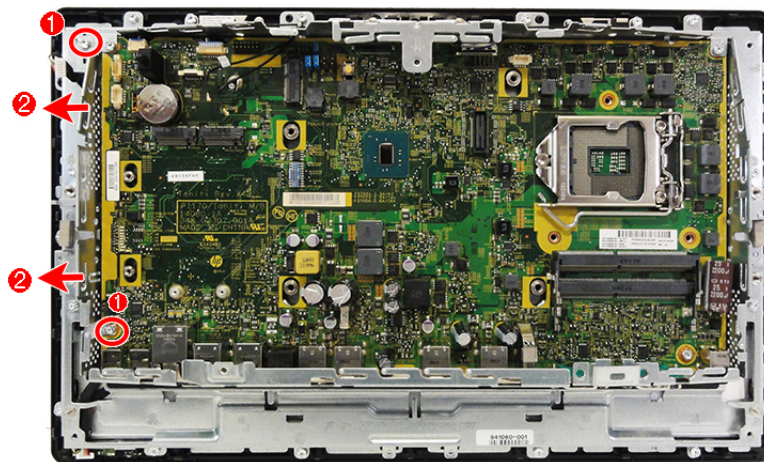

7. Disconnect the following cables from the system board:

- Power board
- Touch board
- Converter board
- Display

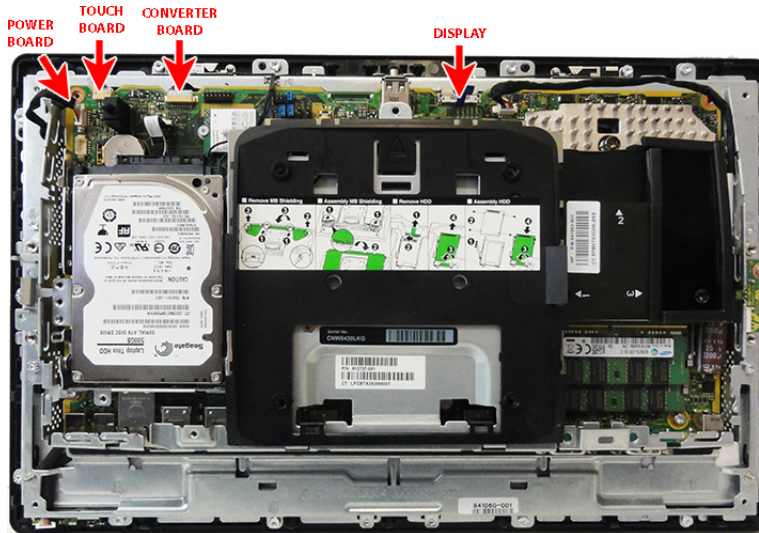

8. Remove the 18 Torx screws that secure the display panel assembly to the main computer bracket.

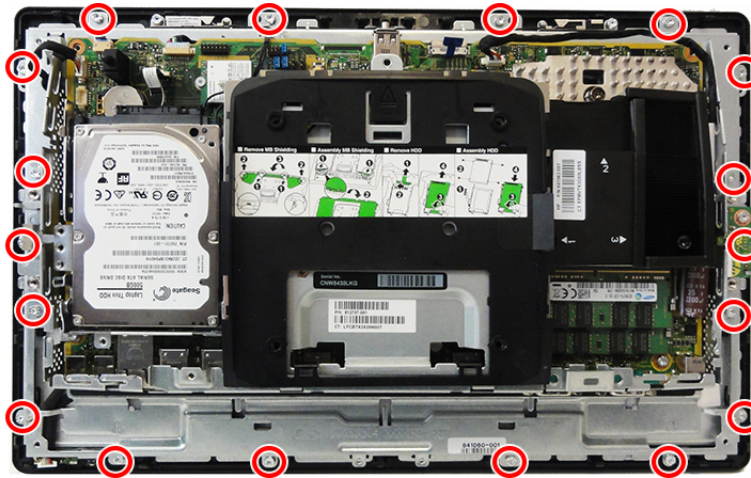

9. Lift the bracket off the display panel assembly.

To replace the display panel assembly, reverse the removal procedures.

## Power board

The power board is located at the bottom, left of the computer. You must remove the display to access the power board.

To remove the power board:

1. Prepare the computer for disassembly ([Preparation for disassembly on page 19](#)).
2. Remove the rear cover and shield ([Rear cover and shield on page 28](#)).
3. Remove the right USB port ([USB port on page 50](#)). Note that this port is on the left side when looking at the rear of the computer.
4. Remove the speakers ([Speakers on page 51](#)).
5. Remove the display ([Display panel assembly on page 57](#)).
6. Disconnect the cable from the board **(1)**.
7. Pull the tab that secures the right side of the board **(2)**.
8. Lift the board out of the computer **(3)**.

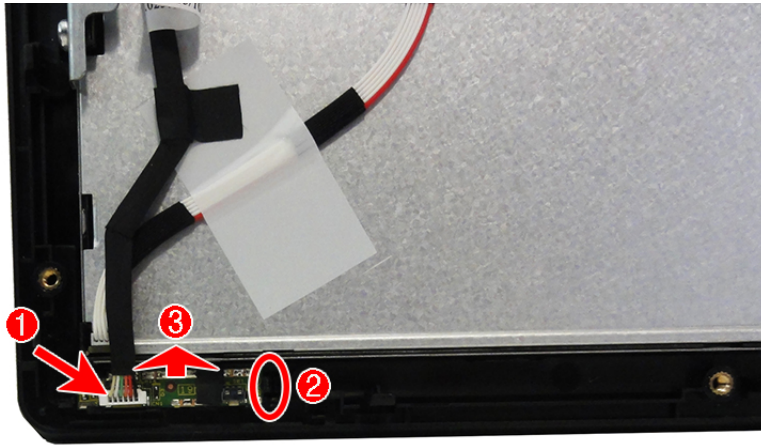

To reinstall the power board, reverse the removal procedure.

---

# 5 Configuring the software

## Touch screen calibration

HP recommends that you calibrate the touch screen before using the system to ensure that the touch point registers on the screen where the stylus or finger touches the screen. If at any time you find that the touch point is not registering properly, you may need to repeat the calibration process.

### Calibration for Windows 7 Professional and Embedded POSReady 7

To calibrate the touch module in Windows 7 Professional and Embedded POSReady 7:

1. Open the **Start** menu, tap the **Control Panel** link and type “calibrate” in the Search box. Under **Tablet PC Settings**, tap the **Calibrate the screen for pen or touch input** link. In the **Tablet PC Settings** dialog box, tap the **Calibrate** button, then proceed to step 2.
2. Follow the on-screen instructions to press the target marks on the touch screen. At the end of the calibration process, the touch module should be aligned with the video and the touch points will be accurate.

### Calibration for Windows 8.1 Professional and Embedded 8.1 Industry Pro Retail

To calibrate the touch module in Windows 8.1 Professional and Embedded 8.1 Industry Pro Retail:

1. Launch the Control Panel. You can type “Control Panel” in the Search box to access it.
2. In the Control Panel type “calibrate” in the Search box. Under **Tablet PC Settings**, tap the **Calibrate the screen for pen or touch input** link. In the **Tablet PC Settings** dialog box, tap the **Calibrate** button, then proceed to step 3.
3. Follow the on-screen instructions to press the target marks on the touch screen. At the end of the calibration process, the touch module should be aligned with the video and the touch points will be accurate.

### Calibration for Windows 10 Professional and Windows 10 IoT Enterprise for Retail

To calibrate the touch module in Windows 10 Professional and Windows 10 IoT Enterprise for Retail:

1. Launch the Control Panel. You can type “Control Panel” in the Search box to access it.
2. In the Control Panel type “calibrate” in the Search box. Under **Tablet PC Settings**, tap the **Calibrate the screen for pen or touch input** link. In the **Tablet PC Settings** dialog box, tap the **Calibrate** button, then proceed to step 3.
3. Follow the on-screen instructions to press the target marks on the touch screen. At the end of the calibration process, the touch module should be aligned with the video and the touch points will be accurate.

# Configuring all optional HP integrated USB peripheral modules (HP integrated USB barcode scanner, magnetic strip reader (MSR), biometric reader, or webcam)

To configure the integrated USB peripheral, refer to the *HP Point of Sale Configuration Guide* (available in English only). The guide is located with the documentation on your retail computer and at <http://www.hp.com/support>. To access the guide on the retail computer, select **Start > HP Point of Sale Information**.

---

 **NOTE:** Check <http://www.hp.com/support> for updated software or documentation that became available between the time your product was manufactured and the time it was delivered to you.

---

## Configuring powered serial ports

The serial ports can be configured as standard (non-powered) serial ports or powered serial ports. Some devices use a powered serial port. If the serial port is configured as a powered port, devices that support a powered serial interface do not require an external power source.

---

 **CAUTION:** The system must be powered off before connecting or disconnecting serial port devices.

 **NOTE:** The computer ships with all serial ports configured in standard non-powered serial mode (0 Volts) by default.

---

The serial ports can be configured using the Computer F10 Setup utility. Under the **Advanced > Port Options** menu, you are given the option to select the following three settings for each individual serial port.

- 0 Volts
- 5 Volts
- 12 Volts

---

 **CAUTION:** Unplug all devices currently connected to the powered serial ports and reboot the computer before changing the serial port voltage settings in the Computer F10 Setup utility.

 **NOTE:** To access the Computer F10 Setup utility, restart the computer and press the **F10** key as soon as the HP logo screen is displayed (before the computer boots to the operating system).

---

---

# 6 Computer Setup (F10) Utility

## Computer Setup (F10) Utilities

Use Computer Setup (F10) Utility to do the following:

- Change factory default settings.
- View the system configuration, including settings for processor, graphics, memory, audio, storage, communications, and input devices.
- Modify the boot order of bootable devices such as hard drives, optical drives, or USB flash media devices.
- Select Post Messages Enabled or Disabled to change the display status of Power-On Self-Test (POST) messages. Post Messages Disabled suppresses most POST messages, such as memory count, product name, and other non-error text messages. If a POST error occurs, the error is displayed regardless of the mode selected. To manually switch to Post Messages Enabled during POST, press any key (except **F1** through **F12**).
- Establish an Ownership Tag, the text of which is displayed each time the system is turned on or restarted.
- Enter the Asset Tag or property identification number assigned by the company to this computer.
- Enable the power-on password prompt during system restarts (warm boots) as well as during power-on.
- Establish a setup password that controls access to the Computer Setup (F10) Utility and the settings described in this section.
- Secure integrated I/O functionality, including the serial, USB, or parallel ports, audio, or embedded NIC, so that they cannot be used until they are unsecured.
- Enable or disable removable media boot ability.
- Solve system configuration errors detected but not automatically fixed during the Power-On Self-Test (POST).
- Replicate the system setup by saving system configuration information on a USB device and restoring it on one or more computers.
- Enable or disable DriveLock security (when supported by drive).

## Using Computer Setup (F10) Utilities

Computer Setup can be accessed only by turning the computer on or restarting the system. To access the Computer Setup Utilities menu, complete the following steps:

1. Turn on or restart the computer.
2. Repeatedly press **F10** when the monitor light turns green to access the utility.

You can also press **Esc** to a menu that allows you to access different options available at startup, including the Computer Setup utility.



**NOTE:** If you do not press **F10** at the appropriate time, you must restart the computer and again repeatedly press **F10** when the monitor light turns green to access the utility.

---



3. A choice of four headings appears in the Computer Setup Utilities menu: Main, Security, Advanced, and UEFI Drivers.



---

**NOTE:** Selecting UEFI Drivers restarts the computer into the 3rd party option ROM management application. You can access this application directly by pressing **F3** during startup.

---

4. Use the arrow (left and right) keys to select the appropriate heading. Use the arrow (up and down) keys to select the option you want, then press **Enter**. To return to the Computer Setup Utilities menu, press **Esc**.
5. To apply and save changes, select **Main > Save Changes and Exit**.
  - If you have made changes that you do not want applied, select **Ignore Changes and Exit**.
  - To reset to factory settings or previously saved default settings (some models), select **Apply Factory Defaults and Exit**. This option will restore the original factory system defaults.



---

**NOTE:** Not all settings shown in the following sections are available for all models

---



**CAUTION:** Do NOT turn the computer power OFF while the BIOS is saving the Computer Setup (F10) changes because the CMOS could become corrupted. It is safe to turn off the computer only after exiting the F10 Setup screen.

---

## Computer Setup—Main



**NOTE:** Support for specific Computer Setup options may vary depending on the hardware configuration.

**Table 6-1 Computer Setup—Main**

Option	Description
<b>System Information</b>	<p>Lists all information in following list if <b>Advanced System Information</b> is selected. Lists smaller subset if <b>Basic System Information</b> is selected.</p> <ul style="list-style-type: none"><li>• Product Name</li><li>• Memory Size</li><li>• Processor Type</li><li>• Processor Cache Size</li><li>• Processor Speed</li><li>• MicroCode Revision</li><li>• Processor Stepping</li><li>• Memory Speed</li><li>• DIMM 1 Size</li><li>• DIMM 2 Size</li><li>• System BIOS version</li><li>• ME Firmware Version</li><li>• Integrated Video BIOS Revision</li><li>• Super I/O Firmware Version</li><li>• Born On Date</li><li>• Serial Number</li><li>• SKU number</li><li>• UUID (Universally Unique Identifier)</li><li>• Asset Tracking Number</li><li>• Feature Byte</li><li>• Build ID</li><li>• Product Family</li><li>• System Board ID</li><li>• System Board CT</li><li>• Integrated MAC Address</li></ul>
<b>System Diagnostics</b>	<p>Starts HP PC Hardware Diagnostics UEFI.</p> <p>Lets you perform the following functions:</p> <ul style="list-style-type: none"><li>• Memory Test</li><li>• Hard Drive Check</li><li>• Language</li></ul>
<b>Update System BIOS</b>	<p>Displays current BIOS information.</p> <p><b>Lock BIOS Version</b></p>

**Table 6-1 Computer Setup—Main (continued)**

Option	Description
	Clear to allow BIOS updates. Select to block BIOS updates.
	<b>Allow BIOS Updates Using a Network</b>
	Select to enable scheduled automatic BIOS updates through the network.
	<b>BIOS Update Preferences</b>
	Lets you configure BIOS updates through the network.
	<ul style="list-style-type: none"> <li>• Check for Update on Next Reboot</li> <li>• BIOS Source – select the source of the BIOS update from either HP.com or a custom URL.</li> <li>• Automatic BIOS Update Setting – select how BIOS is updated.</li> </ul>
	<b>NOTE:</b> BitLocker Drive Encryption (BDE) must be temporarily suspended to be able to flash the BIOS.
	<ul style="list-style-type: none"> <li>• BIOS Update Frequency – select how often the BIOS is updated. This setting is not active if <b>Automatic BIOS Update Setting</b> is set to 'Do no update'.</li> </ul>
	<b>Network Configuration Settings</b>
	Lets you configure upload and download settings.
	<ul style="list-style-type: none"> <li>• Proxy Server – select to enable use of a proxy server.</li> <li>• Edit Proxy Server – If Proxy Server is enabled, lets you specify the server address in &lt;server&gt;:&lt;port&gt; format.</li> <li>• Test Network Connection – select to check the network connection based on the selection in <b>Automatic BIOS Update Setting</b>.</li> <li>• IPv4 Configuration – select 'Automatic' or 'Manual'. If 'Manual' is selected, you can configure the address, subnet mask, and gateway.</li> <li>• DNS Configuration – select 'Automatic' or 'Manual'. If 'Manual' is selected, you can entered a list of DNS addresses.</li> <li>• Data transfer timeout – lets you configure the timeout setting. Select <b>Force HTTP no-cache</b> to disable HTTP caching.</li> </ul>
	<b>Update BIOS Using Local Media</b>
	Lets you update the system BIOS. BIOS update binary (BIN) files must be located on the system hard drive or on a removable USB drive under the "Hewlett-Packard\BIOS\New" folder or under the "EFI\HP\BIOS\New" folder. The files can also be placed in the "Hewlett-Packard\BIOS\Previous" folder or under the "EFI\HP\BIOS\Previous" folder.
<b>System IDs</b>	<p>Lets you clear the following values:</p> <ul style="list-style-type: none"> <li>• Asset Tracking Number</li> <li>• Ownership Tag</li> </ul>
<b>Replicated Setup</b>	<p><b>Backup current settings to USB device</b></p> <p>Saves system configuration to a formatted USB flash media device.</p> <p><b>Restore current settings from USB device</b></p> <p>Restores system configuration from a USB flash media device.</p>
<b>Save Custom Defaults</b>	Saves the current system configuration settings as the default.
<b>Apply Custom Defaults and Exit</b>	Applies the currently selected default settings and clears any established passwords.

**Table 6-1 Computer Setup—Main (continued)**

Option	Description
<b>Apply Factory Defaults and Exit</b>	Restores the factory system configuration settings as the default.
<b>Ignore Changes and Exit</b>	Exits Computer Setup without applying or saving any changes.
<b>Save Changes and Exit</b>	Saves changes to system configuration or default settings and exits Computer Setup.
<b>Suppress POST Errors</b>	<p>Suppresses most system messages during POST (Power On Self Test).</p> <p>POST error messages are displayed on the display during the Power On Self Test if the BIOS encounters a problem while starting the computer. A POST error message will only display on screen if the computer is capable of booting this far. If the POST detects an error before this point, a beep code is generated instead.</p>

## Computer Setup—Security



**NOTE:** Support for specific Computer Setup options may vary depending on the hardware configuration.

**Table 6-2 Computer Setup—Security**

Option	Description
<b>Create BIOS Administrator Password</b>	<p>Lets you set and enable a BIOS administrator password, which includes the following privileges:</p> <ul style="list-style-type: none"> <li>• Manage other BIOS users</li> <li>• Full access to BIOS policy and settings</li> <li>• Control BIOS access of other users by setting security level</li> <li>• Unlock the computer when other BIOS users fail the preboot authentication.</li> </ul> <p><b>NOTE:</b> Creating a BIOS user disables the Fast Boot option.</p> <p><b>NOTE:</b> If the password is set, it is required to change Computer Setup options, flash the ROM, and make changes to certain plug and play settings under Windows.</p>
<b>Change BIOS Administrator Password</b>  (This selection is active only if a BIOS administrator password is set.)	<p>Lets you change the BIOS administrator password.</p> <p>You must know the current password to be able to change it.</p>
<b>Password Policies</b>	<p>Let you set the guidelines for a valid password. Options include:</p> <ul style="list-style-type: none"> <li>• Password minimum length</li> <li>• Requires at least one symbol</li> <li>• Requires at least one number</li> <li>• Requires at least one upper case character</li> <li>• Requires at least one lower case character</li> <li>• Allow spaces</li> </ul> <p><b>Clear Password Jumper</b></p> <p>Select 'Honor' to engage or 'Ignore' to disengage the password jumper. Default is 'Honor'.</p>
<b>TPM Embedded Security</b>	Displays the TPM specification version.

**Table 6-2 Computer Setup—Security (continued)**

Option	Description
	<p>Lets you configure the following TPM settings:</p> <p><b>TPM Device</b></p> <p>Lets you set the Trusted Platform Module as available or hidden.</p> <p><b>TPM State</b></p> <p>Select to enable the TPM.</p> <p><b>Clear TPM</b></p> <p>Select to reset the TPM to an unowned state. After the TPM is cleared, it is also turned off. To temporarily suspend TPM operations, turn the TPM off instead of clearing it.</p> <p><b>CAUTION:</b> Clearing the TPM resets it to factory defaults and turns it off. You will lose all created keys and data protected by those keys.</p>
<b>BIOS SureStart</b>	<p>HP Sure Start verifies the integrity of HP BIOS code and critical, non-executable platform data residing in the main flash and provides self-healing mechanisms to restore any code or critical platform data that has been lost or is corrupted within the flash.</p> <p><b>Verify Boot Block on every boot</b></p> <p>Disabled (Default): When set to the default, HP Sure Start will verify the integrity of the BIOS in System Flash each time the system is in a Sleep, Hibernate, or Off state such that assurance is provided that it has not been tampered with before the host CPU executes that code as part of the process of resuming from the low power state.</p> <p>Enabled: When this box is checked, the HP Sure Start will continue to verify the integrity of the BIOS in System Flash each time the system is in a Sleep, Hibernate, or Off state. Additionally, the HP Sure Start will verify the integrity of the BIOS in System Flash on each Warm Boot (Windows Restart).</p> <p><b>BIOS Data Recovery Policy</b></p> <p>Automatic (Default): Any problems that are found by HP Sure Start will be automatically repaired not requiring any special actions by the local user.</p> <p>Manual (For Advanced Users only): Any problems found by HP Sure Start will not be repaired automatically and will require a special key sequence input by the local user to proceed with the repair. This mode is only intended for scenarios where the machine owner would prefer to perform forensics on the system flash contents before it is repaired and is not recommended for the typical user. In the case of HP Sure Start finding an issue with the initial BIOS code, the system will refuse to boot and flash a special LED sequence until the special key sequence is pressed on the internal keyboard.</p> <p>Network Controller Configuration Restore – This manual control will restore the network parameters (used by the Intel integrated network controller) stored in System Flash to their factory defaults.</p> <p><b>Dynamic Runtime Scanning of Boot Block</b></p> <p>Select to enable.</p>
<b>Smart Cover</b>	<p><b>Cover Lock</b> (Lock/Unlock)</p> <p>Default is 'Unlock'.</p> <p><b>Cover Removal Sensor</b> (Disabled/Notify user/Administrator password)</p> <p>Lets you disable the cover sensor or configure what action is taken if the computer cover was removed. Default is 'Disabled'.</p> <p><b>NOTE:</b> <b>Notify user</b> alerts the user that the sensor has detected that the cover has been removed. <b>Administrator Password</b> requires that the password be entered to boot the computer if the sensor detects that the cover has been removed.</p>
<b>Hard Drive Utilities</b>	<b>Save/Restore MBR of System Hard Drive</b>

**Table 6-2 Computer Setup—Security (continued)**

Option	Description
	<p>Enable to save the Master Boot Record (MBR) of the hard drive. If the MBR gets changed, the user is prompted to authorize restoring the MBR.</p> <p><b>DriveLock</b></p> <p>Allows you to assign or modify a master or user password for hard drives. When this feature is enabled, the user is prompted to provide one of the DriveLock passwords during POST. If neither is successfully entered, the hard drive will remain inaccessible until one of the passwords is successfully provided during a subsequent cold-boot sequence.</p> <p><b>NOTE:</b> This selection will only appear when at least one drive that supports the DriveLock feature is attached to the system.</p> <p><b>CAUTION:</b> Be aware that these settings take place immediately. A save is not necessary.</p> <p><b>CAUTION:</b> Be sure to document the DriveLock password. Losing a DriveLock password will render a drive permanently locked.</p> <p>After you select a drive, the following options are available:</p> <ul style="list-style-type: none"> <li>• <b>Set DriveLock Master Password.</b> Sets the drive's master password but does not enable DriveLock.</li> <li>• <b>Enable DriveLock.</b> Sets the drive's user password and enables DriveLock.</li> </ul> <p><b>Secure Erase</b></p> <p>Lets you select a hard drive to completely erase. Once a hard drive has been erased with a program that utilizes Secure Erase firmware commands, no file recovery program, partition recovery program, or other data recovery method will be able to extract data from the drive.</p>
<b>System Management Command</b>	Allows authorized personnel to reset security settings during a service event. Default is enabled.
<b>Restore Security Settings to Default</b>	Restoring settings to default requires the BIOS Administrator password.

## Computer Setup—Advanced



**NOTE:** Support for specific Computer Setup options may vary depending on the hardware configuration.

**Table 6-3 Computer Setup—Advanced (for advanced users)**

Option	Description
<b>Display Language</b>	Lets you select the language of the menus in F10 Setup and the keyboard.
<b>Scheduled Power-On</b>	This feature wakes the system up from a powered off state at a specified date and time.
<b>Boot Options</b>	<p><b>Startup Menu Delay(sec)</b></p> <p>Enabling this feature will add a user-specified delay to the POST process. This delay is sometimes needed for hard disks on some PCI cards that spin up very slowly, so slowly that they are not ready to boot by the time POST is finished. The POST delay also gives you more time to select <b>F10</b> to enter Computer (F10) Setup. Default is '0'.</p> <p>Select the devices that the computer can boot from, as well as other options, including:</p> <ul style="list-style-type: none"> <li>• Fast Boot. Default is disabled.</li> <li>• CD-ROM Boot. Default is enabled.</li> <li>• CD-ROM Boot. Default is enabled.</li> <li>• Network (PXE) Boot. Default is enabled.</li> </ul>

**Table 6-3 Computer Setup—Advanced (for advanced users) (continued)**

Option	Description
	<ul style="list-style-type: none"><li>• After Power Loss (off/on/previous state). Default is Power off. Setting this option to:<ul style="list-style-type: none"><li>◦ Power off—causes the computer to remain powered off when power is restored.</li><li>◦ Power on—causes the computer to power on automatically as soon as power is restored.</li><li>◦ Previous state—causes the computer to power on automatically as soon as power is restored, if it was on when power was lost.</li></ul></li><li>• Prompt on Memory Size Change. Default is enabled.</li><li>• Prompt on Fixed Storage Change. Default is disabled.</li><li>• Audio Alerts During Boot. Default is enabled.</li><li>• UEFI Boot Order. Default is enabled.</li><li>• Specify the order in which UEFI boot sources (such as a internal hard drive, USB hard drive, USB optical drive, or internal optical drive) are checked for a bootable operating system image. Each device on the list may be individually excluded from or included for consideration as a bootable operating system source.<p>UEFI boot sources always have precedence over legacy boot sources.</p></li><li>• <b>Legacy Boot Order</b><p>Specify the order in which legacy boot sources (such as a network interface card, internal hard drive, USB optical drive, or internal optical drive) are checked for a bootable operating system image. Each device on the list may be individually excluded from or included for consideration as a bootable operating system source.</p><p>Specify the order of attached hard drives. The first hard drive in the order will have priority in the boot sequence and will be recognized as drive C (if any devices are attached).</p></li></ul> <p><b>NOTE:</b> To drag a device to a preferred place, press <b>Enter</b>. To remove the device from consideration as a bootable device, press <b>F5</b>.</p> <p>You can use <b>F5</b> to disable individual boot items, as well as disable UEFI boot and/or legacy boot.</p> <p><b>NOTE:</b> MS-DOS drive lettering assignments may not apply after a non-MS-DOS operating system has started.</p>
	<p><b>Shortcut to Temporarily Override Boot Order</b></p> <p>To boot <b>one time</b> from a device other than the default device specified in Boot Order, restart the computer and press <b>Esc</b> (to access the boot menu) and then <b>F9</b> (Boot Order), or only <b>F9</b> (skipping the boot menu) when the monitor light turns green. After POST is completed, a list of bootable devices is displayed. Use the arrow keys to select the preferred bootable device and press <b>Enter</b>. The computer then boots from the selected non-default device for this one time.</p>
<b>Secure Boot Configuration</b>	<p><b>Configure Legacy Support and Secure Boot</b></p> <p>Legacy Support – Lets you turn off all legacy support on the computer, including booting to DOS, running legacy graphics cards, booting to legacy devices, and so on.</p> <p>Secure Boot – Lets you make sure an operating system is legitimate before booting to it, making Windows resistant to malicious modification from preboot to full OS booting, preventing firmware attacks. UEFI and Windows Secure Boot only allow code signed by pre-approved digital certificates to run during the firmware and OS boot process.</p> <p>Default is 'Legacy Support Enable and Secure Boot Disable'.</p> <p><b>Secure Boot Key Management</b></p> <p>Lets you manage the custom key settings.</p> <p><b>Clear Secure Boot Keys</b></p>

**Table 6-3 Computer Setup—Advanced (for advanced users) (continued)**

Option	Description
	Lets you delete any previously loaded custom boot keys. Clearing keys will disable secure boot. Default is disabled.
	<b>Reset Security Boot keys to factory defaults</b>
	Default is disabled.
	<b>Enable MS UEFI CA key</b>
	Lets you enabled the Certification Authority key. Default is enabled.
<b>System Options</b>	<b>Configure Storage Controller for RAID</b>
	Default is disabled. If enabled, <b>POST Prompt for RAID Configuration</b> becomes active. Selecting this option causes the RAID configuration to display during power-on self test (POST).
	<b>Turbo-boost</b>
	Enables processor feature that optimizes core frequencies can be optimized for performance based on the load on each core. Default is enabled.
	<b>Hyperthreading</b>
	Lets you control processor capability.
	<b>Virtualization Technology (VTx)</b>
	Enables the virtualization features of the processor. Changing this setting requires turning the computer off and then back on. Default is disabled.
	<b>Virtualization Technology for Directed IO (VTd)</b>
	Grants virtual machines direct access to peripheral devices on select Intel-based systems. Default is disabled.
	<b>M.2 WLAN/BT</b>
	Select to show the devices in the operating system. Default is enabled.
	<b>PCI Express x4 Slot 1</b>
	Select to show the devices in the operating system. Default is enabled.
	<b>PCI Express x4 Slot 2</b>
	Select to show the devices in the operating system. Default is enabled.
	<b>Allow PCIe/PCI SERR# Interrupt</b>
	Allows PCI devices to report PCI/PCIe System Error signals, such as address parity errors, data parity errors, and critical errors other than parity. Default is enabled.
	<b>Power Button Override (disable/4 sec/15 sec)</b>
	Lets you disable or enable and select the number of seconds you have to hold down the power button for it to override the system. Default is '4 sec'.
<b>Built-In Device Options</b>	<b>Embedded LAN Controller</b>
	Select to show the device in the operating system. Default is enabled.
	<b>Wake On LAN</b>
	Lets you either disable the Wake On LAN feature, or configure where the computer boots, including the network or hard drive. Default is Boot to Network.
	<b>Dust Filter</b>
	Select to enable.



**Table 6-3 Computer Setup—Advanced (for advanced users) (continued)**

Option	Description
	<p><b>Dust Filter Reminder</b> – If <b>Dust Filter</b> is enabled, you can set the number of days between reminder messages.</p>
	<p><b>M.2 USB/Bluetooth</b> Select to show the devices in the operating system. Default is disabled.</p>
	<p><b>Touch Device</b> Select to show the device in the operating system. Default is enabled.</p>
	<p><b>Audio Device</b> Select to show the device in the operating system. Default is enabled.</p>
	<p><b>Internal Speakers</b> (does not affect external speakers) Select to show the device in the operating system. Default is enabled.</p>
	<p><b>Increase Idle Fan Speed(%)</b> Sets idle fan speed percentage. This setting only changes the minimum fan speed. The fan is still automatically controlled.</p>
<b>Port Options</b>	<p>Allows you to configure specific ports and show or hide ports from the operating system. Clear the box to hide a device.</p> <ul style="list-style-type: none"> <li>• Serial port A</li> <li>• Serial port B</li> <li>• I/O Address A – Lets you manually set the I/O address. Available addresses are 3F8, 2F8, 3E8, 2E8.</li> <li>• I/O Address B – Lets you manually set the I/O address. Available addresses are 3F8, 2F8, 3E8, 2E8.</li> <li>• Interrupt A – Lets you manually set the interrupt signal. Available signals are IRQ 3, IRQ 4, IRQ 5, IRQ 10.</li> <li>• Interrupt B – Lets you manually set the interrupt signal. Available signals are IRQ 3, IRQ 4, IRQ 5, IRQ 10.</li> <li>• Serial Port Voltage A – Lets you change voltage settings for powered serial ports. Available voltage settings are 0v, 5V, 12V.</li> <li>• Serial Port Voltage B – Lets you change voltage settings for powered serial ports. Available voltage settings are 0v, 5V, 12V.</li> <li>• SATA0</li> <li>• SATA1</li> <li>• SATA4</li> <li>• Front USB ports</li> <li>• Rear USB ports</li> <li>• Cash Drawer Port</li> </ul> <p><b>Restrict USB Devices</b> Specify the following categories of USB devices to enable:</p> <ul style="list-style-type: none"> <li>• Allow all USB devices</li> <li>• Allow only keyboard and mouse</li> <li>• Allow all but storage devices and hubs.</li> </ul>

**Table 6-3 Computer Setup—Advanced (for advanced users) (continued)**

Option	Description
<b>Option ROM Launch Policy</b>	<p>These policies control whether the Legacy Option ROM or the UEFI driver is loaded. Default is 'All UEFI'.</p> <p><b>Configure Option ROM Launch Policy</b></p> <ul style="list-style-type: none"> <li>• All legacy</li> <li>• All UEFI</li> <li>• All UEFI except video</li> </ul>
<b>Power Management Options</b>	<p><b>Runtime Power Management</b> (enable/disable)</p> <p>Allows certain operating systems to reduce processor voltage and frequency when the current software load does not require the full capabilities of the processor. Default is enabled.</p> <p><b>Extended Idle Power States</b> (enable/disable)</p> <p>Allows certain operating systems to decrease the processors power consumption when the processor is idle. Default is enabled.</p> <p><b>S5 Maximum Power Savings</b> (enable/disable)</p> <p>Enabling this feature reduces the power of the system as much as possible in the S5 state. Power is removed from the wake up circuitry, the expansion slots, and any management features while in S5. Default is disabled.</p> <p><b>SATA Power Management</b> (enable/disable)</p> <p>Enables or disables SATA bus and/or device power management. Default is enabled.</p> <p><b>PCI Express Power Management</b> (enable/disable)</p> <p>Enabling this option permits the PCI Express links to use Active Power State Management (ASPM) to enter lower power states while not in use. Default is enabled.</p> <p><b>Unique Sleep State Blink Rates</b> (enable/disable)</p> <p>This feature is designed to provide a visual indication of what sleep state the system is in. Each sleep state has a unique blink pattern. Default is disabled.</p> <p><b>NOTE:</b> A normal shutdown goes to the S4 state.</p> <p>S0 (On) = Solid white LED.</p> <p>S3 (Stand By)= 3 blinks at 1Hz (50% duty cycle) followed by a pause of 2 seconds (white LED) — repeated cycles of 3 blinks and a pause.</p> <p>S4 (Hibernation)= 4 blinks at 1Hz (50% duty cycle) followed by a pause of 2 seconds (white LED) — repeated cycles of 4 blinks and a pause.</p> <p>S5 (Soft Off) = LED is off.</p>
<b>Remote Management Options</b>	<p>Allows you to set:</p> <p><b>Active Management (AMT)</b></p> <p>Lets you enable or disable functions of the embedded Management Engine (ME) such as Active Management Technology (AMT). If set to disable, the Management Engine is set to a temporarily disabled state and will not provide functions beyond necessary system configuration. Default is enabled.</p> <p><b>Unconfigure AMT on next boot</b></p> <p>Lets you unconfigure any provisioned management settings for AMT. The AMT settings are restored to factory defaults. This feature should be used with caution as AMT will not be able to provide any set AMT management functions once unconfigured. Default is disabled.</p> <p><b>SOL Terminal Emulation Mode</b></p> <p>Lets you specify terminal emulation mode. Options are 'ANSI' and 'VT100'.</p>

**Table 6-3 Computer Setup—Advanced (for advanced users) (continued)**

Option	Description
	<b>Verbose Boot Messages</b> Select to enable verbose boot messages. These messages indicate the processes or steps that the Windows operating system is taking in the background during startup, shutdown, logon, and logoff operations.
	<b>Watchdog Timer</b> Lets you set amount of time for a operating system and BIOS watchdog alert to be sent if the timers are not deactivated. BIOS watchdog is deactivated by BIOS and would indicate that a halt occurred during execution if the alert is sent to the management console. An operating system alert is deactivated by the operating system image and would indicate that a hang occurred during its initialization. Default is enabled.
	<b>CIRA Timeout (min.)</b> Client Initiated Remote Access (CIRA) enables out-of-band management systems, such as Intel AMT. It is intended to enable centralized corporate management and administration of notebook computers that are not attached to the corporate LAN, but rather are located off-site. Because off-site systems are typically behind a firewall, there is no way for the corporate administrator to directly find the computer. The system will initiate a connection to the corporate administration server, and the server can use this connection to administrator the computer.  Lets you set the CIRA timeout. Options are 'Never', '1 min', '2 mins', '3 mins', '4 mins'.

## Recovering the Configuration Settings

This method of recovery requires that you first perform the **Save to Removable Media** command with the Computer Setup (F10) Utility before **Restore** is needed. (See [Computer Setup—Main on page 64](#) in the Computer Setup—File table.)

 **NOTE:** It is recommended that you save any modified computer configuration settings to a USB flash media device and save the device for possible future use.

To restore the configuration, insert the USB flash media device with the saved configuration and perform the **Restore from Removable Media** command with the Computer Setup (F10) Utility. (See [Computer Setup—Main on page 64](#) in the Computer Setup—File table.)

# 7 POST error messages and diagnostic front panel LEDs and audible codes

This appendix lists the error codes, error messages, and the various indicator light and audible sequences that you may encounter during Power-On Self-Test (POST) or computer restart, the probable source of the problem, and steps you can take to resolve the error condition.

POST Message Disabled suppresses most system messages during POST, such as memory count and non-error text messages. If a POST error occurs, the screen will display the error message. To manually switch to the POST Messages Enabled mode during POST, press any key (except **F10**, **F11**, or **F12**). The default mode is POST Message Disabled.

The speed at which the computer loads the operating system and the extent to which it is tested are determined by the POST mode selection.

Quick Boot is a fast startup process that does not run all of the system level tests, such as the memory test. Full Boot runs all of the ROM-based system tests and takes longer to complete.

Full Boot may also be enabled to run every 1 to 30 days on a regularly scheduled basis. To establish the schedule, reconfigure the computer to the Full Boot Every x Days mode, using Computer Setup.

 **NOTE:** For more information on Computer Setup, see [Computer Setup \(F10\) Utility on page 62](#).

## POST numeric codes and text messages

This section covers those POST errors that have numeric codes associated with them. The section also includes some text messages that may be encountered during POST.

 **NOTE:** The computer will beep once after a POST text message is displayed on the screen.

Control panel message	Description	Recommended action
002-Option ROM Checksum Error	System ROM or expansion board option ROM checksum.	<ol style="list-style-type: none"><li>1. Verify the correct ROM.</li><li>2. Flash the ROM if needed.</li><li>3. If an expansion board was recently added, remove it to see if the problem remains.</li><li>4. Clear CMOS. (See <a href="#">Password security and resetting CMOS on page 81</a>.)</li><li>5. If the message disappears, there may be a problem with the expansion card.</li><li>6. Replace the system board.</li></ol>
003-System Board Failure	DMA or timers.	<ol style="list-style-type: none"><li>1. Clear CMOS. (See <a href="#">Password security and resetting CMOS on page 81</a>.)</li><li>2. Remove expansion boards.</li><li>3. Replace the system board.</li></ol>
005-Real-Time Clock Power Loss	Invalid time or date in configuration memory.	Reset the date and time under <b>Control Panel</b> (Computer Setup can also be used). If the

Control panel message	Description	Recommended action
	RTC (real-time clock) battery may need to be replaced.	problem persists, replace the RTC battery. See the Removal and Replacement section for instructions on installing a new battery.
008–Microcode Patch Error	Processor is not supported by the BIOS.	<ol style="list-style-type: none"> <li>1. Upgrade BIOS to proper version.</li> <li>2. Change the processor.</li> </ol>
009–PMM Allocation Error during MEBx Download	Memory error during POST execution of the Management Engine (ME) BIOS Extensions option ROM.	<ol style="list-style-type: none"> <li>1. Reboot the computer.</li> <li>2. Unplug the power cord, re-seat the memory modules, and reboot the computer.</li> <li>3. If the memory configuration was recently changed, unplug the computer, restore the original memory configuration, and reboot the computer.</li> <li>4. If the error persists, replace the system board.</li> </ol>
100-Front Audio Not Connected	Front audio cable has been detached or unseated from system board.	Reconnect or replace front audio cable.
00A-Product Information Not Valid	The product information programmed into the system board is missing or invalid.	Use Computer Setup to update this information.
00B-MEBx Module did not checksum correctly	Memory error during POST execution of the Management Engine (ME) BIOS Extensions option ROM.	<ol style="list-style-type: none"> <li>1. Reboot the computer.</li> <li>2. Unplug the power cord, re-seat the memory modules, and reboot the computer.</li> <li>3. If the memory configuration was recently changed, unplug the power cord, restore the original memory configuration, and reboot the computer.</li> <li>4. If the error persists, replace the system board.</li> </ol>
00C-PMM Deallocation Error during MEBx Cleanup	Memory error during POST execution of the Management Engine (ME) BIOS Extensions option ROM.	<ol style="list-style-type: none"> <li>1. Reboot the computer.</li> <li>2. Unplug the power cord, re-seat the memory modules, and reboot the computer.</li> <li>3. If the memory configuration was recently changed, unplug the power cord, restore the original memory configuration, and reboot the computer.</li> <li>4. If the error persists, replace the system board.</li> </ol>
00D-Setup Error during MEBx Execution	MEBx selection or exit resulted in a setup failure.	<ol style="list-style-type: none"> <li>1. Reboot the computer.</li> <li>2. Unplug the power cord, re-seat the memory modules, and reboot the computer.</li> <li>3. If the memory configuration was recently changed, unplug the power cord, restore the original memory configuration, and reboot the computer.</li> </ol>

Control panel message	Description	Recommended action
		<ol style="list-style-type: none"> <li>4. If the error persists, replace the system board.</li> </ol>
00E-Inventory Error during MEBx Execution	BIOS information passed to the MEBx resulted in a failure.	<ol style="list-style-type: none"> <li>1. Reboot the computer.</li> <li>2. If the error persists, update to the latest BIOS version.</li> <li>3. If the error still persists, replace the system board.</li> </ol>
00F-Interface Error during MEBx Execution	MEBx operation experienced a hardware error during communication with the ME.	<ol style="list-style-type: none"> <li>1. Reboot the computer.</li> <li>2. If the error persists, update to the latest BIOS version.</li> <li>3. If the error still persists, replace the system board.</li> </ol>
2E1-MemorySize Error	Memory amount has changed since the last boot (memory added or removed).	The system memory size is different from the last startup. The most common reason is the removal of memory from the system board. Press the <b>F1</b> key to save the memory changes. If this message persists, verify that the memory modules are installed correctly.
2E2-Memory Error	Memory module configuration failed during boot up.	<ol style="list-style-type: none"> <li>1. Ensure memory modules are correctly installed.</li> <li>2. Verify proper memory module type.</li> <li>3. Remove and replace the identified faulty memory module(s).</li> <li>4. If the error persists after replacing memory modules, replace the system board.</li> </ol>
2E3-Incompatible Memory Module in Memory Socket(s) X, X, ...	A memory module in memory socket identified in the error message is missing critical SPD information, or is incompatible with the chipset.	<ol style="list-style-type: none"> <li>1. Verify proper memory module type.</li> <li>2. Try another memory socket.</li> <li>3. Replace with a supported module.</li> </ol>
2E4-DIMM Configuration Warning	The current memory configuration is not optimized.	Rearrange the DIMMs so that each channel has the same amount of memory.
2E5-ECC Memory Module Detected on Unsupported Platform	Recently added memory module(s) support ECC memory error correction.	<ol style="list-style-type: none"> <li>1. If additional memory was recently added, remove it to see if the problem remains.</li> <li>2. Check product documentation for memory support information.</li> </ol>
2E6-Memory Not Configured Correctly for Proper MEBx Execution	DIMM1 is not installed.	Make sure there is a memory module in the DIMM1 socket and that it is properly seated.
300-Configuration Change Warning	The storage device configuration will be updated as shown.	Not applicable
301-Hard Disk 1: SMART Hard Drive Detects Imminent Failure	Hard drive is about to fail. (Some hard drives have a hard drive firmware patch that will fix an erroneous error message.)	<ol style="list-style-type: none"> <li>1. Determine if hard drive is giving correct error message. Run the Drive Protection System test under using F2 Diagnostics when booting the computer.</li> <li>2. Apply hard drive firmware patch if applicable. (Available at <a href="http://www.hp.com/support">http://www.hp.com/support</a>.)</li> </ol>

Control panel message	Description	Recommended action
302-Hard Disk 2: SMART Hard Drive Detects Imminent Failure	Hard drive is about to fail. (Some hard drives have a hard drive firmware patch that will fix an erroneous error message.)	<ol style="list-style-type: none"> <li>3. Back up contents and replace hard drive.</li> <li>1. Determine if hard drive is giving correct error message. Run the Drive Protection System test under using F2 Diagnostics when booting the computer.</li> <li>2. Apply hard drive firmware patch if applicable. (Available at <a href="http://www.hp.com/support">http://www.hp.com/support</a>.)</li> <li>3. Back up contents and replace hard drive.</li> </ol>
309 – 30C: Hard Disk 3–6: SMART Hard Drive Detects Imminent Failure	Hard drive is about to fail. (Some hard drives have a hard drive firmware patch that will fix an erroneous error message.)	<ol style="list-style-type: none"> <li>1. Determine if hard drive is giving correct error message. Run the Drive Protection System test under using F2 Diagnostics when booting the computer.</li> <li>2. Apply hard drive firmware patch if applicable. (Available at <a href="http://www.hp.com/support">http://www.hp.com/support</a>.)</li> <li>3. Back up contents and replace hard drive.</li> </ol>
3F0–Boot Device Not Found	Boot device not found.	Insert boot device or load operating system.
3F1–Hard Disk 1 Error	Hard disk 1 error.	<ol style="list-style-type: none"> <li>1. Check and/or replace cables.</li> <li>2. Clear CMOS. (See <a href="#">Password security and resetting CMOS on page 81</a>.)</li> <li>3. Replace the hard disk drive.</li> </ol>
3F2–Hard Disk 2 Error	Hard disk 2 error.	<ol style="list-style-type: none"> <li>1. Check and/or replace cables.</li> <li>2. Clear CMOS. (See <a href="#">Password security and resetting CMOS on page 81</a>.)</li> <li>3. Replace the hard disk drive.</li> </ol>
400–Serial Port A Address Conflict Detected	Both external and internal serial ports are assigned to the same resources.	<ol style="list-style-type: none"> <li>1. Remove any serial port expansion cards.</li> <li>2. Clear CMOS. (See <a href="#">Password security and resetting CMOS on page 81</a>.)</li> <li>3. Reconfigure card resources and/or run Computer Setup or Windows utilities.</li> </ol>
401–Serial Port B Address Conflict Detected	Both external and internal serial ports are assigned to the same resources.	<ol style="list-style-type: none"> <li>1. Remove any serial port expansion cards.</li> <li>2. Clear CMOS. (See <a href="#">Password security and resetting CMOS on page 81</a>.)</li> <li>3. Reconfigure card resources and/or run Computer Setup or Windows utilities.</li> </ol>
402–Serial Port C Address Conflict Detected	Both external and internal serial ports are assigned to the same resources.	<ol style="list-style-type: none"> <li>1. Remove any serial port expansion cards.</li> <li>2. Clear CMOS. (See <a href="#">Password security and resetting CMOS on page 81</a>.)</li> <li>3. Reconfigure card resources and/or run Computer Setup or Windows utilities.</li> </ol>
403–Serial Port D Address Conflict Detected	Both external and internal serial ports are assigned to the same resources.	<ol style="list-style-type: none"> <li>1. Remove any serial port expansion cards.</li> <li>2. Clear CMOS. (See <a href="#">Password security and resetting CMOS on page 81</a>.)</li> </ol>

Control panel message	Description	Recommended action
		<ol style="list-style-type: none"> <li>3. Reconfigure card resources and/or run Computer Setup or Windows utilities.</li> </ol>
419-Out of Memory Space for Option ROMs	Recently added PCI expansion card contains an option ROM too large to download during POST.	<p>▲ If a PCI expansion card was recently added, remove it to see if the problem remains.</p>
41A-Front USB1/USB2 Not Connected	Front USB cable has been detached or unseated from system board.	Reconnect or replace front USB cable.
41B-Device in PCI Express Slot Failed To Initialize	There is an incompatibility or problem with a PCIe device and the system or PCIe link could not be configured to a valid bus width or speed.	Try rebooting the system. If the error reoccurs, the device may not work with this system
43A-USB Type-C I2C Not Connected	Cable is required between I2C on card and USB-C on the system board.	Install cable between I2C on card and USB-C on the system board.
43B-More Than One USB type-C Cards Are Installed	More than one USB type-C card is installed.	Remove USB type-C card so only one is installed.
500-BIOS Recovery	A system BIOS recovery has occurred.	Not applicable.
60x-HP Battery Alert	The system has detected the storage capacity of the battery stated below to be very low.	For optimal performance, replace the battery.
70x-Wireless Mode Not Supported	The system has detected a wireless module installed in the system that is not supported and has been disabled.	Replace with a supported module.
800-Keyboard Error	Keyboard failure.	<ol style="list-style-type: none"> <li>1. Reconnect keyboard with computer turned off.</li> <li>2. Check connector for bent or missing pins.</li> <li>3. Ensure that none of the keys are depressed.</li> <li>4. Replace keyboard.</li> </ol>
801-Keyboard or System Unit Error	Keyboard failure.	<ol style="list-style-type: none"> <li>1. Reconnect the keyboard with computer turned off.</li> <li>2. Ensure that none of the keys are depressed.</li> <li>3. Replace the keyboard.</li> <li>4. Replace the system board.</li> </ol>
900-CPU Fan Not Detected	CPU fan is not connected or may have malfunctioned.	<ol style="list-style-type: none"> <li>1. Reseat CPU fan.</li> <li>2. Reseat fan cable.</li> <li>3. Replace CPU fan.</li> </ol>
901-Chassis, Rear Chassis, or Front Chassis Fan not Detected	Chassis, rear chassis, or front chassis fan is not connected or may have malfunctioned.	<ol style="list-style-type: none"> <li>1. Reseat chassis, rear chassis, or front chassis fan.</li> <li>2. Reseat fan cable.</li> <li>3. Replace chassis, rear chassis, or front chassis fan.</li> </ol>
904-SATA Cabling Error	One or more SATA devices are improperly attached. For optimal performance, the SATA 0 and SATA 1 ports should be used for hard drives before other ports.	Ensure SATA connectors are used in ascending order. For one device, use SATA 0. For two devices, use SATA 0 and SATA 1. For three devices, use SATA 0, SATA 1, and SATA 2.



Control panel message	Description	Recommended action
910-Filter Warning	Airflow filter is dirty.	Replace the airflow filter.
90B-Fan Failure	The system has detected that a cooling fan is not operating correctly.	<ol style="list-style-type: none"> <li>1. Reseat fan.</li> <li>2. Reseat fan cable.</li> <li>3. Replace fan.</li> </ol>
90D-System Temperature	Thermal shutdown occurred. The system BIOS has detected your machine was previously shut down to avoid overheating. Overheating may occur if the cooling vents are blocked or the operating temperature exceeds the system specifications. The machine should return to normal operation once the situation is resolved.	Make sure system has proper airflow.
90E-Power Supply Fan Not detected	Power supply fan is not connected or may have malfunctioned.	<ol style="list-style-type: none"> <li>1. Reseat power supply fan.</li> <li>2. Reseat fan cable.</li> <li>3. Replace power supply fan.</li> </ol>

## Interpreting system validation diagnostic front panel LEDs and audible codes

During the system validation phase that occurs at system startup, the BIOS validates the functionality of the following subsystems and conditions:

- AC adapter
- System board power
- Processor failure
- BIOS corruption
- Memory failure
- Graphics failure
- System board failure
- BIOS authentication failure

If an error is detected, specific patterns of long and short blinks, accompanied by long and short beeps (where applicable) are used to identify the error. These patterns will make up a two part code:

- Major – the category of the error
- Minor – the specific error within the category



**NOTE:** Single beep/blink codes are not used.

Number of long beeps/blinks	Error category
1	Not used
2	BIOS
3	Hardware

Number of long beeps/blinks	Error category
4	Thermal
5	System board

Patterns of blink/beep codes are determined by using the following parameters:

- 1 second pause occurs after the last major blink.
- 2 second pause occurs after the last minor blink.
- Beep error code sequences occur for the first 5 iterations of the pattern and then stop.
- Blink error code sequences continue until the computer is unplugged or the power button is pressed.



**NOTE:** Not all diagnostic lights and audible codes are available on all models.

The red LED blinks to represent the major error category (long blinks). The white LED blinks to represent the minor error category (short blinks). For example, '3.5' indicates 3 long red blinks and 5 short white blinks to communicate the processor is not detected.

Category	Major/minor code	Description
BIOS	2.2	The main area (DXE) of BIOS has become corrupted and there is no recovery binary image available.
	2.3	The embedded controller policy requires the user to enter a key sequence.
	2.4	The embedded controller is checking or recovering the boot block.
Hardware	3.2	The embedded controller has timed out waiting for BIOS to return from memory initialization.
	3.3	The embedded controller has timed out waiting for BIOS to return from graphics initialization.
	3.4	The system board displays a power failure (crowbar).*
	3.5	The processor is not detected.*
	3.6	The processor does not support an enabled feature.
Thermal	4.2	A processor over temperature condition has been detected.*
	4.3	An ambient temperature over temperature condition has been detected.
	4.4	An MXM over temperature condition has been detected.
System board	5.2	The embedded controller cannot find valid firmware.
	5.3	The embedded controller has timed out waiting for the BIOS.
	5.4	The embedded controller has timed out waiting for BIOS to return from system board initialization.
	5.5	The embedded controller rebooted the system after a possible lockup condition had been detected through the use of a System Health Timer, Automated System Recovery Timer, or other mechanism.

\* Indicates hardware triggered event; all other events are controlled by the BIOS.

---

## 8 Password security and resetting CMOS

This computer supports security password features, which can be established through the Computer Setup Utilities menu.

This computer supports two security password features that are established through the Computer Setup Utilities menu: setup password and power-on password. When you establish only a setup password, any user can access all the information on the computer except Computer Setup. When you establish only a power-on password, the power-on password is required to access Computer Setup and any other information on the computer. When you establish both passwords, only the setup password will give you access to Computer Setup.

When both passwords are set, the setup password can also be used in place of the power-on password as an override to log in to the computer. This is a useful feature for a network administrator.

If you forget the password for the computer, you can clear that password so you can gain access to the information on the computer by resetting the password jumper.

---

 **CAUTION:** Pushing the CMOS button will reset CMOS values to factory defaults. It is important to back up the computer CMOS settings before resetting them in case they are needed later. Back up is easily done through Computer Setup. See [Computer Setup \(F10\) Utility on page 62](#) for information on backing up the CMOS settings.

---

### Resetting the password jumper

---

 **CAUTION:** If you enable the stringent security feature in Computer Setup and you forget the setup password or the power-on password, the computer is inaccessible and can no longer be used.

Enabling the stringent password disables the ability to reset the password by moving the jumper on the system board.

If you lose or forget the password, the system board must be replaced. This scenario is not covered under warranty.

To prevent the computer from becoming permanently unusable, record your configured setup password or power-on password in a safe place away from your computer. Without these passwords, the computer cannot be unlocked.

---

To disable the power-on or setup password features, or to clear the power-on or setup passwords, complete the following steps:

1. Shut down the operating system properly, then turn off the computer and any external devices, and disconnect the power cord from the power outlet.
2. With the power cord disconnected, press the power button again to drain the system of any residual power.

---

 **WARNING!** To reduce the risk of personal injury from electrical shock and/or hot surfaces, be sure to disconnect the power cord from the wall outlet, and allow the internal system components to cool before touching.

 **CAUTION:** When the computer is plugged in, the power supply always has voltage applied to the system board even when the unit is turned off. Failure to disconnect the power cord can result in damage to the system.

Static electricity can damage the electronic components of the computer or optional equipment. Before beginning these procedures, ensure that you are discharged of static electricity by briefly touching a grounded metal object. See the *Safety & Regulatory Information* guide for more information.

---

3. Remove the access panel.
4. Locate the header and jumper.

---

 **NOTE:** The password jumper is blue so that it can be easily identified. For assistance locating the password jumper and other system board components, see the system board components image at [System board on page 53](#).

---

5. Remove the jumper from pins 1 and 2.
6. Place the jumper on either pin 1 or 2, but not both, so that it does not get lost.
7. Replace the access panel and reconnect the external equipment.
8. Plug in the computer and turn on power. Allow the operating system to start. This clears the current passwords and disables the password features.
9. Shut down the computer, unplug the power, and disconnect the external equipment.
10. Remove the access panel.
11. Place the jumper on pins 1 and 2.
12. Replace the access panel.
13. Reconnect the external equipment and plug in the computer.

## Changing a Setup or Power-On password

To change the power-on or setup password, complete the following steps:

1. Turn on or restart the computer.
  - To change the Setup password, go to step 2.
  - To change the Power-on password, go to step 3.
2. To change the Setup password, as soon as the computer turns on:
  - Press the Esc key while “Press the ESC key for Startup Menu” message is displayed.
  - Press the F10 key to enter Computer Setup.

3. When the key icon appears, type your current password, a slash (/) or alternate delimiter character, your new password, another slash (/) or alternate delimiter character, and your new password again as shown:

*current password/new password/new password*



---

**NOTE:** Type the new password carefully since the characters do not appear on the screen.

---

4. Press [Enter](#).

The new password will take effect the next time the computer is restarted.

## Deleting a Setup or Power-On password

To delete the power-on or setup password, complete the following steps:

1. Turn on or restart the computer.  
To delete the Setup password, go to step 2.  
To delete the Power-on password, go to step 3.
2. To delete the Setup password, as soon as the computer turns on:
  - Press the Esc key while “Press the ESC key for Startup Menu” message is displayed.
  - Press the F10 key to enter Computer Setup.
3. When the key icon appears, type your current password, a slash (/) or alternate delimiter character, your new password, another slash (/) or alternate delimiter character, and your new password again as shown:  
*current password/*
4. Press [Enter](#).

## Clearing and resetting the CMOS

The computer’s configuration memory (CMOS) stores information about the computer’s configuration.

The CMOS button resets CMOS but does not clear the power-on and setup passwords.

1. Turn off the computer and any external devices, and disconnect the power cord from the power outlet.
2. Disconnect external equipment connected to the computer.



---

**WARNING!** To reduce the risk of personal injury from electrical shock and/or hot surfaces, be sure to disconnect the power cord from the wall outlet, and allow the internal system components to cool before touching.



**CAUTION:** When the computer is plugged in, the power supply always has voltage applied to the system board even when the unit is turned off. Failure to disconnect the power cord can result in damage to the system.

Static electricity can damage the electronic components of the computer or optional equipment. Before beginning these procedures, ensure that you are discharged of static electricity by briefly touching a grounded metal object. See the *Safety & Regulatory Information* guide for more information.

---

3. Remove the access panel.

---

**CAUTION:** Pushing the CMOS button will reset CMOS values to factory defaults. It is important to back up the computer CMOS settings before resetting them in case they are needed later. Back up is easily done through Computer Setup. See [Computer Setup \(F10\) Utility on page 62](#) for information on backing up the CMOS settings.

---

4. Locate, press, and hold the CMOS button in for five seconds.

**NOTE:** Make sure you have disconnected the AC power cord from the wall outlet. The CMOS button will not clear CMOS if the power cord is connected.

---



**NOTE:** For assistance locating the CMOS button and other system board components, see the system board components image at [System board on page 53](#).

---

5. Replace the access panel.
6. Reconnect the external devices.
7. Plug in the computer and turn on power.

**NOTE:** You will receive POST error messages after clearing CMOS and rebooting advising you that configuration changes have occurred. Use Computer Setup to reset any special system setups along with the date and time.

---

For instructions on Computer Setup, see [Computer Setup \(F10\) Utility on page 62](#).

## 9 Using HP PC Hardware Diagnostics (UEFI)

HP PC Hardware Diagnostics is a Unified Extensible Firmware Interface (UEFI) that allows you to run diagnostic tests to determine whether the computer hardware is functioning properly. The tool runs outside the operating system so that it can isolate hardware failures from issues that are caused by the operating system or other software components.

When HP PC Hardware Diagnostics (UEFI) detects a failure that requires hardware replacement, a 24-digit Failure ID code is generated. This ID code can then be provided to support to help determine how to correct the problem.

---

 **NOTE:** To start diagnostics on a convertible computer, your computer must be in notebook mode and you must use the keyboard attached.

---

To start HP PC Hardware Diagnostics (UEFI), follow these steps:

1. Turn on or restart the computer, and quickly press [esc](#).
2. Press [f2](#).

The BIOS searches three places for the diagnostic tools, in the following order:

- a. Connected USB drive

---

 **NOTE:** To download the HP PC Hardware Diagnostics (UEFI) tool to a USB drive, see [Downloading HP PC Hardware Diagnostics \(UEFI\) to a USB device on page 85](#).

---

- b. Hard drive

- c. BIOS

3. When the diagnostic tool opens, select the type of diagnostic test you want to run, and then follow the on-screen instructions.

---

 **NOTE:** If you need to stop a diagnostic test, press [esc](#).

---

## Downloading HP PC Hardware Diagnostics (UEFI) to a USB device

---

 **NOTE:** The HP PC Hardware Diagnostics (UEFI) download instructions are provided in English only, and you must use a Windows computer to download and create the HP UEFI support environment because only .exe files are offered.

---

There are two options to download HP PC Hardware Diagnostics to a USB device.

### Download the latest UEFI version

1. Go to <http://www.hp.com/go/techcenter/pcdiags>. The HP PC Diagnostics home page is displayed.
2. In the HP PC Hardware Diagnostics section, click the **Download** link, and then select **Run**.

### Download any version of UEFI for a specific product

1. Go to <http://www.hp.com/support>, and then select your country. The HP Support page is displayed.
2. Click **Drivers & Downloads**.

3. Use the categories listed to find your product.

– or –

Click **Find Now** to let HP automatically detect your product.

4. Select your computer, and then select your operating system.
5. In the **Diagnostic** section, follow the on-screen instructions to select and download the UEFI version you want.



---

# 10 Troubleshooting without diagnostics

This chapter provides information on how to identify and correct minor problems, such as USB devices, hard drive, optical drive, graphics, audio, memory, and software problems. If you encounter problems with the computer, refer to the tables in this chapter for probable causes and recommended solutions.

 **NOTE:** For information on specific error messages that may appear on the screen during Power-On Self-Test (POST) at startup, refer to [POST error messages and diagnostic front panel LEDs and audible codes on page 74](#).

---

## Safety and comfort

 **WARNING!** Misuse of the computer or failure to establish a safe and comfortable work environment may result in discomfort or serious injury. Refer to the *Safety & Comfort Guide* at <http://www.hp.com/ergo> for more information on choosing a workspace and creating a safe and comfortable work environment. For more information, refer to the *Safety & Regulatory Information* guide.

---

## Before you call for technical support

 **IMPORTANT:** Always be sure to load the latest BIOS and drivers, available from <http://support.hp.com/>.

---

If you are having problems with the computer, try the appropriate solutions below to try to isolate the exact problem before calling for technical support.

- Run the HP diagnostic tool.
- Run the hard drive self-test in Computer Setup. Refer to [Computer Setup \(F10\) Utility on page 62](#) for more information.
- Check the Power LED on the front of the computer to see if it is flashing red. The flashing lights are error codes that will help you diagnose the problem. Refer to [POST error messages and diagnostic front panel LEDs and audible codes on page 74](#) for more information.
- If the screen is blank, plug the monitor into a different video port on the computer if one is available. Or, replace the monitor with a monitor that you know is functioning properly.
- If you are working on a network, plug another computer with a different cable into the network connection. There may be a problem with the network plug or cable.
- If you recently added new hardware, remove the hardware and see if the computer functions properly.
- If you recently installed new software, uninstall the software and see if the computer functions properly.
- Boot the computer to the Safe Mode to see if it will boot without all of the drivers loaded. When booting the operating system, use “Last Known Configuration.”
- Refer to the comprehensive online technical support at <http://www.hp.com/support>.
- Refer to [Helpful hints on page 88](#) in this guide.

To assist you in resolving problems online, HP Instant Support Professional Edition provides you with self-solve diagnostics. If you need to contact HP support, use HP Instant Support Professional Edition's online chat feature. Access HP Instant Support Professional Edition at: <http://www.hp.com/go/ispe>.

Access the Business Support Center (BSC) at <http://www.hp.com/go/bizsupport> for the latest online support information, software and drivers, proactive notification, and worldwide community of peers and HP experts.

If it becomes necessary to call for technical assistance, be prepared to do the following to ensure that your service call is handled properly:

- Be in front of your computer when you call.
- Write down the computer serial number, product ID number, and monitor serial number before calling.
- Spend time troubleshooting the problem with the service technician.
- Remove any hardware that was recently added to your system.
- Remove any software that was recently installed.
- Restore the system from the Recovery Disc Set that you created or restore the system to its original factory condition in System Software Requirement Disks (SSRD).

---

 **CAUTION:** Restoring the system will erase all data on the hard drive. Be sure to back up all data files before running the restore process.

 **NOTE:** For sales information and warranty upgrades (Care Packs), call your local authorized service provider or dealer.

---

## Helpful hints

---

 **IMPORTANT:** Always be sure to load the latest BIOS and drivers, available from <http://support.hp.com/>.

---

If you encounter problems with the computer, monitor, or software, see the following list of general suggestions before taking further action:

- Check that the computer and monitor are plugged into a working electrical outlet.
- Check that the voltage select switch (some models) is set to the appropriate voltage for your region (115V or 230V).
- Check that the computer is turned on and the white power light is on.
- Check that the monitor is turned on and the green monitor light is on.
- Check the Power LED on the front of the computer to see if it is flashing red. The flashing lights are error codes that will help you diagnose the problem. Refer to [POST error messages and diagnostic front panel LEDs and audible codes on page 74](#) for more information.
- Turn up the brightness and contrast controls of the monitor if the monitor is dim.
- Press and hold any key. If the system beeps, then the keyboard should be operating correctly.
- Check all cable connections for loose connections or incorrect connections.
- Wake the computer by pressing any key on the keyboard or pressing the power button. If the system remains in suspend mode, shut down the computer by pressing and holding the power button for at least four seconds then press the power button again to restart the computer. If the system will not shut down, unplug the power cord, wait a few seconds, then plug it in again. The computer will restart if it is set to power on automatically as soon as power is restored in Computer Setup. If it does not restart, press the power button to start the computer.
- Reconfigure the computer after installing a non-plug and play expansion board or other option. See [Solving hardware installation problems on page 100](#) for instructions.

- Be sure that all the needed device drivers have been installed. For example, if you are using a printer, you need a driver for that model printer.
- Remove all bootable media (CD/DVD or USB device) from the system before turning it on.
- If you have installed an operating system other than the factory-installed operating system, check to be sure that it is supported on the system.
- If the system has multiple video sources (embedded, PCI, or PCI-Express adapters) installed (embedded video on some models only) and a single monitor, the monitor must be plugged into the monitor connector on the source selected as the primary VGA adapter. During boot, the other monitor connectors are disabled and if the monitor is connected into these ports, the monitor will not function. You can select which source will be the default VGA source in Computer Setup.

 **CAUTION:** When the computer is plugged into an AC power source, there is always voltage applied to the system board. You must disconnect the power cord from the power source before opening the computer to prevent system board or component damage.

## Solving retail system-specific problems

The issues listed in this section are specific to features available in this retail system.

 **IMPORTANT:** Always be sure to load the latest BIOS and drivers, available from <http://support.hp.com/>.

### Powered serial ports do not have power.

Cause	Solution
Ports are not correctly configured in Computer Setup.	<ol style="list-style-type: none"> <li>1. Run the Computer Setup utility.</li> <li>2. Under <b>Advanced &gt; Port Options</b>, make sure the correct setting is selected for each individual serial port (A, B).  Available settings are: <ul style="list-style-type: none"> <li>• 0v</li> <li>• 5v</li> <li>• 12v</li> </ul> </li> </ol>
A powered serial device was connected while system power	<p>The computer must be powered off when you plug in powered serial devices.</p> <p>Disconnect the device, power off the system, plug in the device, and power on the system.</p>

### Fingerprint reader does not work.

Cause	Solution
The fingerprint reader only works when installed in the orientation it was registered in.	If the position of the fingerprint reader has been changed, you must re-register the fingerprint reader.

**Serial Port Devices do not function after hot swapping. Hot swapping is when connecting or disconnecting a serial device while the system is powered on.**

Cause	Solution
RPOS platform serial ports do not support hot swapping.	To ensure that serial device drivers load and to avoid hardware damage, power the system off before connecting or disconnecting serial devices. Hot plugging serial devices is not supported and doing so can cause permanent hardware damage and void warranty.

**The magnetic strip reader (MSR) beeps or blinks in an unusual way or card data is incomplete or garbled.**

Cause	Solution
The MSR may be improperly configured or has become defective.	Try cleaning the MSR. Swipe a standard cleaning card through the MSR a couple of times to clean the MSR. You can order a standard cleaning card online. Alternately, you can create a cleaning card by putting a thin, oil free cloth around a credit card.

**A new MSR does not work.**

Cause	Solution
The new MSR needs to be configured with the system settings using HP USB Mini Magnetic Stripe Reader (MSR) Configuration Software.	<ol style="list-style-type: none"><li>1. Connect the old MSR (the one being replaced).</li><li>2. Start HP magnetic stripe reader configuration utility (<a href="http://h20564.www2.hp.com/hpsc/swd/public/detail?swItemId=ir_125989_1&amp;swEnvOid=4047">http://h20564.www2.hp.com/hpsc/swd/public/detail?swItemId=ir_125989_1&amp;swEnvOid=4047</a>).</li><li>3. Retrieve the configuration details from the old MSR and save.</li><li>4. Connect the new MSR (the replacement).</li><li>5. Write the saved configuration to the new MSR.</li></ol>

## Solving general problems

You may be able to easily resolve the general problems described in this section. If a problem persists and you are unable to resolve it yourself or if you feel uncomfortable about performing the operation, contact an authorized dealer or reseller.

**⚠ WARNING!** When the computer is plugged into an AC power source, voltage is always applied to the system board. To reduce the risk of personal injury from electrical shock and/or hot surfaces, be sure to disconnect the power cord from the wall outlet and allow the internal system components to cool before touching.

**Cannot access the Computer Setup (F10) Utility when booting the computer.**

Cause	Solution
The Computer Setup (F10) Utility is set to “fast boot” causing the F10 access screen to display too briefly when booting the computer.	Before turning on the computer, press and hold <b>F10</b> . Turn on the computer and continue to hold <b>F10</b> until the Computer Setup (F10) Utility is displayed.
	- or -

---

**Cannot access the Computer Setup (F10) Utility when booting the computer.**

---

Cause	Solution
	Follow the Windows instructions for rebooting the computer into the Computer Setup (F10) Utility.

---

---

**Computer appears locked up and will not turn off when the power button is pressed.**

---

Cause	Solution
Software control of the power switch is not functional.	<ol style="list-style-type: none"><li>1. Press and hold the power button for at least four seconds until the computer turns off.</li><li>2. Disconnect the power cord from the electrical outlet.</li></ol>

---

---

**Computer will not respond to keyboard or mouse.**

---

Cause	Solution
Computer is in Sleep state.	To resume from Sleep state, press the power button. <b>CAUTION:</b> When attempting to resume from Sleep state, do not hold down the power button for more than four seconds. Otherwise, the computer will shut down and you will lose any unsaved data.
System has locked up.	Restart computer.

---

---

**Computer date and time display is incorrect.**

---

Cause	Solution
RTC (real-time clock) battery may need to be replaced. <b>NOTE:</b> Connecting the computer to a live AC outlet prolongs the life of the RTC battery.	Reset the date and time under <b>Control Panel</b> (Computer Setup can also be used to update the RTC date and time). If the problem persists, replace the RTC battery. See the Removal and Replacement section for instructions on installing a new battery, or contact an authorized dealer or reseller for RTC battery replacement.  To access Control Panel in Windows 7, select <b>Start</b> , and then select <b>Control Panel</b> .  To access Control Panel in Windows 8.1, from the Start screen, type <code>c</code> , and then select <b>Control Panel</b> from the list of applications.  To access Control Panel in Windows 10, type <code>control panel</code> in the taskbar search box, and then select Control Panel.

---

---

**There is no sound or sound volume is too low.**

---

Cause	Solution
System volume may be set low or muted.	<ol style="list-style-type: none"><li>1. Check the Computer Setup settings to make sure the internal system speaker is not muted (this setting does not affect the external speakers).</li></ol>

---

**There is no sound or sound volume is too low.**

<b>Cause</b>	<b>Solution</b>
	<ol style="list-style-type: none"><li>2. Make sure the external speakers are properly connected and powered on and that the speakers' volume control is set correctly.</li><li>3. Use the system volume control available in the operating system to make sure the speakers are not muted or to increase the volume.</li></ol>

**Cannot remove computer cover or access panel.**

<b>Cause</b>	<b>Solution</b>
Smart Cover Lock, featured on some computers, is locked.	Unlock the Smart Cover Lock using Computer Setup.  In case of forgotten password, power loss, or computer malfunction, you must manually disable the Smart Cover lock . A key to unlock the Smart Cover Lock is not available from HP. Keys are typically available from a hardware store.

**Poor performance.**

<b>Cause</b>	<b>Solution</b>
Processor is too hot.	<ol style="list-style-type: none"><li>1. Make sure airflow to the computer is not blocked. Leave a 10.2-cm (4-inch) clearance on all vented sides of the computer and above the monitor to permit the required airflow.</li><li>2. Make sure fans are connected and working properly (some fans only operate when needed).</li><li>3. Make sure the processor heat sink is installed properly.</li></ol>
Hard drive is full.	Transfer data from the hard drive to create more space on the hard drive.
Low on memory.	Add more memory.
Hard drive fragmented.	Defragment hard drive.
Program previously accessed did not release reserved memory back to the system.	Restart the computer.
Virus resident on the hard drive.	Run virus protection program.
Too many applications running.	<ol style="list-style-type: none"><li>1. Close unnecessary applications to free up memory.</li><li>2. Add more memory.</li><li>3. Some applications run in the background and can be closed by right-clicking on their corresponding icons in the task tray. To prevent these applications from launching at startup:  In Windows 7:<ol style="list-style-type: none"><li>a. Go to <b>Start &gt; All Programs &gt; Accessories &gt; Run</b></li><li>b. Type <code>msconfig</code>, and then press <a href="#">Enter</a>.</li></ol></li></ol>

### Poor performance.

Cause	Solution
	<ul style="list-style-type: none"><li>c. On the <b>Startup</b> tab of the System Configuration Utility, clear applications that you do not want to launch automatically, and the click <b>OK</b>.</li></ul> <p>In Windows 8.1:</p> <ul style="list-style-type: none"><li>a. On the Start screen, right-click, and then select the <b>All apps</b> icon.</li><li>b. Under <b>Windows System</b>, click <b>Run</b>.</li><li>c. Type <code>msconfig</code>, and then press <b>Enter</b>.</li><li>d. On the <b>Startup</b> tab of the System Configuration Utility, clear applications that you do not want to launch automatically, and the click <b>OK</b>.</li></ul> <p>In Windows 10:</p> <ul style="list-style-type: none"><li>a. Type <code>msconfig</code> in the taskbar search box, and then select <b>msconfig</b>.</li><li>b. On the <b>Startup</b> tab of the System Configuration Utility, click <b>Open Task Manager</b>.</li><li>c. Select applications that you do not want to launch automatically, and the click <b>Disable</b>.</li></ul>
Some software applications, especially games, are stressful on the graphics subsystem.	<ul style="list-style-type: none"><li>1. Lower the display resolution for the current application or consult the documentation that came with the application for suggestions on how to improve performance by adjusting parameters in the application.</li><li>2. Add more memory.</li><li>3. Upgrade the graphics solution.</li></ul>
Cause unknown.	Restart the computer.

### Computer powered off automatically and the Power LED flashes red four times and then white two times.

Cause	Solution
Processor thermal protection activated: A fan may be blocked or not turning. OR The heat sink is not properly attached to the processor.	<ul style="list-style-type: none"><li>1. Ensure that the computer air vents are not blocked and the processor cooling fan is running.</li><li>2. Open the access panel, press the power button, and see if the processor fan (or other system fan) spins. If the fan does not spin, make sure the fan cable is plugged onto the system board header.</li><li>3. If fan a plugged in and not spinning, replace it.</li></ul>

### System does not power on and the LEDs on the front of the computer are not flashing.

Cause	Solution
System unable to power on.	Press and hold the power button for less than 4 seconds. If the hard drive LED turns white, then:

**System does not power on and the LEDs on the front of the computer are not flashing.**

Cause	Solution
	<ol style="list-style-type: none"><li data-bbox="858 262 1436 367">1. If equipped with a voltage selector, check that the voltage selector (located on the rear of the power supply) is set to the appropriate voltage. Proper voltage setting depends on your region.</li><li data-bbox="858 388 1436 451">2. Remove the expansion cards one at a time until the 5V_aux light on the system board turns on.</li><li data-bbox="858 472 1436 493">3. Replace the system board.</li></ol> <p data-bbox="858 514 885 535">OR</p> <p data-bbox="858 556 1436 609">Press and hold the power button for less than 4 seconds. If the hard drive LED does not turn on white then:</p> <ol style="list-style-type: none"><li data-bbox="858 630 1436 651">1. Check that the unit is plugged into a working AC outlet.</li><li data-bbox="858 672 1436 724">2. Open the access panel and check that the power button cable is properly connected to the system board.</li><li data-bbox="858 745 1436 798">3. Check that the power supply cables are properly connected to the system board.</li><li data-bbox="858 819 1436 892">4. Check to see if the 5V_aux light on the system board is turned on. If it is turned on, then replace the power button assembly.</li><li data-bbox="858 913 1436 966">5. If the 5V_aux light on the system board is off, then replace the power supply.</li><li data-bbox="858 987 1436 1008">6. Replace the system board.</li></ol>

## Solving hard drive problems

**Hard drive error occurs.**

Cause	Solution
Hard disk has bad sectors or has failed.	<ol style="list-style-type: none"><li data-bbox="858 1270 1436 1732">1. In Windows 7, click <b>Start</b>, click <b>Computer</b>, and right-click on a drive. Select <b>Properties</b>, and then select the <b>Tools</b> tab. Under <b>Error-checking</b> click <b>Check Now</b>.  In Windows 8.1, on the Start screen type <b>e</b>, and then select <b>File Explorer</b> from the list of applications. In the left column, expand <b>Computer</b>, right-click on a drive, select <b>Properties</b>, and then select the <b>Tools</b> tab. Under <b>Error checking</b> click <b>Check</b>.  In Windows 10, type <b>file</b> in the taskbar search box, and then select <b>File Explorer</b> from the list of applications. In the left column, expand <b>This PC</b>, right-click on a drive, select <b>Properties</b>, and then select the <b>Tools</b> tab. Under <b>Error checking</b> click <b>Check</b>.</li><li data-bbox="858 1680 1436 1732">2. Use a utility to locate and block usage of bad sectors. If necessary, reformat the hard disk.</li></ol>



### Disk transaction problem.

Cause	Solution
Either the directory structure is bad or there is a problem with a file.	<p>In Windows 7, click <b>Start</b>, expand <b>Computer</b>, and right-click on a drive. Select <b>Properties</b>, and then select the <b>Tools</b> tab. Under <b>Error-checking</b> click <b>Check Now</b>.</p> <p>In Windows 8.1, on the Start screen type <code>e</code>, and then click <b>File Explorer</b> from the list of applications. In the left column, expand <b>Computer</b>, right-click on a drive, select <b>Properties</b>, and then select the <b>Tools</b> tab. Under <b>Error checking</b> click <b>Check</b>.</p> <p>In Windows 10, type <code>file</code> in the taskbar search box, and then select <b>File Explorer</b> from the list of applications. In the left column, expand <b>This PC</b>, right-click on a drive, select <b>Properties</b>, and then select the <b>Tools</b> tab. Under <b>Error checking</b> click <b>Check</b>.</p>

### Drive not found (identified).

Cause	Solution
Cable could be loose.	Check cable connections.
The system may not have automatically recognized a newly installed device.	<p>See reconfiguration directions in the <a href="#">Solving hardware installation problems on page 100</a> section. If the system still does not recognize the new device, check to see if the device is listed within Computer Setup. If it is listed, the probable cause is a driver problem. If it is not listed, the probable cause is a hardware problem.</p> <p>If this is a newly installed drive, run the Computer Setup utility and try adding a POST delay under <b>Advanced &gt; Boot Options</b>.</p>
The device is attached to a SATA port that has been hidden in Computer Setup.	Run the Computer Setup utility and ensure <b>Device Available</b> is selected for the device's SATA port in <b>Advanced &gt; Port Options</b> .
Drive responds slowly immediately after power-up.	Run Computer Setup and increase the POST Delay in <b>Advanced &gt; Boot Options</b> .

### Nonsystem disk/NTLDR missing message.

Cause	Solution
The system is trying to start from the hard drive but the hard drive may have been damaged.	▲ Perform Drive Protection System (DPS) testing in system ROM.
System files missing or not properly installed.	<ol style="list-style-type: none"><li>1. Insert bootable media and restart the computer.</li><li>2. Boot to the windows installation media and select the recovery option. If only a restore kit is available, then select the <b>File Backup Program</b> option, and then restore the system.</li><li>3. Install system files for the appropriate operating system.</li></ol>
Hard drive boot has been disabled in Computer Setup.	Run the Computer Setup utility and enable the hard drive entry in the <b>Advanced &gt; Boot Options</b> list.

### Nonsystem disk/NTLDR missing message.

Cause	Solution
Bootable hard drive is not attached as first in a multi-hard drive configuration.	If attempting to boot from a hard drive, ensure it is attached to the system board dark blue SATA connector.
Bootable hard drive is not listed first in the Boot Order.	Run the Computer Setup utility and select <b>Advanced &gt; Boot Options</b> and ensure the bootable hard drive is listed immediately under the <b>Hard Drive</b> entry.

### Computer will not boot from hard drive.

Cause	Solution
The device is attached to a SATA port that has been hidden in Computer Setup.	<ol style="list-style-type: none"><li>1. Check SATA cable connections.</li><li>2. Run the Computer Setup utility and ensure <b>Device Available</b> is selected for the device's SATA port in <b>Advanced &gt; Port Options</b>.</li></ol>
Boot order is not correct.	Run the Computer Setup utility and change boot sequence in <b>Advanced &gt; Boot Options</b> .
Hard drive is damaged.	Observe if the front panel Power LED is blinking RED and if any beeps are heard. See <a href="#">POST error messages and diagnostic front panel LEDs and audible codes on page 74</a> to determine possible causes for the blinking red and beep codes.  See the Worldwide Limited Warranty for terms and conditions.

### Computer seems to be locked up.

Cause	Solution
Program in use has stopped responding to commands.	<ol style="list-style-type: none"><li>1. Use the task manager to close programs that do not respond.</li><li>2. Attempt the normal Windows "Shut Down" procedure. If this fails, press the power button for four or more seconds to turn off the power. To restart the computer, press the power button again.</li></ol>

# Solving audio problems

If the computer has audio features and you encounter audio problems, see the common causes and solutions listed in the following table.

## Sound cuts in and out.

Cause	Solution
Processor resources are being used by other open applications.	Shut down all open processor-intensive applications.

## Sound does not come out of the speaker or headphones.

Cause	Solution
Software volume control is turned down or muted.	Double-click the <b>Speaker</b> icon on the taskbar, then make sure that <b>Mute</b> is not selected and use the volume slider to adjust the volume.  <b>NOTE:</b> In Windows 8.1, the taskbar is available at the bottom of the Desktop screen.
Audio is hidden in Computer Setup.	Enable the audio in Computer Setup: <b>Advanced &gt; Built-in Device Options</b> .
The external speakers are not turned on.	Turn on the external speakers.
The audio device may be connected to the wrong jack.	Ensure that the device is connected to the correct jack on the computer. The rear audio jack output is the green receptacle. The speakers should be plugged into the line-out jack and the headphones should be plugged into the headphone jack.
External speakers plugged into the wrong audio jack on a recently installed sound card.	See the sound card documentation for proper speaker connection. The rear audio jack output is the green receptacle.
Headphones or devices connected to the line-out connector mute the internal speaker.	Turn on and use headphones or external speakers, if connected, or disconnect headphones or external speakers.
Computer is in Sleep state.	Press the power button to resume from Sleep state.  <b>CAUTION:</b> When attempting to resume from Sleep state, do not hold down the power button for more than four seconds. Otherwise, the computer will shut down and you will lose any unsaved data.
Internal speaker is disabled in Computer Setup.	Enable the internal speaker in Computer Setup. Select <b>Advanced &gt; Built-in Device Options</b> .
The application is set to use a different audio device than speakers.	Some graphics cards support audio over the DisplayPort connection (if applicable), so multiple audio devices may be listed in Device Manager. Make sure the correct device is being used.  To access Device Manager in Windows 7, click <b>Start</b> , select <b>Control Panel</b> , and then select <b>Device Manager</b> .  To access Device Manager in Windows 8.1, from the Start screen, type <b>c</b> , select <b>Control Panel</b> from the list of applications, and then select <b>Device Manager</b> .  To access Device Manager in Windows 10, type <code>device manager</code> in the taskbar search box, and then select <b>Device Manager</b> from the list of applications.

---

**Sound does not come out of the speaker or headphones.**

---

**Cause****Solution**

Some applications can select which audio output device is used.

Make sure the application has selected the correct audio device.

The operating system controls may be set to use a different audio device as the default output device than what is expected.

Set the operating system to use the correct audio device.

---

---

**Sound from headphones is not clear or muffled.**

---

**Cause****Solution**

Headphones are plugged into the rear audio output connector. The rear audio output connector is for powered audio devices and is not designed for headphone use.

Plug the headphones into the headphone connector on the front of the computer.

---

---

**Computer appears to be locked up while recording audio.**

---

**Cause****Solution**

The hard disk may be full.

Before recording, make sure there is enough free space on the hard disk. You can also try recording the audio file in a compressed format.

---

---

**Line-in jack is not functioning properly.**

---

**Cause****Solution**

Jack has been reconfigured in the audio driver or application software.

In the audio driver or application software, reconfigure the jack or set the jack to its default value.

---

---

**There is no sound or sound volume is too low.**

---

**Cause****Solution**

The application is set to use a different audio device than speakers.

Some graphics cards support audio over the DisplayPort connection (if applicable), so multiple audio devices may be listed in Device Manager. Make sure the correct device is being used.

To access Device Manager in Windows 7, click **Start**, select **Control Panel**, and then select **Device Manager**.

To access Device Manager in Windows 8.1, from the Start screen, type **c**, select **Control Panel** from the list of applications, and then select **Device Manager**.

To access Device Manager in Windows 10, type `device manager` in the taskbar search box, and then select **Device Manager** from the list of applications.

Some applications can select which audio output device is used.

Make sure the application has selected the correct audio device.

The operating system controls may be set to use a different audio device as the default output device than what is expected.

Set the operating system to use the correct audio device.

---

# Solving printer problems

If you encounter printer problems, see the documentation that came with the printer and to the common causes and solutions listed in the following table.

## Printer will not print.

Cause	Solution
Printer is not turned on and online.	Turn the printer on and make sure it is online.
The correct printer drivers for the application are not installed.	<ol style="list-style-type: none"><li>1. Install the correct printer driver for the application.</li><li>2. Try printing using the MS-DOS command: <pre>DIR C:\ &gt; [printer port]</pre>where [printer port] is the address of the printer being used. If the printer works, reload the printer driver.  To run MS-DOS commands, press the Windows key + <b>r</b>, type <code>cmd</code> in the <b>Open</b> box, and then click <b>OK</b>.</li></ol>
If you are on a network, you may not have made the connection to the printer.	Make the proper network connections to the printer.
Printer may have failed.	Run printer self-test.

## Printer will not turn on.

Cause	Solution
The cables may not be connected properly.	Reconnect all cables and check the power cord and electrical outlet.

## Printer prints garbled information.

Cause	Solution
The correct printer driver for the application is not installed.	Install the correct printer driver for the application.
The cables may not be connected properly.	Reconnect all cables.
Printer memory may be overloaded.	Reset the printer by turning it off for one minute, then turn it back on.

## Printer will not print.

Cause	Solution
The printer may be out of paper.	Check the paper tray and refill it if it is empty.

## Solving hardware installation problems

You may need to reconfigure the computer when you add or remove hardware, such as an additional drive or expansion card. If you install a plug and play device, Windows automatically recognizes the device and configures the computer. If you install a non-plug and play device, you must reconfigure the computer after completing installation of the new hardware. In Windows, use the **Add Hardware Wizard** and follow the instructions that appear on the screen.

To open the Add Hardware Wizard, open a Command Prompt and open `hdwwiz.exe`.

**⚠ WARNING!** When the computer is plugged into an AC power source, voltage is always applied to the system board. To reduce the risk of personal injury from electrical shock and/or hot surfaces, be sure to disconnect the power cord from the wall outlet and allow the internal system components to cool before touching.

**Table 10-1 Solving Hardware Installation Problems**

**A new device is not recognized as part of the system.**

Cause	Solution
Device is not seated or connected properly.	Ensure that the device is properly and securely connected and that pins in the connector are not bent down.
Cable(s) of new external device are loose or power cables are unplugged.	Ensure that all cables are properly and securely connected and that pins in the cable or connector are not bent down.
Power switch of new external device is not turned on.	Turn off the computer, turn on the external device, then turn on the computer to integrate the device with the computer system.
When the system advised you of changes to the configuration, you did not accept them.	Reboot the computer and follow the instructions for accepting the changes.
A plug and play board may not automatically configure when added if the default configuration conflicts with other devices.	Use Windows Device Manager to deselect the automatic settings for the board and choose a basic configuration that does not cause a resource conflict. You can also use Computer Setup to reconfigure or disable devices to resolve the resource conflict.  To access Device Manager in Windows 7, click <b>Start</b> , select <b>Control Panel</b> , and then select <b>Device Manager</b> .  To access Device Manager in Windows 8.1, from the Start screen, type <b>c</b> , select <b>Control Panel</b> from the list of applications, and then select <b>Device Manager</b> .  To access Device Manager in Windows 10, type <code>device manager</code> in the taskbar search box, and then select <b>Device Manager</b> from the list of applications.
USB ports on the computer are disabled in Computer Setup.	Run the Computer Setup utility and ensure that <b>Device available</b> is selected for appropriate USB ports under <b>Advanced &gt; Port Options</b> .

**Computer will not start.**

Cause	Solution
Wrong memory modules were used in the upgrade or memory modules were installed in the wrong location.	<ol style="list-style-type: none"><li>1. Review the documentation that came with the system to determine if you are using the correct memory modules and to verify the proper installation.  <b>NOTE:</b> DIMM1 or XMM1 must always be installed. DIMM1 must be installed before DIMM3.</li></ol>

**Computer will not start.**

Cause	Solution
	<ol style="list-style-type: none"> <li>2. Observe the beeps and LED lights on the front of the computer. Beeps and flashing LEDs are codes for specific problems.</li> <li>3. If you still cannot resolve the issue, contact Customer Support.</li> </ol>

**Power LED flashes Red three times and then white two times.**

Cause	Solution
Memory is installed incorrectly or is bad.	<p><b>CAUTION:</b> To avoid damage to the DIMMs or the system board, you must unplug the computer power cord before attempting to reseat, install, or remove a DIMM module.</p> <ol style="list-style-type: none"> <li>1. Reseat DIMMs. Power on the system.</li> <li>2. Replace DIMMs one at a time to isolate the faulty module.</li> </ol> <p><b>NOTE:</b> DIMM1 or XMM1 must always be installed. DIMM1 must be installed before DIMM3.</p> <ol style="list-style-type: none"> <li>3. Replace third-party memory with HP memory.</li> <li>4. Replace the system board.</li> </ol>

## Solving Network Problems

Some common causes and solutions for network problems are listed in the following table. These guidelines do not discuss the process of debugging the network cabling.

**Table 10-2 Solving Network Problems**

**Network driver does not detect network controller.**

Cause	Solution
Network controller is disabled.	<ol style="list-style-type: none"> <li>1. Run Computer Setup and enable network controller.</li> <li>2. Enable the network controller in the operating system using Device Manager. <p>To access Device Manager in Windows 7, click <b>Start</b>, select <b>Control Panel</b>, and then select <b>Device Manager</b>.</p> <p>To access Device Manager in Windows 8.1, from the Start screen, type <b>c</b>, select <b>Control Panel</b> from the list of applications, and then select <b>Device Manager</b>.</p> <p>To access Device Manager in Windows 10, type <code>device manager</code> in the taskbar search box, and then select <b>Device Manager</b> from the list of applications.</p> </li> </ol>
Incorrect network driver.	Check the network controller documentation for the correct driver or obtain the latest driver from the manufacturer's Web site.

**Network status link light never flashes.**

**NOTE:** The network status light is supposed to flash when there is network activity.

Cause	Solution
No active network is detected.	Check cabling and network equipment for proper connection.
Network controller is not set up properly.	<p>Check for the device status within Windows, such as Device Manager for driver load and the Network Connections applet within Windows for link status.</p> <p>To access Device Manager in Windows 7, click <b>Start</b>, select <b>Control Panel</b>, and then select <b>Device Manager</b>.</p> <p>To access Device Manager in Windows 8.1, from the Start screen, type <b>c</b>, select <b>Control Panel</b> from the list of applications, and then select <b>Device Manager</b>.</p> <p>To access Device Manager in Windows 10, type <code>device manager</code> in the taskbar search box, and then select <b>Device Manager</b> from the list of applications.</p>
Network controller is disabled.	<ol style="list-style-type: none"><li>1. Run Computer Setup and enable network controller.</li><li>2. Enable the network controller in the operating system using Device Manager.</li></ol> <p>To access Device Manager in Windows 7, click <b>Start</b>, select <b>Control Panel</b>, and then select <b>Device Manager</b>.</p> <p>To access Device Manager in Windows 8.1, from the Start screen, type <b>c</b>, select <b>Control Panel</b> from the list of applications, and then select <b>Device Manager</b>.</p> <p>To access Device Manager in Windows 10, type <code>device manager</code> in the taskbar search box, and then select <b>Device Manager</b> from the list of applications.</p>
Network driver is not properly loaded.	Reinstall network drivers.
System cannot autosense the network.	Disable auto-sensing capabilities and force the system into the correct operating mode.

**Diagnostics reports a failure.**

Cause	Solution
The cable is not securely connected.	Ensure that the cable is securely attached to the network connector and that the other end of the cable is securely attached to the correct device.
The cable is attached to the incorrect connector.	Ensure that the cable is attached to the correct connector.
There is a problem with the cable or a device at the other end of the cable.	Ensure that the cable and device at the other end are operating correctly.
The network controller is defective.	Contact an authorized service provider.



---

**Diagnostics passes, but the computer does not communicate with the network.**

---

<b>Cause</b>	<b>Solution</b>
Network drivers are not loaded, or driver parameters do not match current configuration.	Make sure the network drivers are loaded and that the driver parameters match the configuration of the network controller.  Make sure the correct network client and protocol is installed.
The network controller is not configured for this computer.	Select the <b>Network and Sharing Center</b> icon in the <b>Control Panel</b> and configure the network controller.  To access Control Panel in Windows 7, click <b>Start</b> , and then select <b>Control Panel</b> .  To access Control Panel in Windows 8.1, from the Start screen, type <b>c</b> , and then select <b>Control Panel</b> .  To access Control Panel in Windows 10, type <code>control panel</code> in the taskbar search box, and then select <b>Control Panel</b> from the list of applications.

---

---

**Network controller stopped working when an expansion board was added to the computer.**

---

<b>Cause</b>	<b>Solution</b>
The network controller requires drivers.	Verify that the drivers were not accidentally deleted when the drivers for a new expansion board were installed.

---

---

**Network controller stops working without apparent cause.**

---

<b>Cause</b>	<b>Solution</b>
The files containing the network drivers are corrupted.	Reinstall the network drivers using the Recovery Disc Set in Windows 7 or Windows recovery tools in Windows 8.1.  If necessary, download the softpaq from the web (from a different computer).
The cable is not securely connected.	Ensure that the cable is securely attached to the network connector and that the other end of the cable is securely attached to the correct device.
The network controller is defective.	Contact an authorized service provider.

---

---

**New network card will not boot.**

---

<b>Cause</b>	<b>Solution</b>
New network card may be defective or may not meet industry-standard specifications.	Install a working, industry-standard NIC, or change the boot sequence to boot from another source.

---

**Cannot connect to network server when attempting Remote System Installation.**

Cause	Solution
The network controller is not configured properly.	Verify Network Connectivity, that a DHCP Server is present, and that the Remote System Installation Server contains the NIC drivers for your NIC.

**System setup utility reports unprogrammed EEPROM.**

Cause	Solution
Unprogrammed EEPROM.	Contact an authorized service provider.

## Solving memory problems

If you encounter memory problems, some common causes and solutions are listed in the following table.

 **CAUTION:** Power may still be supplied to the DIMMs when the computer is turned off (depending on the Management Engine (ME) settings). To avoid damage to the DIMMs or the system board, you must unplug the computer power cord before attempting to reseat, install, or remove a memory module.

For those systems that support ECC memory, HP does not support mixing ECC and non-ECC memory. Otherwise, the computer will not boot the operating system.

 **NOTE:** The memory count will be affected by configurations with the Management Engine (ME) enabled. The ME uses 8MB of system memory in single channel mode or 16MB of memory in dual-channel mode to download, decompress, and execute the ME firmware for Out-of-Band (OOB), third-party data storage, and other management functions.

**System will not boot or does not function properly after installing additional memory modules.**

Cause	Solution
A memory module is not installed in the DIMM1 or XMM1 socket.	Ensure that a memory module is installed in the DIMM1 or XMM1 socket on the system board. This socket must be populated with a memory module.
Memory module is not the correct type or speed grade for the system or the new memory module is not seated properly.	Replace module with the correct industry-standard device for the computer. On some models, ECC and non-ECC memory modules cannot be mixed.

**Out of memory error.**

Cause	Solution
You have run out of memory to run the application.	Check the application documentation to determine the memory requirements.

**Memory count during POST is wrong.**

Cause	Solution
The memory modules may not be installed correctly.	Check that the memory modules have been installed correctly and that proper modules are used.
Integrated graphics may use system memory.	No action required.

**Insufficient memory error during operation.**

Cause	Solution
Too many Terminate and Stay Resident programs (TSRs) are installed.	Delete any TSRs that you do not need.
You have run out of memory for the application.	Check the memory requirements for the application or add more memory to the computer.

**Power LED flashes Red five times, once every second, followed by a two second pause, and the computer beeps five times. (Beeps stop after fifth iteration but LEDs continue flashing.)**

Cause	Solution
Memory is installed incorrectly or is bad.	<ol style="list-style-type: none"><li>1. Reseat DIMMs. Power on the system.</li><li>2. Replace DIMMs one at a time to isolate the faulty module.</li><li>3. Replace third-party memory with HP memory.</li><li>4. Replace the system board.</li></ol>

## Solving USB flash drive problems

If you encounter USB flash drive problems, common causes and solutions are listed in the following table.

**USB flash drive is not seen as a drive letter in Windows.**

Cause	Solution
The drive letter after the last physical drive is not available.	Change the default drive letter for the flash drive in Windows.

**USB flash drive not found (identified).**

Cause	Solution
The device is attached to a USB port that has been hidden in Computer Setup.	Run the Computer Setup utility and enable USB ports in <b>Advanced &gt; Port Options</b> .
The device was not properly seated before power-up.	Ensure the device is fully inserted into the USB port before applying power to the system

### System will not boot from USB flash drive.

Cause	Solution
Boot order is not correct.	Run the Computer Setup utility and change boot sequence in <b>Advanced &gt; Boot Options</b> .
Removable Media Boot is disabled in the Computer Setup utility.	Run the Computer Setup utility and enable booting to removable media in <b>Advanced &gt; Boot Options</b> . Ensure USB is enabled in <b>Storage &gt; Boot Order</b> .

### The computer boots to DOS after making a bootable flash drive.

Cause	Solution
Flash drive is bootable.	Install the flash drive only after the operating system boots.
Flash drive is defective.	Try a different flash drive.

## Solving Internet access problems

If you encounter Internet access problems, consult your Internet Service Provider (ISP) or refer to the common causes and solutions listed in the following table.

### Unable to connect to the Internet.

Cause	Solution
Internet Service Provider (ISP) account is not set up properly.	Verify Internet settings or contact your ISP for assistance.
Web browser is not set up properly.	Verify that the Web browser is installed and set up to work with your ISP.
Cable/DSL modem is not plugged in.	Plug in cable/DSL modem. You should see a “power” LED light on the front of the cable/DSL modem.
Cable/DSL service is not available or has been interrupted due to bad weather.	Try connecting to the Internet at a later time or contact your ISP. (If the cable/DSL service is connected, the “cable” LED light on the front of the cable/DSL modem will be on.)
The CAT5 UTP cable is disconnected.	Connect the CAT5 UTP cable between the cable modem and the computer’s RJ-45 connector. (If the connection is good, the “PC” LED light on the front of the cable/DSL modem will be on.)
IP address is not configured properly.	Contact your ISP for the correct IP address.
Cookies are corrupted. (A “cookie” is a small piece of information that a Web server can store temporarily with the Web browser. This is useful for having the browser remember some specific information that the Web server can later retrieve.)	Windows 7: <ol style="list-style-type: none"><li>1. Select <b>Start &gt; Control Panel</b>.</li><li>2. Click <b>Internet Options</b>.</li><li>3. In the <b>Browsing history</b> section on the <b>General</b> tab, click the <b>Delete</b> button.</li><li>4. Select the <b>Cookies</b> check box and click the <b>Delete</b> button.</li></ol> Windows 8.1: <ol style="list-style-type: none"><li>1. From the Start screen, type <b>c</b>, and then select <b>Control Panel</b> from the list of applications.</li></ol>

### Unable to connect to the Internet.

Cause	Solution
	<ol style="list-style-type: none"><li>2. Click <b>Internet Options</b>.</li><li>3. In the <b>Browsing history</b> section on the <b>General</b> tab, click the <b>Delete</b> button.</li><li>4. Select the <b>Cookies</b> check box and click the <b>Delete</b> button.</li></ol> <p>Windows 10:</p> <ol style="list-style-type: none"><li>1. Type <code>control panel</code> in the taskbar search box, and then select <b>Control Panel</b> from the list of applications.</li><li>2. Click <b>Internet Options</b>.</li><li>3. In the <b>Browsing history</b> section, click the <b>Delete</b> button.</li><li>4. Select the <b>Cookies and website data</b> check box and click the <b>Delete</b> button.</li></ol>

### Cannot automatically launch Internet programs.

Cause	Solution
You must log on to your ISP before some programs will start.	Log on to your ISP and launch the desired program.

## Solving software problems

Most software problems occur as a result of the following:

- The application was not installed or configured correctly.
- There is insufficient memory available to run the application.
- There is a conflict between applications.
- Be sure that all the needed device drivers have been installed.
- If you have installed an operating system other than the factory-installed operating system, check to be sure it is supported on the system.

If you encounter software problems, see the applicable solutions listed in the following table.

### **Computer will not continue and the HP logo does not display.**

<b>Cause</b>	<b>Solution</b>
ROM issue - POST error has occurred.	Observe the beeps and LED lights on the front of the computer. See <a href="#">POST error messages and diagnostic front panel LEDs and audible codes on page 74</a> to determine possible causes.  See the Worldwide Limited Warranty for terms and conditions.

### **“Illegal Operation has Occurred” error message is displayed.**

<b>Cause</b>	<b>Solution</b>
Software being used is not Microsoft-certified for your version of Windows.	Verify that the software is certified by Microsoft for your version of Windows (see program packaging for this information).
Configuration files are corrupt.	If possible, save all data, close all programs, and restart the computer.

---

# 11 System backup and recovery

## Backing up, restoring, and recovering in Windows 10

This section provides information about the following processes. The information in the section is standard procedure for most products.

- Creating recovery media and backups
- Restoring and recovering your system

For additional information, refer to Help and Support.

- ▲ Type `help` in the taskbar search box, and then select **Help and Support**.

### Creating recovery media and backups

The following methods of creating recovery media and backups are available on select products only. Choose the available method according to your computer model.

- Use HP Recovery Manager to create HP Recovery media after you successfully set up the computer. This step creates a backup of the HP Recovery partition on the computer. The backup can be used to reinstall the original operating system in cases where the hard drive is corrupted or has been replaced. For information on creating recovery media, see [Creating HP Recovery media \(select products only\) on page 109](#). For information on the recovery options that are available using the recovery media, see [What you need to know before you get started on page 111](#).
- Use Windows tools to create system restore points and create backups of personal information.

For more information, see [Using Windows tools on page 111](#).



---

**NOTE:** If storage is 32 GB or less, Microsoft System Restore is disabled by default.

---

### Creating HP Recovery media (select products only)

If possible, check for the presence of the Recovery partition and the Windows partition. From the Start menu, select **File Explorer**.

- If your computer does not list the Windows partition and the Recovery partition, you can obtain recovery media for your system from support. See the *Worldwide Telephone Numbers* booklet included with the computer. You can also find contact information on the HP website. Go to <http://www.hp.com/support>, select your country or region, and follow the on-screen instructions.

You can use Windows tools to create system restore points and create backups of personal information, see [Using Windows tools on page 111](#).

- If your computer does list the Recovery partition and the Windows partition, you can use HP Recovery Manager to create recovery media after you successfully set up the computer. HP Recovery media can be used to perform system recovery if the hard drive becomes corrupted. System recovery reinstalls the original operating system and software programs that were installed at the factory and then configures the settings for the programs. HP Recovery media can also be used to customize the system or restore the factory image if you replace the hard drive.

- Only one set of recovery media can be created. Handle these recovery tools carefully, and keep them in a safe place.
- HP Recovery Manager examines the computer and determines the required storage capacity for the media that will be required.
- To create recovery discs, your computer must have an optical drive with DVD writer capability, and you must use only high-quality blank DVD-R, DVD+R, DVD-R DL, or DVD+R DL discs. Do not use rewritable discs such as CD±RW, DVD±RW, double-layer DVD±RW, or BD-RE (rewritable Blu-ray) discs; they are not compatible with HP Recovery Manager software. Or, instead, you can use a high-quality blank USB flash drive.
- If your computer does not include an integrated optical drive with DVD writer capability, but you would like to create DVD recovery media, you can use an external optical drive (purchased separately) to create recovery discs. If you use an external optical drive, it must be connected directly to a USB port on the computer; the drive cannot be connected to a USB port on an external device, such as a USB hub. If you cannot create DVD media yourself, you can obtain recovery discs for your computer from HP. See the *Worldwide Telephone Numbers* booklet included with the computer. You can also find contact information on the HP website. Go to <http://www.hp.com/support>, select your country or region, and follow the on-screen instructions.
- Be sure that the computer is connected to AC power before you begin creating the recovery media.
- The creation process can take an hour or more. Do not interrupt the creation process.
- If necessary, you can exit the program before you have finished creating all of the recovery DVDs. HP Recovery Manager will finish burning the current DVD. The next time you start HP Recovery Manager, you will be prompted to continue.

To create HP Recovery media:

1. Type `recovery` in the taskbar search box, and then select **HP Recovery Manager**.
2. Select **Create recovery media**, and then follow the on-screen instructions.

If you ever need to recover the system, see [Recovering using HP Recovery Manager on page 111](#).



## Using Windows tools

You can create recovery media, system restore points, and backups of personal information using Windows tools.

---

 **NOTE:** If storage is 32 GB or less, Microsoft System Restore is disabled by default.

---

For more information and steps, see Help and Support.

- ▲ Type `help` in the taskbar search box, and then select Help and Support.

## Restore and recovery

There are several options for recovering your system. Choose the method that best matches your situation and level of expertise:

---

 **IMPORTANT:** Not all methods are available on all products.

---

- Windows offers several options for restoring from backup, refreshing the computer, and resetting the computer to its original state. For more information see Help and Support.
  - ▲ Type `help` in the taskbar search box, and then select **Help and Support**.
- If you need to correct a problem with a preinstalled application or driver, use the Reinstall drivers and/or applications option (select products only) of HP Recovery Manager to reinstall the individual application or driver.
  - ▲ Type `recovery` in the taskbar search box, select **HP Recovery Manager**, select **Reinstall drivers and/or applications**, and then follow the on-screen instructions.
- If you want to recover the Windows partition to original factory content, you can choose the System Recovery option from the HP Recovery partition (select products only) or use the HP Recovery media. For more information, see [Recovering using HP Recovery Manager on page 111](#). If you have not already created recovery media, see [Creating HP Recovery media \(select products only\) on page 109](#).
- On select products, if you want to recover the computer's original factory partition and content, or if you have replaced the hard drive, you can use the Factory Reset option of HP Recovery media. For more information, see [Recovering using HP Recovery Manager on page 111](#).
- On select products, if you want to remove the recovery partition to reclaim hard drive space, HP Recovery Manager offers the Remove Recovery Partition option.

For more information, see [Removing the HP Recovery partition \(select products only\) on page 113](#).

## Recovering using HP Recovery Manager

HP Recovery Manager software allows you to recover the computer to its original factory state by using the HP Recovery media that you either created or that you obtained from HP, or by using the HP Recovery partition (select products only). If you have not already created recovery media, see [Creating HP Recovery media \(select products only\) on page 109](#).

### What you need to know before you get started

- HP Recovery Manager recovers only software that was installed at the factory. For software not provided with this computer, you must either download the software from the manufacturer's website or reinstall the software from the media provided by the manufacturer.

---

 **IMPORTANT:** Recovery through HP Recovery Manager should be used as a final attempt to correct computer issues.

---

- HP Recovery media must be used if the computer hard drive fails. If you have not already created recovery media, see [Creating HP Recovery media \(select products only\) on page 109](#).
- To use the Factory Reset option (select products only), you must use HP Recovery media. If you have not already created recovery media, see [Creating HP Recovery media \(select products only\) on page 109](#).
- If your computer does not allow the creation of HP Recovery media or if the HP Recovery media does not work, you can obtain recovery media for your system from support. See the *Worldwide Telephone Numbers* booklet included with the computer. You can also find contact information from the HP website. Go to <http://www.hp.com/support>, select your country or region, and follow the on-screen instructions.

---

 **IMPORTANT:** HP Recovery Manager does not automatically provide backups of your personal data. Before beginning recovery, back up any personal data you want to retain.

---

Using HP Recovery media, you can choose from one of the following recovery options:

---

 **NOTE:** Only the options available for your computer display when you start the recovery process.

---

- System Recovery—Reinstalls the original operating system, and then configures the settings for the programs that were installed at the factory.
- Factory Reset—Restores the computer to its original factory state by deleting all information from the hard drive and re-creating the partitions. Then it reinstalls the operating system and the software that was installed at the factory.

The HP Recovery partition (select products only) allows System Recovery only.

### Using the HP Recovery partition (select products only)

The HP Recovery partition allows you to perform a system recovery without the need for recovery discs or a recovery USB flash drive. This type of recovery can be used only if the hard drive is still working.

To start HP Recovery Manager from the HP Recovery partition:

1. Type `recovery` in the taskbar search box, select **Recovery Manager**, and then select **HP Recovery Environment**.

- or -

Press **f11** while the computer boots, or press and hold **f11** as you press the power button.

2. Select **Troubleshoot** from the boot options menu.
3. Select **Recovery Manager**, and then follow the on-screen instructions.

### Using HP Recovery media to recover

You can use HP Recovery media to recover the original system. This method can be used if your system does not have an HP Recovery partition or if the hard drive is not working properly.

1. If possible, back up all personal files.
2. Insert the HP Recovery media, and then restart the computer.

---

 **NOTE:** If the computer does not automatically restart in HP Recovery Manager, change the computer boot order. See [Changing the computer boot order on page 113](#).

---

3. Follow the on-screen instructions.

## Changing the computer boot order

If your computer does not restart in HP Recovery Manager, you can change the computer boot order, which is the order of devices listed in BIOS where the computer looks for startup information. You can change the selection to an optical drive or a USB flash drive.

To change the boot order:

1. Insert the HP Recovery media.
2. Access BIOS.  
Restart the computer, quickly press **esc**, and then press **f9** for boot options.
3. Select the optical drive or USB flash drive from which you want to boot.
4. Follow the on-screen instructions.

## Removing the HP Recovery partition (select products only)

HP Recovery Manager software allows you to remove the HP Recovery partition to free up hard drive space.

 **IMPORTANT:** After you remove the HP Recovery partition, you will not be able to perform System Recovery or create HP recovery media from the HP Recovery partition. So before you remove the Recovery partition, create HP Recovery media; see [Creating HP Recovery media \(select products only\) on page 109](#).

 **NOTE:** The Remove Recovery Partition option is only available on products that support this function.

Follow these steps to remove the HP Recovery partition:

1. Type `recovery` in the taskbar search box, and then select **HP Recovery Manager**.
2. Select **Remove Recovery Partition**, and then follow the on-screen instructions.

# Backing up, restoring, and recovering in Windows 8.1, Windows 8, or Industry 8.1

Your computer includes tools provided by HP and Windows to help you safeguard your information and retrieve it if you ever need to. These tools will help you return your computer to a proper working state or even back to the original factory state, all with simple steps.

This section provides information about the following processes:

- Creating recovery media and backups
- Restoring and recovering your system

 **NOTE:** This section describes an overview of backing up, restoring, and recovering options. For more details about the tools provided, see Help and Support. From the Start screen, type `help`, and then select **Help and Support**.

## Creating recovery media and backups

Recovery after a system failure is only as good as your most recent backup.

1. After you successfully set up the computer, create recovery media. This step creates a backup of the recovery partition on the computer. The backup can be used to reinstall the original operating system in cases where the hard drive is corrupted or has been replaced.

---

 **NOTE:** There is no recovery partition on systems with a 32GB SSD. For those systems, you must use the recovery media in the box or that can be obtained from HP Services.

---

You will use a USB flash drive to create a bootable recovery drive that can be used to troubleshoot a computer that is unable to start. The USB flash drive can be used to reinstall the original operating system and the programs that were installed at the factory.

---

 **NOTE:** Any information on the USB flash drive will be erased before the recovery media is created.

---

- To create the Windows 8.1 or Industry 8.1 recovery media, from the Start screen, type `recovery drive`, then click on **Create a recovery drive**. Follow the on-screen instructions to continue.
  - To create the Windows 8 recovery media, from the Start screen, type `recovery drive`, and then click on **Settings**, then click on **Create a recovery drive**. Follow the on-screen instructions to continue.
2. Use the Windows tools to create system restore points and create backups of personal information. For more information and steps, see Help and Support. From the Start screen, type `help`, and then select **Help and Support**.

## Restoring and recovering using Windows tools

Windows offers several options for restoring from backup, refreshing the computer, and resetting the computer to its original state. For more information and steps, see Help and Support. From the Start screen, type `help`, and then select **Help and Support**.

## Using Reset when the system is not responding

---

 **NOTE:** You may be prompted by User Account Control for your permission or password when you perform certain tasks. To continue a task, select the appropriate option. For information about User Account Control, see Help and Support. From the Start screen, type `help`, and then select **Help and Support**.

---

 **IMPORTANT:** Reset does not provide backups of your information. Before using Reset, back up any personal information you wish to retain.

---

If Windows recovery steps are not working and the system is not responding, use these steps to start Reset:

1. If possible, back up all personal files.
2. If possible, check for the presence of the HP Recovery partition:
  - For Windows 8.1 or Industry 8.1, from the Start screen, type `pc`, and then select **This PC**.
  - For Windows 8, from the Start screen, type `c`, and then select **Computer**.

---

 **NOTE:** If the HP Recovery partition is not listed, or you cannot check for its presence, you must recover using the recovery media you created; see [Recovery using the Windows recovery USB flash drive on page 115](#). Or you must use the Windows operating system media and the *Driver Recovery* media (purchased separately); see [Recovery using Windows operating system media \(purchased separately\) on page 115](#).

---

3. If the HP Recovery partition is listed, restart the computer, and then press `esc` while the HP logo is displayed. The computer Startup Menu displays.
4. Press `f11` to select the System Recovery option.
5. Choose your keyboard layout.
6. Select **Troubleshoot**.

7. Select **Reset**.
8. Follow the on-screen instructions to continue.

## Recovery using the Windows recovery USB flash drive

To recover your system using the recovery USB flash drive you previously created:

---

 **NOTE:** If you did not create a recovery USB flash drive or the one you created does not work, see [Recovery using Windows operating system media \(purchased separately\) on page 115](#).

---

1. If possible, back up all personal files.
2. Insert the recovery USB flash drive you created into a USB port on your computer.
3. Restart the computer and as soon as you see the HP logo screen, press **f9** to display a list of boot devices. Use the arrow keys to select your USB flash drive from the UEFI Boot Sources list. Press **Enter** to boot from that device.
4. Choose your keyboard layout.
5. Select **Troubleshoot**.
6. Select **Refresh your PC**.
7. Follow the on-screen instructions.

## Recovery using Windows operating system media (purchased separately)

To order a Windows operating system DVD, contact support. Go to <http://www.hp.com/support>, select your country or region, and follow the on-screen instructions.

---

 **CAUTION:** Using Windows operating system media completely erases the hard drive contents and reformats the hard drive. All files that you have created and any software that you have installed on the computer are permanently removed. When reformatting is complete, the recovery process helps you restore the operating system, as well as drivers, software, and utilities.

---

To initiate recovery using Windows operating system media:

---

 **NOTE:** This process takes several minutes.

---

1. If possible, back up all personal files.
2. Restart the computer, and then follow the instructions provided with the Windows operating system media to install the operating system.
3. When prompted, press any keyboard key.
4. Follow the on-screen instructions.

After the repair is completed and the Windows desktop appears:

1. Remove the Windows operating system media, and then insert the *Driver Recovery* media.
2. Install the Hardware Enabling Drivers first, and then install Recommended Applications.

# Backing up, restoring, and recovering in Windows 7 and POSReady 7

Your computer includes tools provided by HP and Windows to help you safeguard your information and retrieve it if you ever need to. These tools will help you return your computer to a proper working state or even back to the original factory state, all with simple steps.

This section provides information about the following processes:

- Creating recovery media and backups
- Restoring and recovering your system



**NOTE:** This section describes an overview of backing up, restoring, and recovering options. For more details about the Windows Backup and Restore tools provided, see Help and Support. To access Help and Support, select **Start > Help and Support**.

Recovery after a system failure is only as good as your most recent backup.

1. After you successfully set up the computer, create recovery media. This media can be used to reinstall the original operating system in cases where the hard drive is corrupted or has been replaced. See [Creating recovery media on page 116](#).
2. As you add hardware and software programs, create system restore points. A system restore point is a snapshot of certain hard drive contents saved by Windows System Restore at a specific time. A system restore point contains information that Windows uses, such as registry settings. Windows creates a system restore point for you automatically during a Windows update and during other system maintenance (such as a software update, security scanning, or system diagnostics). You can also manually create a system restore point at any time. For more information and steps for creating specific system restore points, see Help and Support. To access Help and Support, select **Start > Help and Support**.
3. As you add photos, video, music, and other personal files, create a backup of your personal information. If files are accidentally deleted from the hard drive and they can no longer be restored from the Recycle Bin, or if files become corrupted, you can restore the files that you backed up. In case of system failure, you can use the backup files to restore the contents of your computer. See [Backing up your information on page 118](#).



**NOTE:** HP recommends that you print the recovery procedures and save them for later use, in case of system instability.

## Creating recovery media

After you successfully set up the computer, create recovery media. The media can be used to reinstall the original operating system in cases where the hard drive is corrupted or has been replaced.

There are two types of recovery media. To determine which steps to follow for your computer:

1. Click the **Start** button.
2. Click **All Programs**.
  - If **Security and Protection** is listed, continue with the steps in [Creating recovery media using HP Recovery Manager \(select models only\) on page 117](#).
  - If **Productivity and Tools** is listed, continue with the steps in [Creating recovery discs with HP Recovery Disc Creator \(select models only\) on page 117](#).

## Creating recovery media using HP Recovery Manager (select models only)

- To create recovery discs, your computer must have a DVD writer. Use DVD+R or DVD-R discs (purchased separately). The discs you use will depend on the type of optical drive you are using.

---

 **NOTE:** DVD+R DL, DVD-R DL, or DVD±RW disc are not supported.

---

- You have the option of creating a recovery USB flash drive instead, using a high-quality USB drive.
- If you are creating recovery discs, be sure to use high-quality discs. It is normal for the system to reject defective discs. You will be prompted to insert a new blank disc to try again.
- The number of discs in the recovery-disc set depends on your computer model (typically 3 to 6 DVDs). The Recovery Media Creation program tells you the specific number of blank discs needed to make the set. If you are using a USB flash drive, the program will tell you the size of the drive required to store all the data (minimum of 8 GB).

---

 **NOTE:** The process of creating recovery media is lengthy. You can quit the process at any time. The next time you initiate the process, it resumes where it left off.

---

 **NOTE:** Do not use media cards for creating recovery media. The system may not be able to boot up from a media card and you may not be able to run system recovery.

---

To create recovery discs:

1. Close all open programs.
2. Click the **Start** button, click **All Programs**, click **Security and Protection**, click **Recovery Manager**, and then click **HP Recovery Media Creation**. If prompted, click **Yes** to allow the program to continue.
3. Click **Create recovery media using blank DVD(s)**, and then click **Next**.
4. Follow the on-screen instructions. Label each disc after you make it (for example, Recovery 1, Recovery 2), and then store the discs in a secure place.

To create a recovery USB flash drive:

---

 **NOTE:** You must use a USB flash drive with a capacity of at least 8 GB.

---

 **NOTE:** Recovery Media Creation formats the USB flash drive, deleting any files on it.

---

1. Close all open programs.
2. Insert the USB flash drive into a USB port on the computer.
3. Click the **Start** button, click **All Programs**, click **Security and Protection**, click **Recovery Manager**, and then click **Recovery Media Creation**.
4. Click **Create recovery media with a USB flash drive**, and then click **Next**.
5. Select the USB flash drive from the list of media. The program will let you know how much storage is required to create the recovery drive. If the USB flash drive does not have enough storage capacity, it will appear grayed out, and you must replace it with a larger USB flash drive. Click **Next**.
6. Follow the on-screen instructions. When the process is complete, label the USB flash drive and store it in a secure place.

## Creating recovery discs with HP Recovery Disc Creator (select models only)

HP Recovery Disc Creator is a software program that offers an alternative way to create recovery discs on select models. After you successfully set up the computer, you can create recovery discs using HP Recovery Disc Creator. The recovery discs allow you to reinstall your original operating system as well as select drivers

and applications if the hard drive becomes corrupted. HP Recovery Disc Creator creates two kinds of recovery discs:

- Operating system DVD—Installs the operating system without additional drivers or applications.
- *Driver Recovery* DVD—Installs specific drivers and applications only, in the same way that the HP Software Setup utility installs drivers and applications.

To create recovery discs, your computer must have a DVD writer. Use any of the following types of discs (purchased separately): DVD+R, DVD+R DL, DVD-R, DVD-R DL, or DVD±RW. The discs you use will depend on the type of optical drive you are using.

## Creating recovery discs



**NOTE:** The operating system DVD can be created only once. The option to create that media will not be available after you create a Windows DVD.

To create the Windows DVD:

1. Select **Start > All Programs > Productivity and Tools > HP Recovery Disc Creator**.
2. Select **Windows disk**.
3. From the drop-down menu, select the drive for burning the recovery media.
4. Click the **Create** button to start the burning process. Label the disc after you create it, and store it in a secure place.

After the Windows 7 operating system DVD has been created, create the *Driver Recovery* DVD:

1. Select **Start > All Programs > Productivity and Tools > HP Recovery Disc Creator**.
2. Select **Driver disk**.
3. From the drop-down menu, select the drive for burning the recovery media.
4. Click the **Create** button to start the burning process. Label the disc after you create it, and store it in a secure place.

## Backing up your information

You should create your initial backup immediately after initial system setup. As you add new software and data files, you should continue to back up your system on a regular basis to maintain a reasonably current backup. Your initial and subsequent backups allow you to restore your data and settings if a failure occurs.

You can back up your information to an optional external hard drive, a network drive, or discs.

Note the following when backing up:

- Store personal files in the Documents library, and back it up regularly.
- Back up templates that are stored in their associated directories.
- Save customized settings that appear in a window, toolbar, or menu bar by taking a screen shot of your settings. The screen shot can be a time-saver if you have to reset your preferences.
- When backing up to discs, number each disc after removing it from the drive.



**NOTE:** For detailed instructions on various backup and restore options, perform a search for these topics in Help and Support. To access Help and Support, select **Start > Help and Support**.



 **NOTE:** You may be prompted by User Account Control for your permission or password when you perform certain tasks. To continue a task, select the appropriate option. For information about User Account Control, see Help and Support: Select **Start > Help and Support**.

---

To create a backup using Windows Backup and Restore:

 **NOTE:** The backup process may take over an hour, depending on file size and the speed of the computer.

---

1. Select **Start > All Programs > Maintenance > Backup and Restore**.
2. Follow the on-screen instructions to set up your backup.

## System Restore

If you have a problem that might be due to software that you installed on your computer, or if you want to restore the system to a previous state without losing any personal information, use System Restore to return the computer to a previous restore point.

 **NOTE:** Always use this System Restore procedure before you use the System Recovery feature.

---

To start System Restore:

1. Close all open programs.
2. Click the **Start** button, right-click **Computer**, and then click **Properties**.
3. Click **System protection, System Restore**, click **Next**, and then follow the on-screen instructions.

## System Recovery

 **WARNING!** This procedure will delete all user information. To prevent loss of information, be sure to back up all user information so you can restore it after recovery.

---

System Recovery completely erases and reformats the hard disk drive, deleting all data files that you have created, and then reinstalls the operating system, programs, and drivers. However, you must reinstall any software that was not installed on the computer at the factory. This includes software that came on media included in the computer accessory box, and any software programs you installed after purchase. Any personal files must be restored from backups you made.

If you were not able to create system recovery DVDs or USB flash drive, you can order a recovery disc set from support. Go to <http://www.hp.com/support>, select your country or region, and follow the on-screen instructions.

 **NOTE:** Always use the System Restore procedure before you use the System Recovery program. See [System Restore on page 119](#).

---

You must choose one of the following methods to perform a System Recovery:

- Recovery image — Run System Recovery from a recovery image stored on your hard disk drive. The recovery image is a file that contains a copy of the original factory-shipped software. To perform a System Recovery from a recovery image, see [System Recovery when Windows is responding on page 120](#) or [System Recovery when Windows is not responding on page 120](#).
- Recovery media — Run System Recovery from recovery media that you have created from files stored on your hard disk drive or purchased separately. See [System Recovery using recovery media \(select models only\) on page 121](#).

## System Recovery when Windows is responding

---

 **CAUTION:** System Recovery deletes all data and programs you created or installed. Before you begin, back up any important data to a CD or DVD or to a USB flash drive.

 **NOTE:** In some cases, you must use recovery media for this procedure. If you have not already created this media, follow the instructions in [Creating recovery media on page 116](#).

---

If the computer is working and Windows 7 is responding, use these steps to perform a System Recovery:

1. Turn off the computer.
2. Disconnect all peripheral devices from the computer except the monitor, keyboard, and mouse.
3. Turn on the computer.
4. When Windows has loaded, click the **Start** button, and then click **All Programs**.
  - If **Security and Protection** is listed, continue with step 5.
  - If **Productivity and Tools** is listed, follow the steps in [System Recovery when Windows is not responding on page 120](#).
5. Click **Security and Protection**, click **Recovery Manager**, and then click **Recovery Manager**. If prompted, click **Yes** to allow the program to continue.
6. Under **I need help immediately**, click **System Recovery**.
7. Select **Yes**, and then click **Next**. Your computer restarts.
8. When the computer restarts, you will see the Recovery Manager welcome screen again. Under **I need help immediately**, click **System Recovery**. If you are prompted to back up your files, and you have not done so, select **Back up your files first (recommended)**, and then click **Next**. Otherwise, select **Recover without backing up your files**, and then click **Next**.
9. System Recovery begins. After System Recovery is complete, click **Finish** to restart the computer.
10. When Windows has loaded, shut down the computer, reconnect all peripheral devices, and then turn the computer back on.

## System Recovery when Windows is not responding

---

 **CAUTION:** System Recovery deletes all data and programs you created or installed.

---

If Windows is not responding, but the computer is working, follow these steps to perform a System Recovery.

1. Turn off the computer. If necessary, press and hold the power button until the computer turns off.
2. Disconnect all peripheral devices from the computer, except the monitor, keyboard, and mouse.
3. Press the power button to turn on the computer.
4. As soon as you see the HP logo screen, repeatedly press the **F11** key on your keyboard until the *Windows is Loading Files...* message appears on the screen.
5. At the HP Recovery Manager screen, follow the on-screen instructions to continue.
6. When Windows has loaded, shut down the computer, reconnect all peripheral devices, and then turn the computer back on.

## System Recovery using recovery media (select models only)

Use the steps provided in this section if you created recovery media using [Creating recovery media using HP Recovery Manager \(select models only\) on page 117](#). If you used HP Recovery Disc Creator to create a Windows 7 operating system DVD and a *Driver Recovery* DVD, use the steps in [Using HP Recovery Disc operating system discs \(select models only\) on page 121](#).

---

 **CAUTION:** System Recovery deletes all data and programs you have created or installed. Back up any important data to a CD or DVD or to a USB flash drive.

---

To perform a System Recovery using recovery media:

1. If you are using a set of DVDs, insert the first recovery disc into the DVD drive tray, and close the tray. If you are using a recovery USB flash drive, insert it into a USB port.
2. Click the **Start** button, and then click **Shut Down**.

**or**

- If the computer is not responding, press and hold the power button for approximately 5 seconds or until the computer turns off.
3. Disconnect all peripheral devices from the computer except the monitor, keyboard, and mouse.
  4. Press the power button to turn on the computer, and press **Esc** as the computer is powering on to display the startup menu.
  5. Use the arrow keys to select the boot menu, and press **Enter**. Use the arrow keys to select the location where the recovery media is inserted (USB or DVD). Press **Enter** to boot from that device.
  6. If Recovery Manager asks if you want to run System Recovery from Media or Hard Drive, select **Media**. On the Welcome screen, under **I need help immediately**, click **Factory Reset**.
  7. If you are prompted to back up your files, and you have not done so, select **Back up your files first (recommended)**, and then click **Next**. Otherwise, select **Recover without backing up your files**, and then click **Next**.
  8. If you are prompted to insert the next recovery disc, do so.
  9. When Recovery Manager is finished, remove the recovery disc or the recovery USB flash drive from the system.
  10. Click **Finish** to restart the computer.

## Using HP Recovery Disc operating system discs (select models only)

Use the steps provided in this section if you used HP Recovery Disc Creator to create an operating system DVD and a *Driver Recovery* DVD. If you created recovery media using [Creating recovery media using HP Recovery Manager \(select models only\) on page 117](#), use the steps in [System Recovery using recovery media \(select models only\) on page 121](#).

If you cannot use the recovery discs you previously created using the HP Recovery Disc Creator (select models only), you must purchase an operating system DVD to reboot the computer and repair the operating system.

To order an operating system DVD, contact support. Go to <http://www.hp.com/support>, select your country or region, and follow the on-screen instructions.

---

 **CAUTION:** Using a Windows 7 or POSReady operating system DVD completely erases the hard drive contents and reformats the hard drive. All files that you have created and any software that you have installed on the computer are permanently removed. When reformatting is complete, the recovery process helps you restore the operating system, as well as drivers, software, and utilities.

---

To initiate recovery using a Windows 7 or POSReady operating system DVD:



---

**NOTE:** This process takes several minutes.

---

1. If possible, back up all personal files.
2. Restart the computer, and then insert the operating system DVD into the optical drive before the Windows operating system loads.



---

**NOTE:** If the computer does not boot to the DVD, restart the computer and press **Esc** as the computer is powering on to see the startup menu. Use the arrow keys to select the boot menu and press **Enter**. Use the arrow keys to select the location where the recovery DVD is inserted. Press **Enter** to boot from that device.

---

3. When prompted, press any keyboard key.
4. Follow the on-screen instructions.
5. Click **Next**.
6. Select **Install now**.
7. Follow the on-screen instructions.

After the repair is completed:

1. Eject the operating system DVD and then insert the *Driver Recovery* DVD.
2. Follow the on-screen instructions to install the Hardware Enabling Drivers first, and then install Recommended Applications.

---

# A Power cord set requirements

The power supplies on some computers have external power switches. The voltage select switch feature on the computer permits it to operate from any line voltage between 100-120 or 220-240 volts AC. Power supplies on those computers that do not have external power switches are equipped with internal switches that sense the incoming voltage and automatically switch to the proper voltage.

The power cord set received with the computer meets the requirements for use in the country where you purchased the equipment.

Power cord sets for use in other countries must meet the requirements of the country where you use the computer.

## General requirements

The requirements listed below are applicable to all countries:

1. The power cord must be approved by an acceptable accredited agency responsible for evaluation in the country where the power cord set will be installed.
2. The power cord set must have a minimum current capacity of 10A (7A Japan only) and a nominal voltage rating of 125 or 250 volts AC, as required by each country's power system.
3. The diameter of the wire must be a minimum of 0.75 mm<sub>2</sub> or 18AWG, and the length of the cord must be between 1.8 m (6 feet) and 3.6 m (12 feet).

The power cord should be routed so that it is not likely to be walked on or pinched by items placed upon it or against it. Particular attention should be paid to the plug, electrical outlet, and the point where the cord exits from the product.

---

 **WARNING!** Do not operate this product with a damaged power cord set. If the power cord set is damaged in any manner, replace it immediately.

---

## Japanese power cord requirements

For use in Japan, use only the power cord received with this product.

---

 **CAUTION:** Do not use the power cord received with this product on any other products.

---

## Country-specific requirements

Additional requirements specific to a country are shown in parentheses and explained below.

Country	Accrediting Agency	Country	Accrediting Agency
Australia (1)	EANSW	Italy (1)	IMQ
Austria (1)	OVE	Japan (3)	METI
Belgium (1)	CEBC	Norway (1)	NEMKO
Canada (2)	CSA	Sweden (1)	SEMKO
Denmark (1)	DEMKO	Switzerland (1)	SEV
Finland (1)	SETI	United Kingdom (1)	BSI
France (1)	UTE	United States (2)	UL
Germany (1)	VDE		

1. The flexible cord must be Type H05VV-F, 3-conductor, 0.75mm<sup>2</sup> conductor size. Power cord set fittings (appliance coupler and wall plug) must bear the certification mark of the agency responsible for evaluation in the country where it will be used.
2. The flexible cord must be Type SVT or equivalent, No. 18 AWG, 3-conductor. The wall plug must be a two-pole grounding type with a NEMA 5-15P (15A, 125V) or NEMA 6-15P (15A, 250V) configuration.
3. Appliance coupler, flexible cord, and wall plug must bear a “T” mark and registration number in accordance with the Japanese Dentori Law. Flexible cord must be Type VCT or VCTF, 3-conductor, 0.75 mm<sup>2</sup> conductor size. Wall plug must be a two-pole grounding type with a Japanese Industrial Standard C8303 (7A, 125V) configuration.

# B Specifications

---

---

<b>Temperature Range</b>		
Operating	50° to 95°F	10° to 35°C
Nonoperating	-22° to 140°F	-30° to 60°C

---

**NOTE:** Operating temperature is derated 1.0° C per 300 m (1000 ft) to 3000 m (10,000 ft) above sea level; no direct sustained sunlight. Maximum rate of change is 10° C/Hr. The upper limit may be limited by the type and number of options installed.

---

<b>Relative Humidity (noncondensing)</b>		
Operating	10-90%	10-90%
Nonoperating (38.7°C max wet bulb)	5-95%	5-95%

---

<b>Maximum Altitude (unpressurized)</b>		
Operating	10,000 ft	3048 m
Nonoperating	30,000 ft	9144 m

---

<b>Power Supply</b>	
	180W
Rated Line Frequency	50-60 Hz
Operating Line Frequency	47-63 Hz

---

- <sup>1</sup> This system utilizes an active power factor corrected power supply. This allows the system to pass the CE mark requirements for use in the countries of the European Union. The active power factor corrected power supply also has the added benefit of not requiring an input voltage range select switch.
- <sup>2</sup> High efficiency power supply is a requirement for ENERGY STAR® qualification in conjunction with a select range of processors and modules.

# Index

- A**
  - access panel
    - locked 92
  - antennas
    - illustrated 8
    - removal and replacement 52
  - audible codes 79
  - audio problems 97
- B**
  - backup and recovery, Windows 7 116
  - Backup and Restore, Windows 7 119
  - backups
    - creating Windows 7 116, 118
  - barcode scanner
    - installation 29
  - battery
    - disposal 17
    - removing and installing 41
  - beep codes 79
  - biometric reader
    - installation 29
  - booting options
    - Full Boot 74
    - Quick Boot 74
- C**
  - cable management 18
  - cable pinouts, SATA data 18
  - cautions
    - AC power 11
    - cables 17
    - cooling fan 16
    - electrostatic discharge 11
  - CFD, illustrated 7
  - changing a Power-On password 82
  - changing a Setup password 82
  - cleaning
    - computer 14
  - CMOS
    - backing up 81
    - clearing and resetting 83
  - compact stand
    - removing and replacing 21
    - routing cables 24
  - computer cleaning 14
  - Computer Setup
    - access problem 90
  - country power cord set
    - requirements 124
  - customer facing display (CFD)
    - installation 32
  - Customer Support 87
- D**
  - deleting a Power-On password 83
  - deleting a Setup password 83
  - disassembly preparation 19
  - display (2x20), illustrated 7
  - display panel
    - illustrated 6
  - display panel assembly
    - removal and replacement 57
  - Driver Recovery DVD,
    - creating 117
    - using for restore 121
  - Driver Recovery media, Windows 115
  - Driver Recovery media, Windows 8.1 115
- E**
  - electrostatic discharge (ESD) 11
    - preventing damage 12
  - ergonomic stand
    - power supply removal and replacement 25
    - removing and replacing 21
    - routing cables 24
    - unfolding 3
  - error
    - codes 74, 79
    - messages 74
- F**
  - F10 Setup
    - access problem 90
  - f11 recovery, Windows 8 114
  - f11 recovery, Windows 8.1 114
  - fan
    - illustrated 10
    - removal and replacement 48
  - fan, power supply 16
  - features 1
  - flash drive problems 105
  - flashing LEDs 79
- G**
  - general problems 90
  - grounding methods 12
- H**
  - hard drive
    - illustrated 9
    - proper handling 17
    - removing and installing 37
    - SATA characteristics 17
  - hard drive bracket
    - removal and replacement 43
  - hard drive connector and cable
    - illustrated 8
  - hard drive problems 94
  - hard drive recovery
    - Windows 114
    - Windows 7 119
    - Windows 8.1 114
  - hard drives 7
  - hardware installation problems 100
  - heat sink
    - illustrated 10
    - removing 46
  - Help and Support
    - Windows 7 116
  - helpful hints 88
  - HP PC Hardware Diagnostics (UEFI)
    - using 85
  - HP Recovery Disc Creator, using 117
- I**
  - integrated USB peripherals
    - configuring 61
    - installing 29, 32



Internet access problems 106

## M

M.2 storage device

removing and installing 39

magnetic strip reader (MSR)

installation 29

memory

problems 104

removing and installing 35

specifications 35

memory modules

illustrated 6

MSR, illustrated 7

## N

network problems 101

numeric error codes 74

## O

operating system media, Windows 8 115

operating system media, Windows 8.1 115

## P

password

clearing 81

power-on 81

setup 81

passwords 82, 83

port cover 20

POST error messages 74

power board

illustrated 10

removal and replacement 59

power board cable

illustrated 8

power cord set requirements

country specific 124

power supply

fan 16

illustrated 6

operating voltage range 125

Power-On password 82, 83

power-on password 81

printer problems 99

problems

audio 97

Computer Setup 90

F10 Setup 90

flash drive 105

general 90

hard drive 94

hardware installation 100

Internet access 106

memory 104

network 101

printer 99

retail system 89

software 108

processor

removing 47

## R

rear components 4

rear cover

illustrated 5

removing 28

rear plastic trim

illustrated 5

rear trim

removal and replacement 49

recovery discs, steps for creating

Windows 7 117

recovery discs, using for restore

121

recovery media, creating 117

recovery media, creating Windows

7 116

recovery partition, Windows 8 114

recovery partition, Windows 8.1

114

recovery USB flash drive, steps for

creating Windows 7 117

recovery using Windows 8 operating

system media 115

recovery using Windows 8.1

operating system media 115

removal and replacement

antennas 52

display panel assembly 57

fan 48

hard drive bracket 43

power board 59

rear trim 49

speakers 51

system board 53

VESA mount bracket 44

removal and replacement procedures

heat sink 46

processor 47

rear cover 28

shield 28

thermal module 46

WLAN module 42

removing

USB port 50

resetting

CMOS 81

password jumper 81

restoring the hard drive, Windows

114

restoring the hard drive, Windows

8.1 114

## S

safety and comfort 87

safety precautions

cleaning 13

SATA

connectors on system board 17

data cable pinouts 18

hard drive characteristics 17

screws, correct size 16

serial ports, configuring for power

61

service considerations 16

Setup password 82, 83

setup password 81

shield

removing 28

software

problems 108

servicing computer 16

solid-state drive

illustrated 9

speakers

illustrated 10

removal and replacement 51

specifications

computer 125

static electricity 11

system board

illustrated 5

removal and replacement 53

SATA connectors 17

System Recovery using Windows 7

recovery media 121

System Recovery, Windows 7 119

- system restore points, creating
  - Windows 7 116
- System Restore, Windows 7 119

## T

- tamper-proof screws
  - tool 16
- thermal module
  - removing 46
- tools, servicing 16
- Torx T15 screwdriver 16
- touch screen
  - calibration 60
- transceivers
  - illustrated 8
- trim
  - illustrated 5

## U

- USB port
  - illustrated 10
  - removal 50

## V

- VESA cover
  - illustrated 6
- VESA mount bracket
  - removal and replacement 44

## W

- wall mount 21
- webcam
  - installation 29
- webcam, illustrated 7
- Windows 10
  - backup and restore 109
- Windows 7
  - backing up information 118
  - backup and recovery 116
  - Backup and Restore 119
  - creating backups 116
  - creating recovery media 116
  - creating system restore points 116
  - hard drive recovery 119
  - Help and Support 116
  - steps for creating recovery discs 117
  - steps for creating recovery media 117

- steps for creating recovery USB flash drive 117
- System Recovery 119
- System Recovery using recovery media 121
- System Restore 119
- Windows 7 operating system discs
  - using for restore 121
- Windows 7 operating system DVD
  - creating 117
  - using for restore 121
- Windows 7 operating system media
  - creating 117
- Windows 8
  - backup and restore 113
  - Driver Recovery media 115
  - f11 recovery 114
  - hard drive recovery 114
  - operating system DVD 115
  - recovery partition 114
  - restoring the hard drive 114
- Windows 8.1
  - backup and restore 113
  - Driver Recovery media 115
  - f11 recovery 114
  - hard drive recovery 114
  - operating system DVD 115
  - recovery partition 114
  - restoring the hard drive 114
- WLAN module
  - illustrated 10
  - removing 42