

IF₂

Network Reader

Model 1009FF01



User Manual

Intermec by Honeywell
6001 36th Ave. W.
Everett, WA 98203
U.S.A.

www.intermec.com

The information contained herein is provided solely for the purpose of allowing customers to operate and service Intermec-manufactured equipment and is not to be released, reproduced, or used for any other purpose without written permission of Intermec by Honeywell.

Information and specifications contained in this document are subject to change without prior notice and do not represent a commitment on the part of Intermec by Honeywell.

© 2011–2014 Intermec by Honeywell. All rights reserved.

The word Intermec, the Intermec logo, and Ready-to-Work are either trademarks or registered trademarks of Intermec by Honeywell.

For patent information, please refer to www.honeywellaidc.com/patents

This product includes copyrighted software that is licensed under GPL v2 (www.gnu.org/licenses/old-licenses/gpl-2.0.html) or LGPL v2.1 (www.gnu.org/licenses/lgpl-2.1.html). You may obtain the complete Corresponding Source code from Intermec (www.intermec.com) for a period of three years after Intermec's last shipment of this product. This offer is valid to anyone in receipt of this information.

There are U.S. and foreign patents as well as U.S. and foreign patents pending.

This product includes cryptographic software written by Eric Young (EAY@cryptsoft.com).

Part of the software embedded in this product is gSOAP software. Portions created by gSOAP are Copyright (C) 2001–2004 Robert A. van Engelen, Genivia inc. All Rights Reserved.

In no event shall the author be liable for any direct, indirect, incidental, special, exemplary, or consequential damages (including, but not limited to, procurement of substitute goods or services; loss of use, data, or profits; or business interruption) however caused and on any theory of liability, whether in contract, strict liability, or tort (including negligence or otherwise) arising in any way out of the use of this software, even if advised of the possibility of such damage.

ACE(TM), TAO(TM), CIAO(TM), and CoSMIC(TM) (henceforth referred to as “DOC software”) are copyrighted by Douglas C. Schmidt and his research group at Washington University, University of California, Irvine, and Vanderbilt University, Copyright (c) 1993–2006, all rights reserved.

Document Change Record

This page records changes to this document. The document was originally released as Revision 001.

Version Number	Date	Description of Change
002	3/2014	Revised to support the IF2 with expanded memory option.

Contents

Before You Begin.....	xi
Safety Information.....	xi
Global Services and Support.....	xii
Warranty Information.....	xii
Web Support.....	xii
Send Feedback.....	xii
Telephone Support.....	xii
Who Should Read This Manual.....	xiii
Related Documents.....	xiii

1 About the RFID Reader 1

About the IF2.....	2
About the LEDs.....	3
About the Ready-to-Work Indicator.....	5
About the Network and Power Ports.....	5
About the Top Panel Ports.....	7
How to Communicate with the IF2.....	8
Assign an Initial IP Address.....	8
Use the Web Browser Interface.....	11
Save Configuration Changes.....	13
Disable Help in the Web Browser Interface.....	13
Install the IF2.....	15
Connect the IF2 to Your Network.....	16
Set the Date and Time.....	18
How to Use the IF2 Securely.....	19

2 Configure Network Settings 21

Configure the Settings for Your Network.....	22
Configure Ethernet Settings.....	22
Configure Common Network Settings.....	25

Contents

Configure Security	26
Control Access Services	27
Set Up Logins	28
Configure the IF2 to Use a Password Server	29
Change the Default Login	31
Disable Access Through the Serial Port	32
Manage Certificates	33
View Certificates	34
Install and Uninstall Certificates	35

3 Develop and Use RFID Applications 37

About the IF2 Configurations	38
RFID Applications and the IF2	38
Use the RFID Resource Kit	39
Create RFID Applications	39
About RFID Services	39
Configure BRI Settings	40
Change BRI Attribute Settings	40
About BRI Attribute Settings	41
Tag Types	41
Read Tries	41
Write Tries	41
Lock Tries	41
Field Separator	42
ID Report	42
No Tag Report	42
Report Timeout	42
Timeout Configuration Mode	42
Select Tries	43
Unselect Tries	43
Session	43
Initial Q	43
Initialization Tries	43
Schedule Option	44
ID Tries	44
Antenna Tries	44
EPCC1G2 Advance Medium Access Mode	44
Dense Reader Mode	44
Antenna Field Strength 1 to 4	45

Antenna Sequence: First through Eighth.....	45
Configure the BRI Server	45
View the BRI Server Log	46
Configure LLRP Settings	48
4 Install Applications on the IF2 with Expanded Memory Option ..	51
Create a Configuration File	52
Auto-Start Applications at Boot Time.	53
About .NET Support	53
About Java Support	53
Execute Java Applications.....	54
Java Support for Microsoft SQL Server and Sybase.....	55
Install RFID Applications.....	55
Manage Applications.....	56
About the Edgeware Applications	57
Upgrade or Install Edgeware Applications.....	57
About the Developer Tools.....	58
Test the GPIO Interfaces.....	58
Send BRI Commands and Running Scripts.....	59
Use the Workbench	59
5 Manage, Troubleshoot, and Upgrade the IF2	61
Manage the IF2	62
Use the Device Configuration Web Service	62
Open a Serial or USB Connection to the IF2.....	64
Open a Serial Connection to the IF2.....	65
Open a USB Connection to the IF2	66

Contents

Maintain the IF2	68
View the System Log	68
View the About Screen	69
Use the LEDs to Locate the IF2	70
Restore the IF2 to the Default Configuration	70
Restore Default Settings with the Web Browser	71
Restore Default Settings with the Reset Switch	72
Restoring Default Settings with a Serial Connection	72
Reboot the IF2	73
Troubleshoot the IF2	74
Problems While Working with RFID	74
Connect Directly to the RFID Module	75
Problems With Connectivity	77
Call Intermec Product Support	78
Access Web Pages	78
Upgrade Firmware	79
Configure the Firmware Upgrade	80
Install the Firmware Upgrade	81
Upgrade From the Web Browser Interface	81
6 Use the IF2 GPIO Interfaces	83
About the GPIO Interfaces	84
Access the Interfaces	84
Use the Input Interfaces	85
IF2 Powered Input	85
Isolated Input Interface	86
Open Collector Input Interface	86
Use the Output Interfaces	87
Switch the High Side With IF2 Power	88
Switch the Low Side With IF2 Power	88
Switching the High Side With External Power	89
Drive a DC Relay to Control an AC Load	89
Use the Power Interface	90

A Specifications	91
IF2 Specifications	92
RFID Specifications	93
Port Pin Assignments	94
GPIO Port	94
Serial Ports (COM1)	95
Ethernet Port	96
I Index	97

Before You Begin

This section provides you with safety information, technical support information, and sources for additional product information.

This section provides you with safety information, technical support information, and sources for additional product information.

Safety Information

Your safety is extremely important. Read and follow all warnings and cautions in this document before handling and operating Intermec equipment. You can be seriously injured, and equipment and data can be damaged if you do not follow the safety warnings and cautions.

This section explains how to identify and understand warnings, cautions, and notes that are in this document.



A warning alerts you of an operating procedure, practice, condition, or statement that must be strictly observed to avoid death or serious injury to the persons working on the equipment.



A caution alerts you to an operating procedure, practice, condition, or statement that must be strictly observed to prevent equipment damage or destruction, or corruption or loss of data.



Note: Notes either provide extra information about a topic or contain special instructions for handling a particular condition or set of circumstances.

Global Services and Support

Warranty Information

To understand the warranty for your Intermec product, visit the Intermec web site at www.intermec.com and click **Support** > **Returns and Repairs** > **Warranty**.

Disclaimer of warranties: The sample code included in this document is presented for reference only. The code does not necessarily represent complete, tested programs. The code is provided “as is with all faults.” All warranties are expressly disclaimed, including the implied warranties of merchantability and fitness for a particular purpose.

Web Support

Visit the Intermec web site at www.intermec.com to download our current manuals (in PDF).

Visit the Intermec technical knowledge base (Knowledge Central) at www.intermec.com and click **Support** > **Knowledge Central** to review technical information or to request technical support for your Intermec product.

Send Feedback

Your feedback is crucial to the continual improvement of our documentation. To provide feedback about this manual, please contact the Intermec Technical Communications department directly at TechnicalCommunications@intermec.com.

Telephone Support

In the U.S.A. and Canada, call **1-800-755-5505**.

Outside the U.S.A. and Canada, contact your local Intermec representative. To search for your local representative, from the Intermec web site, click **About Us** > **Contact Us**.

Who Should Read This Manual

This user's manual is for the person who is responsible for installing, configuring, and maintaining the IF2 Network Reader.

This manual provides you with information about the features of the IF2, and how to install, configure, operate, maintain, and troubleshoot it.

Before you work with the IF2, you should be familiar with your network and general networking terms, such as IP address. You should also be familiar with your RFID system.

Related Documents

This is a list of IF2 related documents:

- *Basic Reader Interface Programmer's Reference Manual*
- *Device Configuration Web Services Command Reference Manual*
- *Low-Level Reader Protocol Programmer's Reference Manual*

The Intermec web site at www.intermec.com contains our documents (as PDF files) that you can download for free.

To download documents

- 1 Visit the Intermec web site at www.intermec.com.
- 2 Click **Products** tab.
- 3 Using the **Products** menu, navigate to your product page. For example, to find the IF2 RFID reader, click **RFID > Network Readers > IF2**.

1

About the RFID Reader

This chapter introduces the IF2 Network Reader, explains the ports and LEDs, and explains how the reader fits into your network. It contains these topics:

- **About the IF2**
- **How to Communicate with the IF2**
- **Install the IF2**
- **Set the Date and Time**
- **How to Use the IF2 Securely**

About the IF2

The IF2 Network Reader is an RFID reader that provides connectivity between tag data and an enterprise system.



IF2 Network Reader



Note: The IF2 does not ship with RFID antennas. For more information on these accessories, contact your sales representative.

The IF2 comes in a standard configuration with no internal memory, or an expanded memory option.

- For the standard IF2, the applications you develop resides on a remote server which communicates with the reader, and all information processing is processed through the server.
- For the IF2 with Expanded Memory Option, the applications you develop can be hosted and run locally on the reader.

The reader forwards RFID tag data to the Ethernet network as shown in the next illustration.

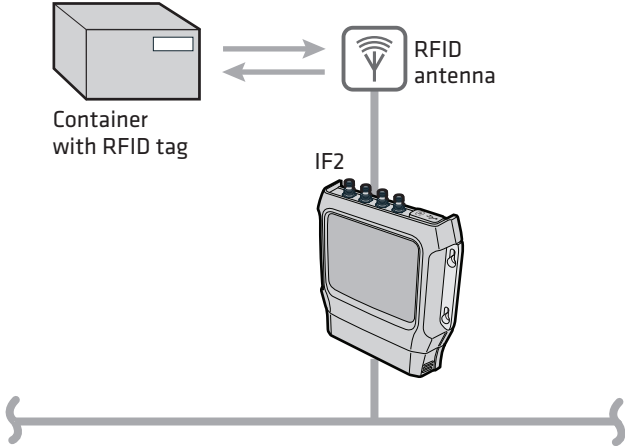

IF2 in a Wired Ethernet Network





About the LEDs

The IF2 has six LEDs that indicate the status of the reader during operation. Use the next table to identify the LED icons on the front panel of the IF2.

IF2 LED Descriptions

Icon	Name	Description
	Intermec Ready-to-Work™ indicator	<ul style="list-style-type: none"> On when an application is communicating with the IF2 BRI server or an LLRP client has connected. Blinks when no application is communicating with the IF2. For more information, see “About the Ready-to-Work Indicator” on page 5.

IF2 LED Descriptions (continued)

Icon	Name	Description
POE	Power Over Ethernet	<ul style="list-style-type: none"> • Green if Power Over Ethernet (POE) is enabled. • Red if a fault condition is detected. For example, if the power converter for POE does not provide enough power to the IF2, the POE LED stays red indicating a fault condition. • Red if the POE converter is not capable of meeting 802.3 AT standards.. If this is the case, the IF2 continues to run if it has enough power.
	Power	On when the IF2 has power.
	Wired LAN	<ul style="list-style-type: none"> • Off when there is no Ethernet connectivity. • On when an Ethernet link is detected. • Flashes when there is activity on the Ethernet network.
	RFID status	<ul style="list-style-type: none"> • Green if RF power is being transmitted. • Red if an antenna fault is detected, or if the reader cannot output the requested RF power level. • Off if RF power is off.
	Tag ID	Flashes when an RFID tag ID is successfully read or written to.

About the Ready-to-Work Indicator

The blue Ready-to-Work indicator shows when an application is communicating with the Basic Reader Interface (BRI) server or LLRP client on the IF2. The next table explains the different states of the Ready-to-Work indicator.

Ready-to-Work Indicator Status Descriptions

Status	Description
Off	IF2 does not have power.
Blinking	IF2 is initializing and not yet ready to use, or no application is currently communicating with the IF2 BRI or LLRP server or LLRP server.
Steady	An application is communicating with the BRI server or an LLRP client has connected to the IF2.

For more information on the BRI server, see [“Configure the BRI Server” on page 45.](#)

About the Network and Power Ports

The IF2 network and power ports are located under the cable cover.

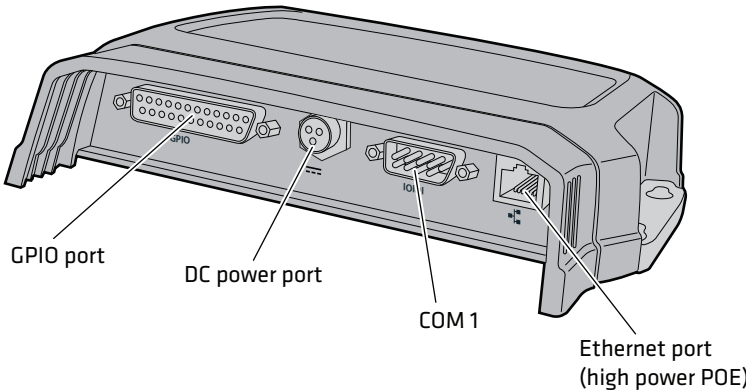

IF2 Network and Power Ports

IF2 Port Descriptions

Port	Description
GPIO	<p>General purpose input/output (GPIO) port that connects the IF2 to industrial controls such as relays or indicators.</p> <p>For more information on the IF2 GPIO interfaces, see “About the GPIO Interfaces” on page 84.</p>
DC power	<p>Connects the reader to a 12 volt DC power source.</p>
COM1	<p>Connects the IF2 to a desktop PC for configuration. Use an RS-232 null modem cable (P/N 059167).</p>
Ethernet	<p>10BaseT/100BaseTx port that connects the reader to your Ethernet network. The reader auto-negotiates with the server to set the best data rate. This port uses MDI/MDI-X auto-switching so you can connect either a standard Ethernet cable or a crossover cable.</p> <p>The Ethernet port also supports POE. To use POE you need an 802.3at compliant power converter. For more information, contact your sales representative.</p>

About the Top Panel Ports

The IF2 top panel ports consist of four antenna ports, a reset switch, and a USB service port.

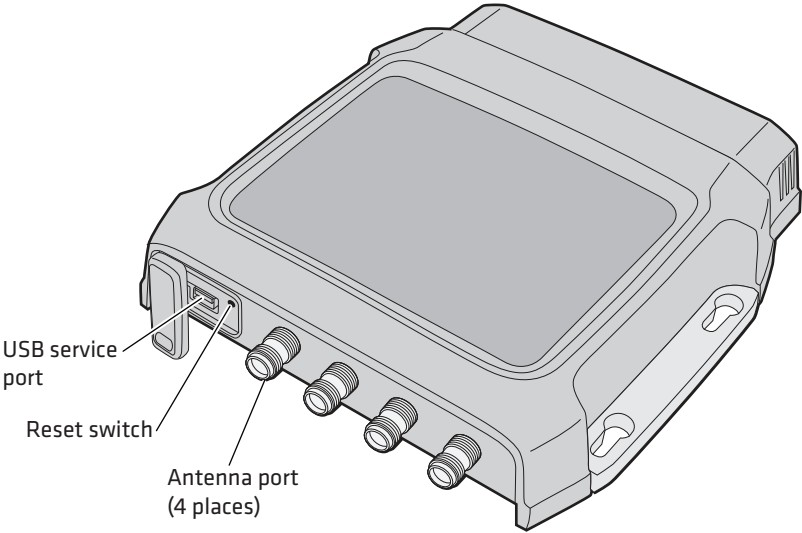

IF2 Top Panel Ports

The IF2 RFID antenna ports uses Reverse TNC connectors. Make sure you have appropriate antennas and cables for your IF2. For help, contact your sales representative.



Note: USB is not supported on the IF2 with Expanded Memory Option.



Caution

Government regulatory agencies require that this RFID reader uses only approved antennas. Therefore, this reader uses a custom antenna connector. Do not use antennas not approved for use with this reader.

How to Communicate with the IF2

By default, the IF2 is configured to be a DHCP client and accepts offers from any DHCP server. Therefore, the IF2 will work out of the box if you connect it to your network and use a DHCP server to assign it an IP address. In this case, you configure the IF2 using the web browser interface from a desktop PC. For help, see **“Use the Web Browser Interface” on page 11.**

However, if you are not using a DHCP server to assign an IP address, you use a serial communications program such as HyperTerminal to assign a static IP address. For help, see the next section, “Assigning an Initial IP Address.”

After the IF2 has been assigned an IP address, connect it to your network and then complete the configuration by using a web browser interface from a desktop PC. For help, see **“Use the Web Browser Interface” on page 11.**

Assign an Initial IP Address

Follow this procedure to assign an initial IP address to the IF2. After you assign the IP address, connect the IF2 to your network and use the web browser interface to complete the configuration.

To assign an initial IP address

- 1 Open a serial connection to the IF2. For help, see **“Open a Serial or USB Connection to the IF2”** on page 64.

```
Loading System....
Intermec IF2
Login with username/password of "config" to start initial configuration.
IF2A00000000007 login:
```

- 2 Type **config** and press **Enter**, and then type **config** again in the **Password** field and press **Enter**. The IF2 Initial Configuration screen appears.

```
-----
Intermec IF2 Initial Configuration
-----
Ethernet Configuration Options
-----
D - Enable/Disable DHCP                (Currently Disabled)
1 - Change IP Address                  (Currently 10.200.27.200)
2 - Change Subnet Mask                 (Currently 255.255.255.0)
3 - Change IP Router                   (Currently 0.0.0.0)
L - Advanced Ethernet Link Configuration
Q - Finished with Configuration

Selection: _
```

- 3 If DHCP is enabled, press **D**. DHCP is disabled and the Ethernet Configuration Options screen appears.

```
-----
Intermec IF2 Initial Configuration
-----
Ethernet Configuration Options
-----
D - Enable/Disable DHCP                (Currently Disabled)
1 - Change IP Address                  (Currently 10.200.27.200)
2 - Change Subnet Mask                 (Currently 255.255.255.0)
3 - Change IP Router                   (Currently 0.0.0.0)
L - Advanced Ethernet Link Configuration
Q - Finished with Configuration

Last Command Status: DHCP Status Changed

Selection: _
```

- 4** To set the IP address, press **1** and enter the static IP address in the entry field.
- 5** Press **Enter**. The static IP address is set. If you do not need to set the subnet mask or IP router values, you can now continue to configure the IF2 through the web browser interface. For help, see **“Use the Web Browser Interface” on page 11.**

If you need to change the values for subnet mask or the IP router, continue with the next step.
- 6** To set the subnet mask, press **2** and enter the subnet mask value in the entry field. Press **Enter** to save the changes.

To set the IP router address, press **3** and enter the IP router address in the entry field. Press **Enter** to save the changes.
- 7** (Optional) To change the Ethernet link speed, press **L** and choose a link speed from the list of options:

Ethernet Link Speed Options

To choose this speed:	Press:
Auto detect (default)	A
100 Mbps - full duplex	1
100 Mbps - half-duplex	2
10 Mbps - full duplex	3
10 Mbps - half duplex	4
Keep the current selection and close this dialog box	Q

- 8** Press **Q** to close the Initial Configuration screen.
- 9** Disconnect the null-modem cable from the IF2.

The IF2 is now ready to be connected to your network. See **“Connect the IF2 to Your Network” on page 16.**

Use the Web Browser Interface

After the IF2 is assigned an IP address, configure the IF2 using the web browser interface.

To use the web browser interface, the IF2 must be connected to your wired network. For help, see **“Connect the IF2 to Your Network” on page 16.**

When using the web browser interface, remember that your session automatically terminates if you do not use it for 15 minutes.



Note: If you access the Internet using a proxy server, add the IF2 IP address to your Exceptions list. The Exceptions list contains the addresses that you do not want to use with a proxy server.

To use the IF2 web browser interface

- 1 Determine the IP address of the IF2. If a DHCP server assigned the IP address, you need to get the IP address from that server.
- 2 Start the web browser.
- 3 In the browser address field, enter the IP address, and press **Enter**. The IF2 login screen appears.

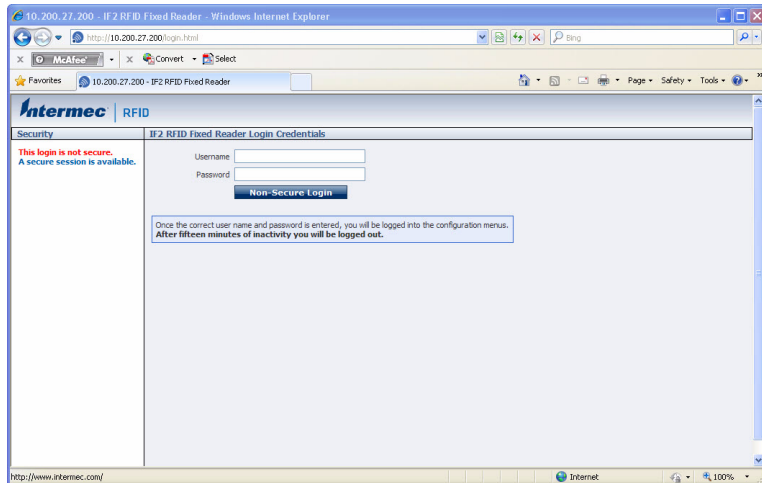

Or, for a secure session, click **A secure session is available**. The secure login screen appears.



Note: If a security alert message appears:

- Click **Yes** to continue to the secure login screen.
- Click **No** to cancel.
- Click **View certificate** to see the security certificate before continuing.

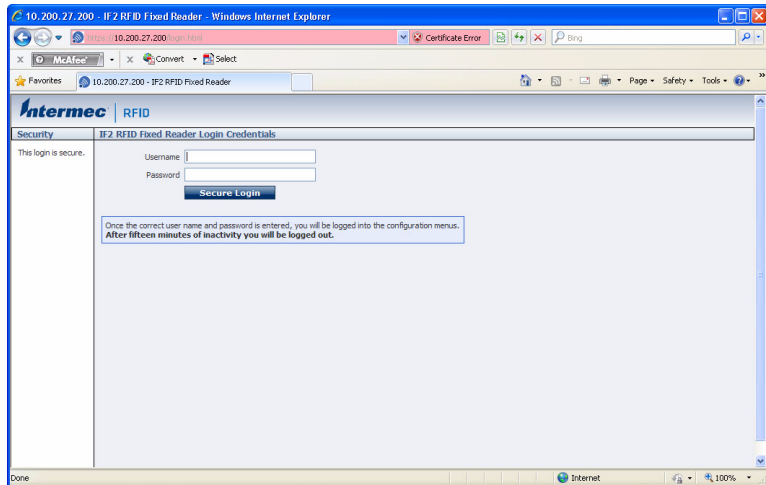

IF2 Secure Login Screen

- 4 If necessary, enter a user name and password. The default user name is `intermec` and the default password is `intermec`. You can define the user name and password. For help, see **“Set Up Logins” on page 28**.

- 5 Click **Login** (or **Secure Login** in the secure login screen). The Ethernet screen appears and your web browser session is established.

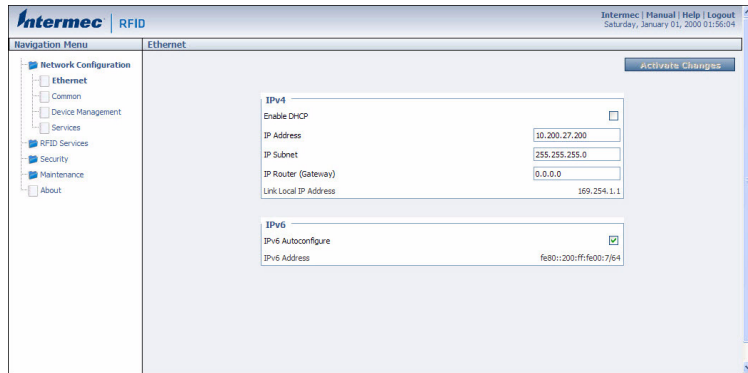

For help with configuring network settings, see [“Configure the Settings for Your Network” on page 22.](#)

For help with configuring RFID reader settings, see [“Configure BRI Settings” on page 40.](#)

For more information on other methods for managing the IF2, see [“Manage the IF2” on page 62.](#)

Save Configuration Changes

After you make configuration changes, click **Activate Changes** in the browser window to save your changes and immediately make the changes active.

Changes are discarded if you click another link in the browser window without clicking **Activate Changes** first.

Disable Help in the Web Browser Interface

By default, the web browser interface shows help text as you move the cursor over items in each screen. Follow the next procedure to disable the help text feature.

To disable help text

- 1 In the web browser interface, click **Help** in the upper right corner of the screen.



The Help screen appears.

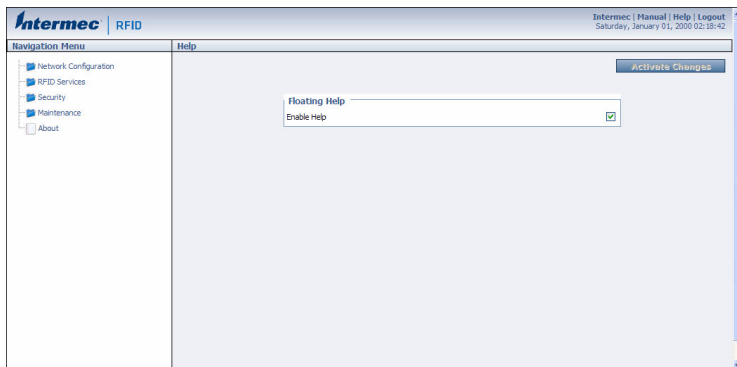

- 2 Clear the **Enable Help** check box.
- 3 Click **Activate Changes** to save your changes and immediately make them active. The Help text is disabled.

Install the IF2

This section explains how to mount the IF2 to a wall using the *IF2 Network Reader Drilling Template Instructions* that comes in the box with the IF2.



The IF2 should be professionally installed. For more information, contact your local Intermec representative.

To install the IF2

- 1 Choose a mounting location.
- 2 Use the *IF2 Network Reader Drilling Template Instructions* to drill holes in the mounting location.
- 3 Mount the IF2 using your parts and screws.

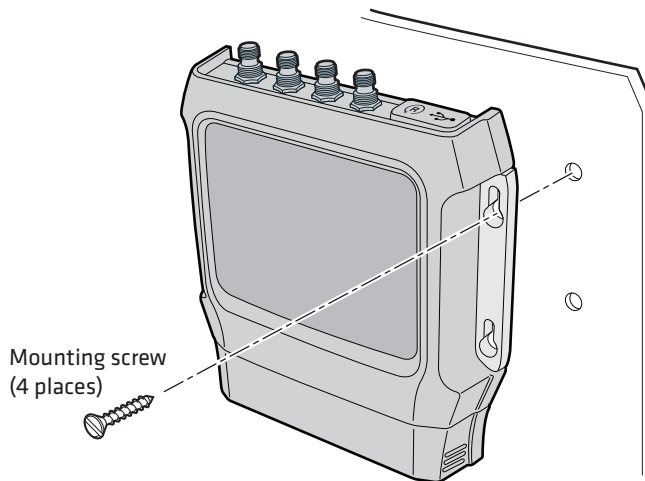

Note: The IF2 is certified to an IP53 environmental rating only when mounted as shown.

The next table includes environmental requirements for the IF2. Choose a location that meets these requirements.

IF2 Environmental Requirements

Type	Minimum	Maximum
Operating temperature	-20 °C (-4 °F)	55 °C (131 °F)
Storage temperature	-30 °C (-22 °F)	70 °C (158 °F)
Humidity (non-condensing)	5%	95%

Connect the IF2 to Your Network

After you place the IF2 in its mounting location, you can connect it to your network.

To connect the IF2 to your network

- 1** Install the IF2 in its mounting location. For help, see [“Install the IF2” on page 15.](#)
- 2** Attach one to four RFID antennas to the RFID antenna ports, starting with port 1. For help, see [“About the Top Panel Ports” on page 7.](#)
- 3** Connect an Ethernet cable to the IF2 Ethernet port.
- 4** Connect power to the IF2:
 - If you are using DC power, connect the DC power cord to a power source, and to the power port on the IF2.
 - If you are using Power Over Ethernet, connect the Ethernet cable to the Ethernet port, and use an 802.3at compliant power converter to power the IF2.

When you apply power, the IF2 boots and the green Power LED turns on.



Note: If you are using a DHCP server, make sure the server is running before you connect power to the IF2.

The IF2 is now ready to communicate with your network. Once the IF2 has been assigned an IP address (either manually or from your DHCP server), you can use the web browser interface to complete configuration. For help, see **“Use the Web Browser Interface” on page 11.**

Set the Date and Time

After you have installed the IF2, you can set the date and time via the web browser interface.

To set the date and time

- 1 Connect to the IF2 via the web browser interface. For help, see **“Use the Web Browser Interface” on page 11.**
- 2 In the web browser screen, click the date and time in the upper right corner. The Time screen appears.

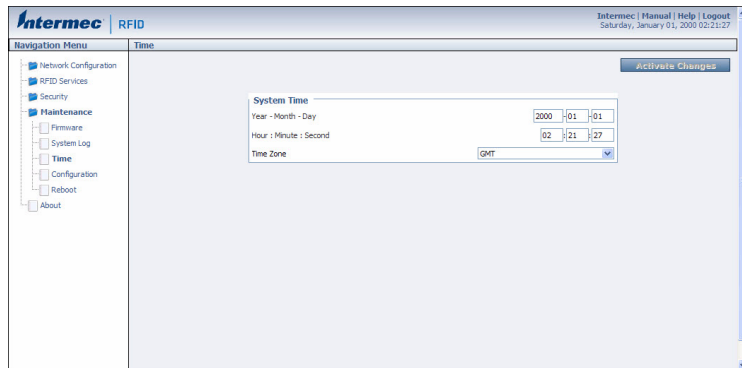

- 3 Choose your time zone from the drop-down list and then click **Activate Changes**.
- 4 Enter the current month, day, and year in the entry fields.
- 5 Enter the current hour, minute, and second in the entry fields.
- 6 Click **Activate Changes**. The new time and date are set.

How to Use the IF2 Securely

To help protect the integrity and security of your data, the IF2 supports a variety of secure access methods:

- You can use a secure web browser session (HTTPS) to access the IF2. For help, see **“Use the Web Browser Interface” on page 11.**
- You can configure and use network security methods, or disable basic configuration through the serial port. For help, see **“Configure Security” on page 26.**

2

Configure Network Settings

This chapter describes how to configure network settings for the IF2 and includes these topics:

- **Configure the Settings for Your Network**
- **Configure Security**
- **Manage Certificates**

This chapter assumes that you are familiar with your network, networking terms, and the type of security implemented by your network.

Configure the Settings for Your Network

You use the web browser interface to configure network settings. For more information on using the web browser, see **“Use the Web Browser Interface” on page 11.**

This chapter explains how to use the web browser interface to configure settings for:

- wired Ethernet connections. For help, see the next section, “Configuring Ethernet Settings.”
- parameters common to the wired connections, such as DNS addresses and time servers. For help, see **“Configure Common Network Settings” on page 25.**
- network security, such as passwords and access methods. For help, see **“Configure Security” on page 26.**
- certificates. For help, see **“Manage Certificates” on page 33.**

From a device management standpoint, there are several other methods you can use to configure network settings, including the web browsers and the Device Configuration web service. For more information on using these methods to configure the IF2, see Chapter 4, **“Manage, Troubleshoot, and Upgrade the IF2.”**

Configure Ethernet Settings

This section explains how to configure wired Ethernet settings using the web browser interface.

If you are using a DHCP server, you may not need to configure Ethernet settings. For more information, contact your network administrator.

To configure Ethernet settings

- 1 From the menu, click **Network Configuration** or **Ethernet** in the left pane. The Ethernet screen appears.

If DHCP is enabled, you see this screen:

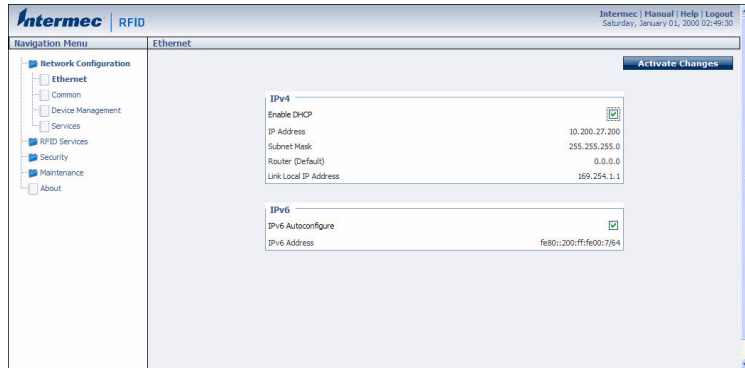

If DHCP is disabled, the current values for IP address, subnet mask, and router appear in entry fields:

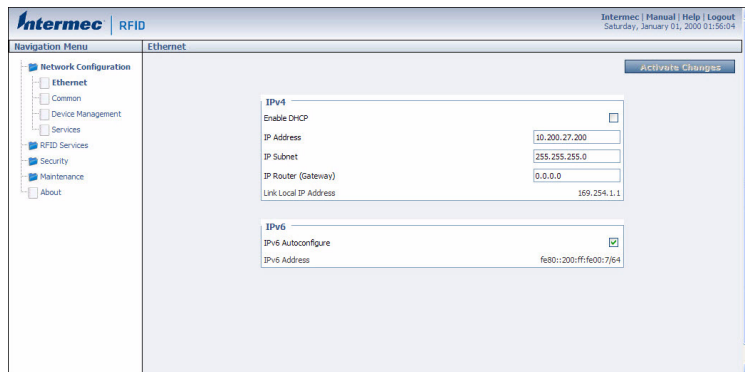

- 2 Configure the Ethernet settings. For help, see the next table.



Note: Different settings appear in this screen depending on the current DHCP mode for the IF2.

If you need to configure other network settings such as DNS addresses and suffixes or a SYSLOG destination, see **“Configure Common Network Settings” on page 25.**

- 3 Click **Activate Changes** to save your changes and immediately make them active.

Ethernet Settings Descriptions

Parameter	Description
Enable DHCP	Check this check box if you want the IF2 to get its IP address from a DHCP server. If this check box is not checked, you need to specify the IP address, subnet mask, and IP router for your network.
IP Address	IP address of the IF2. The IP address has the form $x.x.x.x$, where x is a number from 0 to 255. If DHCP is enabled, the currently assigned IP address appears in this field. If DHCP is disabled, specify the IP address in the entry field.
IP Subnet	Subnet mask for this network. The subnet mask has the form $x.x.x.x$, where x is a number from 0 to 255. If DHCP is enabled, the currently assigned subnet mask appears in this field. If DHCP is disabled, you may need to specify the subnet mask for the network.
IP Router (Gateway)	IP address of the router. The IP address has the form $x.x.x.x$, where x is a number from 0 to 255. If DHCP is enabled, the currently assigned router address appears in this field. If DHCP is disabled, you may need to specify the router address for the network.
Link Local IP Address	IP address of the IF2 is only routable on the local IP subnet. The IF2 auto-negotiates with other devices on its Ethernet segment to obtain a unique address, so no user configuration of the Link Local IP Address is necessary. The IF2 will always have a Link Local IP Address, even if another address is assigned through DHCP or statically via user-configuration.
IPv6 Autoconfigure	Enables IPv6 automatic configuration. Clear this check box to disable IPv6 auto-configuration on the IF2. Auto-configuration is enabled by default. If you disable auto-configuration, you need to specify an IPv6 address, subnet mask, and router.
IPv6 Address	128-bit IPv6 address for the IF2.
IPv6 Router	128-bit address for the IPv6 router.

Configure Common Network Settings

Common network settings are configuration items that apply to the IF2 network interface.

This section explains how to use the web browser interface to configure these common network settings:

- Hostname
- Domain Name Server (DNS) addresses and suffixes
- Simple Network Time Protocol (SNTP) server addresses 1 and 2.
For information on public NTP servers, see <http://support.ntp.org>.
- Local time zone
- SYSLOG destination

To configure common network settings

- 1 In the menu, click **Network Configuration** > **Common**. The Common screen appears.

The screenshot shows the Intermecc RFID web interface. The top navigation bar includes the Intermecc logo, 'RFID', and links for 'Manual', 'Help', and 'Logout'. The date and time are shown as 'Saturday, January 01, 2000 12:53:17'. The main content area is titled 'Common' and contains a 'Network Host Configuration' form. The form has the following fields:

Field	Value
Hostname	IP2A000000000007
DNS Server 1	
DNS Server 2	
DNS Suffix 1	
DNS Suffix 2	
SNTP Server Name 1	
SNTP Server Name 2	
Time Zone	GMT
Syslog Destination	

An 'Activate Changes' button is located in the top right corner of the configuration area.

- 2 Configure settings. For help, see the next table.
- 3 Click **Activate Changes** to save your changes and immediately make them active.

Common Network Settings Descriptions

Parameter	Description
Hostname	Name for this IF2. The default is “IF2<serial number of the IF2>”. The hostname can be either a simple hostname, or a qualified domain name (FQDN). If this IF2 obtains its IP address via DHCP, this parameter is sent to the DHCP server. If the server supports it, this field is used for dynamic DNS updates.
DNS Server 1	IP address of a domain name server that the IF2 uses to resolve DNS names.
DNS Server 2	IP address of a second domain name server that the IF2 uses to resolve DNS names.
DNS Suffix 1	Primary DNS suffix to be appended to unqualified names.
DNS Suffix 2	Secondary DNS suffix to be appended to unqualified names.
SNTP Server Name 1	DNS name or IP address of an SNTP or NTP server.
SNTP Server Name 2	DNS name or IP address of a second SNTP or NTP server.
Time Zone	Time zone for this IF2. Choose the time zone from the drop-down list. Default is GMT. For more information, see “Set the Date and Time” on page 18.
SYSLOG Destination	Domain name or IP address of the SYSLOG server.

Configure Security



Note: Before you configure security settings for this IF2, you should be familiar with the type of security implemented for your network.

The IF2 supports a variety of security features to help maintain the integrity of your secure network. You can:

- enable/disable access services.
- change the default user name and password. For help, see [“Set Up Logins” on page 28.](#)
- use a password server to maintain a list of authorized users who can configure and manage the IF2. For help, see [“Set Up Logins” on page 28.](#)

- disable serial port access to the IF2. For help, see “[Disable Access Through the Serial Port](#)” on page 32.

For general information on securely using the IF2, see “[How to Use the IF2 Securely](#)” on page 19.

Control Access Services

Access services are the different ways that users can access and configure the IF2.

You can control how developers access the IF2 by enabling or disabling these services:

- Web browser interface (secure and non-secure)
- Discovering the IF2 via Bonjour or Universal Plug and Play™ (UPnP) service advertisement (enabled by default)

To enable access services

- 1 From the menu, click **Network Configuration** > **Services**. The Services screen appears.

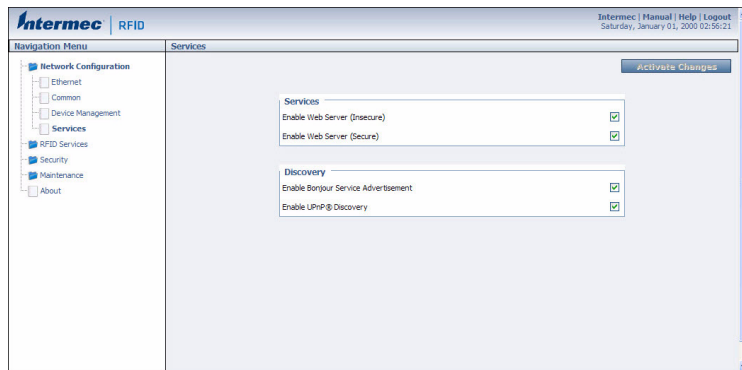

- 2 Enable or disable developer access services by checking or clearing the check boxes, or by choosing options from the drop-down list. For help, see the next table.
- 3 Click **Activate Changes** to save your changes and immediately make them active.

Access Services Descriptions

Service	Description
Enable Web Server	<p>Enables access to the IF2 via the web browser interface.</p> <p>Select Enable Web Server (Insecure) to allow users to log in using either a nonsecure (HTTP via port 80) or secure (HTTPS via port 443) web interface.</p> <p>Select Enable Web Server (Secure) to allow only the secure web interface through port 443.</p> <p>If both web server services are disabled, you need to restore the IF2 to the factory defaults. For more information, see “Restore the IF2 to the Default Configuration” on page 70.</p>
Enable Bonjour Service Advertisement	<p>Enables the IF2 to advertise services and be discovered by Bonjour zero-configuration networking. Bonjour is enabled by default.</p> <p>To prevent errors when using Bonjour, make sure the IF2 hostname does not include spaces. To set the hostname, see “Configure Common Network Settings” on page 25.</p>
Enable UPnP Discovery	<p>Enables the IF2 to be discovered by Universal Plug and Play protocols. UPnP is enabled by default.</p>

Set Up Logins

To ensure login security for configuring or maintaining the IF2, you should use a password server or at least change the default user name and password.

- A password server is typically an embedded authentication server (EAS) or other RADIUS server. To use a password server, you must have a password server on the network that contains the user name/password database. On the IF2, you need to enable RADIUS for login authorization.

When you attempt to log in to the IF2, you must enter a user name and password. This login is sent to the RADIUS server, which compares the login to its list of authorized logins. If a match is found, you can log in to the IF2 with read/write privileges.

For help, see the next section, “Configuring the IF2 to Use a Password Server.”

- If you do not want to use a password server, you should change the default login user name and password, and create a read-only password. For help, see [“Change the Default Login” on page 31](#).

Configure the IF2 to Use a Password Server

If you use a password server to manage users who log in to this IF2, you need to tell the IF2 how to communicate with the password server and then you need to configure the password server.



Note: If errors occur and you cannot log in to the IF2, restore defaults via a serial connection to reset all passwords to default values. For help, see [“Restore the IF2 to the Default Configuration” on page 70](#).

To configure the IF2 to use a password server

- 1 From the menu, click **Security** > **Passwords**. The Passwords screen appears.

The screenshot shows the Intermec RFID configuration interface. The top navigation bar includes the Intermec logo, 'RFID', and links for 'Manual', 'Help', and 'Logout'. The main content area is titled 'Passwords' and contains the following sections:

- User Credentials:** Three input fields for 'Username' (containing 'intermec'), 'Password' (masked with asterisks), and 'Read-only Password' (masked with asterisks).
- RADIUS:** A checkbox labeled 'Enable RADIUS' which is currently unchecked.
- Serial Configuration:** A checkbox labeled 'Enable Serial Configuration' which is currently checked.

A 'Navigation Menu' on the left side lists various configuration categories: Network Configuration, RFID Services, Security (expanded), Passwords (selected), Import Certificate, Certificate Details, Maintenance, and About. An 'Activate Changes' button is located in the top right corner of the main content area.

- 2 Check the **Enable RADIUS** check box. A list of RADIUS configuration items appears.

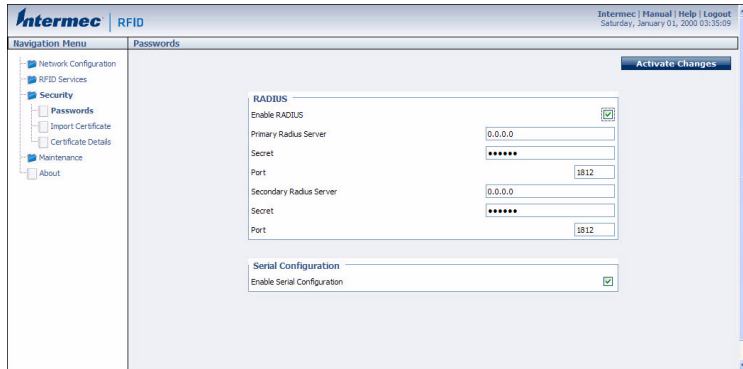

- 3 Configure the settings. For help, see the next table.
- 4 Click **Activate Changes**.
- 5 Configure the password server database. For help, see the documentation that came with your server.

RADIUS Server Information Descriptions

Type	Description
Enable RADIUS	Enables RADIUS authentication for this IF2.
Primary Radius Server	IP address or DNS name of the RADIUS server. If this field is blank, the RADIUS client does not use this entry.
Secret	Secret key for this RADIUS server.
Port	Port number of the primary RADIUS server. Default is 1812.
Secondary Radius Server	IP address or DNS name of the RADIUS server to use if there is no response from the primary RADIUS server.
Secret	Secret key for this RADIUS server.
Port	Port number of the secondary RADIUS server. Default is 1812.
Enable Serial Configuration	Enable basic network configuration using the serial or USB port.



Note: USB is not supported on the IF2 with Expanded Memory Option.

Change the Default Login

If you are not using a password server to authorize user logins, Intermec recommends that you change the default user name and password and create a read-only password.

To set up logins

- 1 From the main menu, click **Security > Passwords**. The Passwords screen appears.

- 2 Make sure the **Enable RADIUS** check box is not checked. Clear this check box if necessary and then click **Activate Changes**.
- 3 Configure the parameters. For help, see the next table.
- 4 Click **Activate Changes** to save your changes and immediately make them active.

Password Parameter Descriptions

Parameter	Description
Username	Enter the user name you need to use to log in to this IF2. The user name can be from 1 to 32 characters long. You must always specify a user name. Default is <code>intermec</code> .

Password Parameter Descriptions (continued)

Parameter	Description
Password	Enter the password you need to use to log in to this IF2. This password gives you read and write access to the IF2 configuration. The password can be from 8 to 32 characters long. You must always specify a password. Default is <code>intermec</code> .
Read-only Password	Enter the password you need to use to log in to this IF2. This password gives the user read-only access to the IF2. This user can view the configuration and execute diagnostics but cannot perform any tasks that affect IF2 operation, such as changing configuration options or upgrading firmware. Default is <code>readonly</code> . The read-only password cannot be deleted. To disallow read-only access, you need to enable RADIUS authentication. For help, see “Configure Security” on page 26 .

Disable Access Through the Serial Port

When serial port access is disabled, you also disable USB access. When you disable access, you will not be able to configure the IF2 as described in [“Assign an Initial IP Address” on page 8](#). You must use a network application (such as a web browser, SmartSystems Console, or Device Configuration Web Service application) for all configuration.



Note: USB is not supported on the IF2 with Expanded Memory Option.

To disable serial port access

- 1 From the menu, click **Security** > **Passwords**. The Passwords screen appears.

- 2 Clear the **Enable Serial Configuration** check box.
- 3 Click **Activate Changes** to save your changes and immediately make them active.

Manage Certificates

The default server certificate on the IF2 (ValidForHTTPSOnly) provides support for secure network applications such as the secure web browser interface, secure LLRP client connections, and secure web services. You can use a third-party certificate authority to issue unique client certificates and a root certificate.



Note: To install or uninstall certificates, you need to access the IF2 via a secure web browser. For help, see [“Use the Web Browser Interface” on page 11.](#)

View Certificates

You can use the web browser interface to view the certificates loaded on the IF2.

To view certificates

- From the menu, click **Security > Certificate Details**. The Certificate Details screen appears.

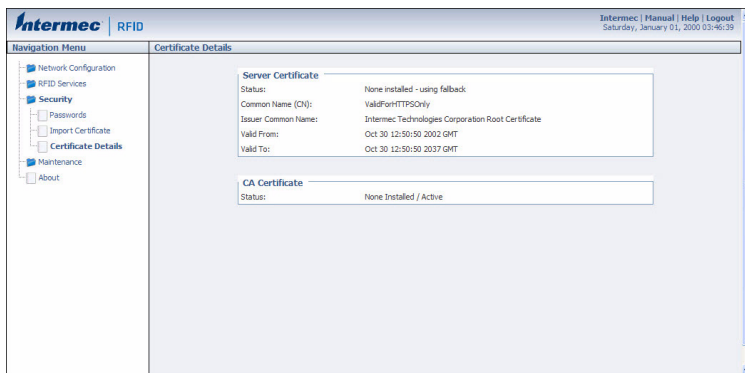

The Server Certificate table lists the server certificate that is installed, and the CA Certificate table lists the trusted CA certificate that is installed.

Install and Uninstall Certificates

Once you have determined that you need to install or uninstall a certificate, use this procedure.



Note: If you follow the procedure to uninstall all certificates, you will lose the unique server certificate and the trusted CA certificate. You will need to contact your local representative to purchase new certificates.



Note: To install or uninstall certificates, you need to access the IF2 through a secure web browser. For help, see [“Use the Web Browser Interface” on page 11.](#)

To install or uninstall certificates

- 1 From the main menu, click **Security > Import Certificate**. The Import Certificate screen appears.

- 2 Click **Browse** and follow the prompts to browse to the location of the certificate you want to install. Or, enter the path to the certificate in the **Enter or select the name of the certificate file to import** entry field.



Note: If you are not using a secure web browser, you will be prompted to log in again. Click **A secure session is available** and log in to the IF2. If a Security Alert dialog box appears, click **Yes** to proceed. Repeat Steps 1 and 2.

- 3 Click **Server Certificate** or **Trusted CA Certificate**.

Chapter 2 – Configure Network Settings

- 4** (Server Certificate only) In the **Enter the associated passphrase for this certificate** field, carefully enter the passphrase for the certificate.
- 5** Click **Import Certificate**. If a Security Alert dialog box appears, click **Yes** to proceed.

3

Develop and Use RFID Applications

This chapter explains how you can develop and test RFID applications for the IF2 and IF2 with expanded memory option and includes these topics:

- **About the IF2 Configurations**
- **RFID Applications and the IF2**
- **Create RFID Applications**
- **About RFID Services**
- **Configure BRI Settings**
- **Configure LLRP Settings**

This chapter assumes you are familiar with developing applications and with your RFID system.

About the IF2 Configurations

The IF2 comes in a standard configuration with no internal memory, or an expanded memory option.

- For the IF2, the applications you develop resides on a remote server which communicates with the reader, and all information is processed through the server.
- For the IF2 with Expanded Memory Option, the applications you develop can be hosted and run locally on the reader.



Note: This chapter applies to both the standard and expanded memory options of the IF2.

RFID Applications and the IF2

Your application communicates with the IF2 through one of two RFID services:

- the Basic Reader Interface (BRI) server, which controls the reader by issuing BRI commands. For more information on the BRI server, see **“Configure the BRI Server” on page 45.**

For more information on using BRI, see the *Basic Reader Interface Programmer’s Reference Manual*.

- the Low-Level Reader Protocol (LLRP), based on the EPCglobal standard. For more information on LLRP settings, see **“Configure LLRP Settings” on page 48.**

For more information on LLRP, see the *LLRP Programmer’s Reference Guide*.

For more information about creating an installation package or installing an application on the IF2 with Expanded Memory option, see **“Install Applications on the IF2 with Expanded Memory Option” on page 51.**

Use the RFID Resource Kit

The Intermec Developer Library RFID Resource Kit includes Java and C# tools you can use to develop applications that enable control of the reader and data management.

The resource kit is available as part of the Intermec Developer Library (IDL). To learn more about the RFID Resource Kit, go to www.intermec.com and choose **Products > Applications and Software > Development Library > Developer Resource Kits**.

Create RFID Applications

An RFID application can communicate directly with the IF2 BRI Server using the BRI protocol, or it can communicate with the IF2 using the Low-Level-Reader Protocol (LLRP).

Intermec recommends that you write and test your application on a development workstation (your desktop PC). The application can access the IF2 BRI interface via TCP on port 2189.

About RFID Services

The RFID service sets the protocol your application uses to communicate with the RFID module. The available services are:

- BRI (Basic Reader Interface) - Intermec proprietary protocol for controlling the reader. To configure BRI settings, see the next section.
- LLRP (Low-Level Reader Protocol) - EPCglobal standard for network interfaces between the RFID reader and its controlling software. To configure LLRP settings, see **“Configure LLRP Settings” on page 48**.

Configure BRI Settings

This section explains how to configure BRI settings that control reader operation and communication with your application.

- To configure BRI attribute settings that control reader operation, such as read and write tries, tag types, or antenna settings, see the next section, “Changing BRI Attribute Settings.”
- To configure BRI server settings, which manage how your application communicates with the reader, see **“Configure the BRI Server” on page 45.**

Change BRI Attribute Settings

BRI attribute settings control how the IF2 reader module reads tags. Follow the next procedure to change attribute settings.



Note: The BRI attribute settings in the web interface define the default BRI attributes when a client initially connects to the BRI. The settings do not change the attributes of any current BRI sessions.

To change BRI attribute settings

- 1 From the menu, click **RFID Services > BRI > BRI Attributes**. The BRI Attributes screen appears.

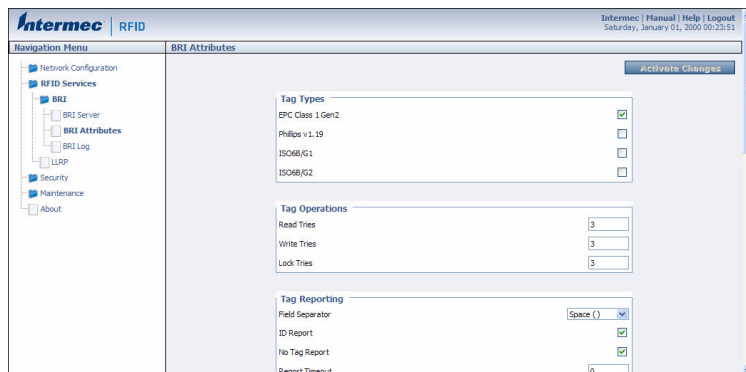

- 2 Change RFID settings as needed. For help, see the next section.
- 3 Click **Activate Changes** to save your changes and immediately make them active.

About BRI Attribute Settings

This section explains the BRI attribute settings that control how the reader operates. For more information, see the [Basic Reader Interface Programmer's Reference Manual](#).

Tag Types

Check the appropriate check boxes to enable RFID operations for these kinds of tags:

- EPC Class 1 Gen 2 (default)
- Phillips v1.19
- ISO6B/G1
- ISO6B/G2

This setting is equivalent to the TAGTYPE BRI attribute.

Read Tries

Sets the maximum number of times the read algorithm is executed before a response is returned to a Read command.

In practice, this is the number of times an identified tag is read until the Read is successful. Valid range is 1 to 254 (default is 3).

This setting is equivalent to the RDTRIES BRI attribute.

Write Tries

Sets the maximum number of times the write algorithm is executed before a response is returned to a Write command.

In practice, this is the number of times an identified tag is written to until the Write is successful. Valid range is 1 to 254 (default is 3).

This setting is equivalent to the WRTRIES BRI attribute.

Lock Tries

Sets the maximum number of times the lock algorithm is executed before a response is returned to a Lock command. Valid range is 1 to 254 (default is 3).

This setting is equivalent to the LOCKTRIES BRI attribute.

Field Separator

Sets the character to be used for separating fields in tag data. Choose from space (), comma (,), colon (:), semicolon (;), tab, caret (^), or tilde (~). Default is space.

This setting is equivalent to the FIELDSEP BRI attribute.

ID Report

Enables or disables tag ID reporting after a Read, Write, or Lock command is executed:

- For ISO tags, the tag identifier corresponds to TAGID.
- For EPC tags, the identifier corresponds to EPCID.

Check the check box to enable tag ID reporting. This setting is equivalent to the IDREPORT BRI attribute, and is enabled by default.

No Tag Report

Enables or disables a NOTAG message, which is sent when no tags are found during execution of a Read, Write, or Lock command. Check the check box to enable the message. This setting is equivalent to the NOTAGRPT BRI attribute, and is enabled by default.

Report Timeout

Sets the timeout (in ms) for delays in tag reporting when the IF2 is in continuous read mode. Range is 0 (default) to 65534.

Timeout Configuration Mode

Enables a timeout mode. Instead of specifying the number of antenna or ID tries, you specify an antenna or ID timeout value. If the IF2 does not find any tags after an antenna or ID try, the reader waits this long before starting the next antenna or ID try. If you enable timeout mode, you need to set the ID Timeout and Antenna Timeout values.

This setting is equivalent to the TIMEOUTMODE BRI attribute, and is disabled by default.

To enable Timeout Configuration mode

- 1 Check the check box. The screen refreshes. The Antenna Tries setting is replaced by Antenna Timeout, and the ID Tries setting is replaced by ID Timeout.

- 2 Specify the value (in ms) for the antenna or ID timeout in the entry fields and then click **Activate Changes**.

For more information on ID Timeout and Antenna Timeout, see those topics later in this section.

Select Tries

(Not supported by EPCglobal Class 1 Gen 2 tags) Sets the number of times a group select is attempted. A group select is the command that starts the identity process. Valid range is 1 (default) to 254.

This setting is equivalent to the SELTRIES BRI attribute.

Unselect Tries

(Not supported by EPCglobal Class 1 Gen 2 tags) Sets the number of times a group unselect is attempted. Valid range is 1 (default) to 254.

Session

(EPCglobal Class 1 Gen 2 tags only) Sets the command session parameter to the corresponding EPCglobal Class 1 Gen 2 air protocol command (default is QueryAdjust).

This setting is equivalent to the SESSION BRI attribute. For more information on this setting, see the EPCglobal Class 1 Gen 2 documentation.

Initial Q

(EPCglobal Class 1 Gen 2 tags only) Sets the initial Q parameter value used by the Query command. Valid range is 0 to 15 (default is 4). If you know there is only one tag in the field, set this attribute to 0 for best performance.

This setting is equivalent to the INITIALQ BRI attribute.

Initialization Tries

Sets the maximum number of times the reader attempts to initialize a tag. Valid range is 1 (default) to 254.

This setting is equivalent to the INITTRIES BRI attribute.

Schedule Option

Determines how antennas are switched during the inventory process. This attribute controls the behavior of the inventory scheduling parameters.

This setting is equivalent to the SCHEDULOPT BRI attribute.

ID Tries

Sets the maximum number of times the reader executes the identify algorithm before a response is returned to a Read or Write command.

In practice, this is the number of times a tag ID attempt is made for each antenna being used. Valid range is 1 to 254 (default is 3).

This setting is equivalent to the IDTRIES BRI attribute.

Antenna Tries

Sets the maximum number of ID Tries that the reader executes per antenna. Valid range is 1 to 254 (default is 3).

This setting is equivalent to the ANTTRIES BRI attribute.

EPCC1G2 Advance Medium Access Mode

Selects low-level protocol (such as tari and back-link frequency) settings. If you are using CAEN tags, you must enable this mode before the tags can be read.

This setting is equivalent to the EPCC1G2PARAMETERS or EPCC1G2PARMS BRI attribute.

Dense Reader Mode

Allows the reader to hop between channels within a certain frequency spectrum to prevent other readers in the area from interfering with one another.

This setting is equivalent to the DENSEREADERMODE or DRM BRI attribute.

Antenna Field Strength 1 to 4

Sets the RF power level (in dBm) for each of the 4 antenna ports. Valid range is 15 to 30. Default is 30. Note that the maximum power level is dependent on the region that the IF2 is operating in.

Use this setting to attenuate the antenna field strength. In some situations, full output power can cause unnecessary interference. For example, if the tag is close to the antenna, full output power might overload the tag and cause unreliable behavior.

This setting is equivalent to the FIELDSTRENGTH BRI attribute.

Antenna Sequence: First through Eighth

Sets the RFID antenna to be used for each of up to eight tag inventory operations. Choose any one of the 16 available antennas from the drop-down list. If more than one antenna is enabled, the antennas fire in this sequence.

This setting is equivalent to the ANTS BRI attribute.

Configure the BRI Server

The IF2 BRI server handles communication between your application and the RFID module. When your application is communicating with the BRI server, the blue Intermec Ready-To-Work Indicator on the IF2 front panel turns on and stays on. For more information, see [“About the Ready-to-Work Indicator” on page 5](#).

To configure BRI server settings

- 1 From the menu, click **RFID Services** > **BRI** > **BRI Server**. The BRI Server screen appears.

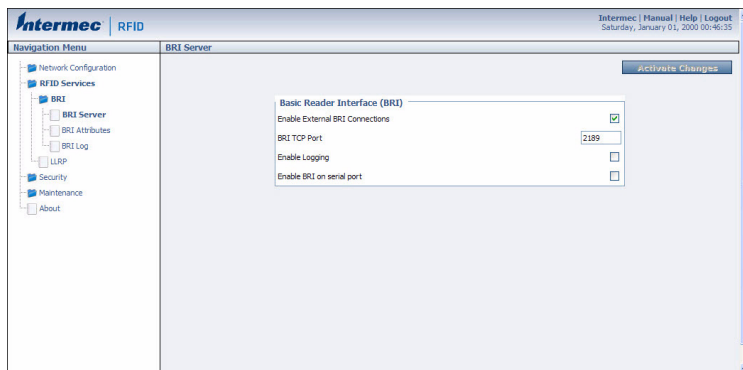

- 2** Change BRI server settings as needed. For help, see the next table.
- 3** Click **Activate Changes** to save your changes and immediately make them active.

BRI Server Parameter Descriptions

Parameter	Description
Enable External BRI Connections	Enables/disables external TCP connections to the BRI server. If this check box is not checked, BRI applications will not be able to connect to the IF2.
BRI TCP Port	Specifies the TCP port used for incoming connections to the BRI server. This port must be unique for all TCP services running on the IF2. Valid range is 2189 to 65535. Default is 2189.
Enable Logging	Enables/disables logging of BRI server events. For more information on logging, see the next section.
Enable BRI on serial port	Enables/disables sending BRI commands through the serial port.

View the BRI Server Log

If you enable logging, you can see a list of BRI server events. You can save the logfile as a .txt file.

To enable BRI server logging and view the logfile

- 1** Enable BRI logging as described in the previous section, **“Configure the BRI Server” on page 45**.

- 2 In the left navigation list, click **RFID Services > BRI > BRI Log**. The BRI Log screen appears with a list of BRI events. For more information on server events, see the next table, “BRI Event Descriptions.”

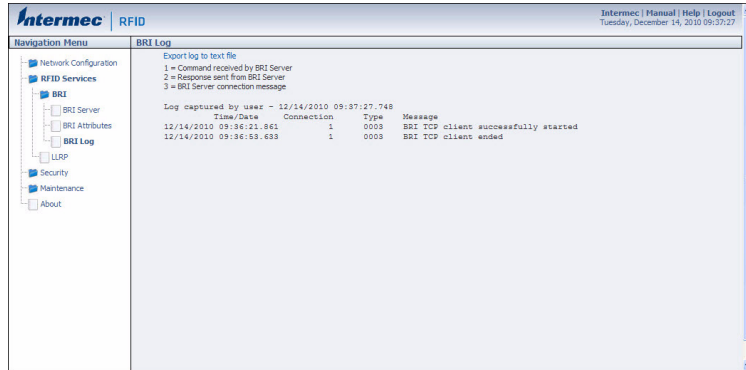

- 3 To save the log file, click **Export log to text file** and then choose **File > Save As**. Follow the prompts to save the log file to your desktop PC.

BRI Event Descriptions

Event Name	Description
Time/Date	Time and date of the event.
Connection	Session ID of the client communicating with the BRI server.
Type	Message type of the event, generally indicating which system sent the message: 1 = Command received by BRI server 2 = Response sent by BRI server 3 = BRI server connection message
Message	Text of the message, including responses.

Configure LLRP Settings

The IF2 supports version 1.0.1 of the EPCglobal Low-Level Reader Protocol (LLRP), which establishes a specific interface method between a reader and its corresponding client. Follow the next procedure to configure LLRP settings.

For information on LLRP, including standards, see <http://www.epcglobalinc.org/standards/llrp>. An open source LLRP Toolkit can be downloaded at <http://sourceforge.net/projects/llrp-toolkit>.

To configure LLRP settings

- 1 From the menu, click **RFID Services** > **LLRP**. The LLRP screen appears.

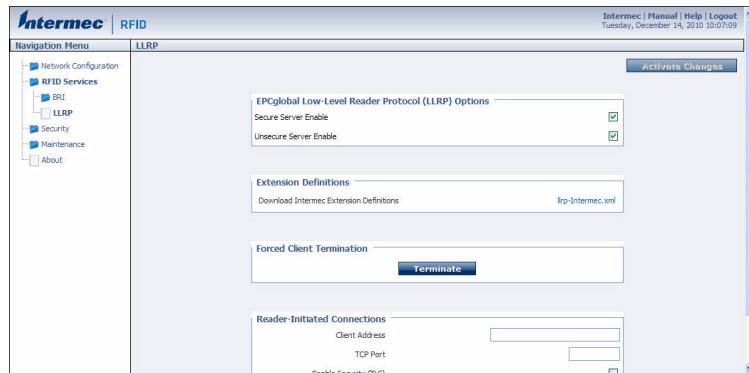

- 2 Configure LLRP settings as needed. For help, see the next table.
 - To disconnect an existing LLRP connection, click **Terminate**.
 - To connect to a remote LLRP client, enter information in the Reader-Initiated Connections section, and then click **Initiate**.
- 3 Click **Activate Changes** to save your changes and immediately make them active.

LLRP Settings Descriptions

Setting	Description
Secure Server Enable	Check this check box to allow connections to the secure LLRP server on port 5085.
Unsecure Server Enable	Check this check box to allow connections to the unsecure LLRP server on port 5084.
Download Intermec Extension Definitions	Click the link to download the Intermec extension definitions xml file.
Reader-Initiated Connections	For reader-initiated TCP/IP connections to a remote LLRP client, enter this information: <ul style="list-style-type: none">• Client Address - IP address of the remote LLRP client.• TCP Port - Port number for the TCP/IP socket connection.• Enable Security (TLS) - Check this check box to enable Transport Layer Security for this TCP/IP connection.

4

Install Applications on the IF2 with Expanded Memory Option

This chapter explains how you can develop and install applications on the IF2 with Expanded Memory option.

- **Create a Configuration File**
- **Auto-Start Applications at Boot Time**
- **About .NET Support**
- **About Java Support**
- **Install RFID Applications**
- **About the Edgeware Applications**
- **About the Developer Tools**

This chapter assumes you are familiar with developing applications and with your RFID system.

Create a Configuration File

When you package your application for installation on the IF2, you need to include a configuration file in the root directory of the archive. The file must be named “userapp.conf” and must include this syntax:

```
AUTOSTART=true|false  
RUNAFTERINSTALL=true|false  
CMDLINE=<command line to start the application>
```

where:

AUTOSTART specifies whether or not the application should automatically be executed when the IF2 boots. When AUTOSTART=true, the Auto-Start check box for this application on the Application Control screen will be checked.



Note: After you install the application on the IF2, you can enable or disable the auto-start feature from the web browser interface. For help, see [“Manage Applications” on page 56](#).

RUNAFTERINSTALL specifies whether or not the application should be started immediately after installation.

CMDLINE specifies the application name and optional parameters it accepts. Specify command line parameters as if the application is being executed from inside the directory containing the application.



Note: Do not use the \$JAVA_HOME environment variable in the command line.

This example runs a C# application named “testapp.exe” using the Mono runtime:

```
CMDLINE= ./testapp.exe
```

For Java applications, CMDLINE should specify the Java interpreter location, the classpath, and the class containing the application’s entry point. This example runs the class “HelloWorld”:

```
CMDLINE=/usr/java/bin/java -cp . HelloWorld
```



Note: The IF2 executes applications from their installation directories, so the userapp.conf file does not need to include path information.

Auto-Start Applications at Boot Time

There are two ways to configure your application to auto-start when the IF2 boots:

- Specify `AUTOSTART=true` in the configuration file that you deliver with the application. For more information, see [“Create a Configuration File” on page 52](#).
- After you install the application on the IF2, you can use the web browser interface to configure the application to auto-start at boot time. For help, see [“Use the Web Browser Interface” on page 11](#).

About .NET Support

The IF2 supports applications based on .NET Framework 1.0, 1.1, and 2.0. The IF2 uses Mono open source software to provide support for .NET applications deployed on the IF2 Linux operating system.



Note: The IF2 does not support ASP.NET.

About Java Support

The IF2 comes with a JDBC driver you can use to create applications that write data directly from the IF2 to a remote database. For more information, see [“Java Support for Microsoft SQL Server and Sybase” on page 55](#).

For more sophisticated Java development, the IF2 supports the open standard OSGi service-oriented architecture. This allows system administrators to install, uninstall, enable, and disable system services (also known as bundles) without having to reboot the IF2 each time. To use OSGi effectively, you need an OSGi server. For more information, go to www.osgi.org.

Execute Java Applications

To execute a Java application on the IF2, use this command:

```
$JAVA_HOME/bin/java myJavaClass
```

To execute .jar files, use this command:

```
$JAVA_HOME/bin/java -jar myApplication.jar
```



Note: Your .jar files must have manifest files included within them, or the command will not work:

- The manifest needs to include an attribute called “Main-Class” to specify the application’s entry point (for example, Main-Class: MyJavaClass).
- If the executable .jar needs to reference other .jar files, specify the files in the manifest file using the “Class-Path” attribute.

To enable the Java just-in-time (JIT) compiler for maximum performance, use this command:

```
$JAVA_HOME/bin/java -jit java -jar MyJar.jar
```

where:

`$JAVA_HOME` is an environment variable that indicates the Java runtime installation path (`/usr/java`). Always use this variable for simplicity and to insure that the correct runtime files are used.

`java` is the name of the Java runtime executable installed in the IF2.

If your application references third party Java libraries (such as components from the Intermec RFID Resource Kit), you must use the “-cp” option to specify the class path for the JVM to find the Java classes. Be sure to include the current path so classes in the current directory can be found, as shown in this example:

```
$JAVA_HOME/bin/java -cp ../BasicRFID.jar MyClass
```

Java Support for Microsoft SQL Server and Sybase

The IF2 jTDS driver (version 1.2) provides JDBC capabilities to Java applications running on the IF2. You need to include the location of JDBC drivers in the class path. Use the environment variable \$JDBC_HOME as shown in this example:

```
$JAVA_HOME/bin/java -cp $JDBC_HOME/jtds-j2me-1.0.2.jar:. MyClass
```

The IF2 JDBC driver supports JDBC 1.0 and:

- Microsoft SQL Server versions 6.5, 7, 2000, and 2005.
- Sybase versions 10, 11,12, and 15.

For more information on the jTDS driver, go to:

<http://jtds.sourceforge.net>.

Install RFID Applications

The IF2 provides up to 96 MB of storage for your applications. You use the web browser interface to install applications on the IF2 as described in the next procedure.



Note: Before you install your application on the IF2, you must place the application into a .zip, .tar, .tar/bz2, or .tar/gz file.

To install applications on the IF2

- 1** From the menu, click **Edgeware Applications > Install User Application**. The Install User Application screen appears.
- 2** Click **Browse** and follow the prompts to navigate to the location of the application file.
- 3** Click **Upload**. The application is uploaded to the IF2 and placed in the /home/developer/edgeware/userapp0 directory. After the application is uploaded to the reader, the application name appears in the **Edgeware Applications** list.

Manage Applications



To maximize IF2 resources, you can start, stop, or uninstall IF2 edgeware applications or your installed applications from the web browser interface. You can also configure applications to auto-start at boot time. For more information, see the next section.

To manage applications

- 1 From the menu, click **Edgeware Applications > Application Control**. The Application Control screen appears.

The Edgeware Applications section lists all installed edgeware. The User Applications section lists all applications you have installed through the web browser interface.

In this screen, you can:

- specify which applications automatically start when the IF2 boots.
 - turn applications on and off in real time.
 - uninstall applications (except for Developer Tools).
- 2 Choose an option:
 - Check the Auto-Start check box if you want an application to automatically launch when the IF2 boots.
 - Click  to stop a running application.
 - Click  to start an application.
 - Click  to uninstall an application.
 - 3 Click **Activate Changes** to save your changes and immediately make them active.



Note: If you change the date or time on the IF2, stop and restart any running applications (or reboot the IF2) for the date and time changes to be made effective.

About the Edgeware Applications

Edgeware applications are supplied by Intermec and its partner developers, and provide immediate functionality for your RFID system. The IF2 includes these edgeware applications:

- The Developer Tools. Use the Developer Tools to test your RFID systems and settings. For more information, see [“About the Developer Tools” on page 58](#).
- The SAP device controller. Enable this edgeware so the controller communicates with the SAP backend module on your server. For more information on SAP implementation on the IF2, see the [SAP Device Controller User’s Guide](#) (P/N 934-025-xxx).

You can uninstall any edgeware application other than the Developer Tools, Java Runtime Environment, and Mono Runtime Environment. For help, see the previous section, “Managing Applications.”

There are many upgrades for existing edgeware applications, as well as additional edgeware applications you can install. For help with locating IF2 upgrades, see [“Access Web Pages” on page 78](#). To install or upgrade edgeware applications, see the next section.

Upgrade or Install Edgeware Applications

You use the web browser interface to install or upgrade IF2 edgeware applications, such as the SAP device controller.



Note: Use only .bin files provided by Intermec. To install your own applications in .zip, .tar, .tar/bz2, or .tar/gz formats, see [“Install RFID Applications” on page 55](#).

To install or upgrade edgeware

- 1** From the menu, click **Edgeware Applications > Install Edgeware**. The Install Edgeware screen appears.
- 2** Click **Browse** and follow the prompts to navigate to the location of the .bin file.
- 3** Click **Upload**. The application file is installed on the IF2. When the installation is complete, the reader reboots.

About the Developer Tools

Use the Developer Tools for basic testing of your RFID system. The Developer Tools support these features:

- General purpose input/output (GPIO) testing. For help, see the next section.
- Sending BRI commands or BRI script files to the IF2 from an interactive browser interface. For help, see [“Send BRI Commands and Running Scripts” on page 59.](#)
- Editing and testing JavaScript files. For help, see [“Use the Workbench” on page 59.](#)



Note: To use the Developer Tools, you need to enable them. For help, see [“About the Edgware Applications” on page 57.](#)

Test the GPIO Interfaces

If you have external GPIO controls such as motion sensors or indicator lamps connected to the IF2, you can use the Diagnostics tool to test the interfaces and verify that the controls behave as expected. Leave the controls connected to the IF2 GPIO port when using the Diagnostics tool.

To test the GPIO interfaces

- 1 From the menu, click **Edgware Applications > Developer Tools > GPIO**. The GPIO screen appears.
- 2 Check the check box for each of the GPIO interfaces you want to test. When you check the check box, that GPIO output will be turned on, and its associated GPIO input is turned on.
- 3 Click **Read and Write GPIO**. The GPIO interface state is changed.

Send BRI Commands and Running Scripts

You can send BRI commands to the IF2 or load and run a BRI script through the web browser interface.

To send BRI commands

- 1 From the menu, click **Edgeware Applications > Developer Tools > BRI Commands**. The BRI Commands screen appears.
- 2 Enter the BRI command in the **Command** entry field.
- 3 Click **Run**. The command is executed and return values appear onscreen. For example, if you sent the ATTRIB command, the reader attributes appear in the list.

To load and run a BRI script

- 1 From the menu, click **Edgeware Applications > Developer Tools > BRI Commands**. The BRI Commands screen appears.
- 2 Click **Browse** and browse to the location of the BRI script.
- 3 Double-click the name of the file. The script filename appears in the **Script name** field.
- 4 Click **Load**. The script is loaded and run, and return values appear onscreen.

Use the Workbench

You can create and edit a JavaScript file, load the file on the IF2, and run the file from the Workbench.



Note: These instructions assume you understand how to create and edit JavaScript files.

To create and run a JavaScript file

- 1 From the menu, click **Edgeware Applications > Developer Tools > Workbench**. The Workbench screen appears.
- 2 Click in the JavaScript Code box to enter code. You can also paste text copied from Notepad or another application. Copy the text from the other application and choose **Edit > Paste** in the browser menu.

Chapter 4 – Install Applications on the IF2 with Expanded Memory Option

- 3** To save your JavaScript code to the IF2 work buffer, click **Save As** and enter a new file name in the entry field. Click **OK**.

If you previously saved your JavaScript, click on the drop-down menu and select the file name to reload it in the JavaScript Code box.

- 4** Click **Run**. The IF2 runs the JavaScript. Responses from the reader appear in the output pane. For example, if your script instructed the reader to read tags, the tag IDs appear in the Output Pane.

5

Manage, Troubleshoot, and Upgrade the IF2

This chapter includes information on managing the IF2 and includes these topics:

- **Manage the IF2**
- **Use the Device Configuration Web Service**
- **Open a Serial or USB Connection to the IF2**
- **Maintain the IF2**
- **Troubleshoot the IF2**
- **Call Intermec Product Support**
- **Access Web Pages**
- **Upgrade Firmware**

Manage the IF2

There are two methods you can use to manage the IF2. You can use:

- a web browser. For help, see [“Use the Web Browser Interface” on page 11](#). This manual assumes you are using this method for all procedures.
- the Device Configuration web service. For help, see the next section.

Use the Device Configuration Web Service

The Device Configuration web service provides a way to programmatically configure the IF2 over your network. This SOAP-based service provides a configuration API that allows you to specify a variety of network, RFID, and system settings via XML-encoded messages.

Follow the next procedure to enable the web service or to download the Device Configuration web service description language (WSDL) document.

For more information on the Device Configuration web service, see the [Device Configuration Web Service Command Reference Manual](#).

To enable the web service and download the WSDL document

- 1 From the menu, click **Network Configuration > Device Management**. The Device Management screen appears.

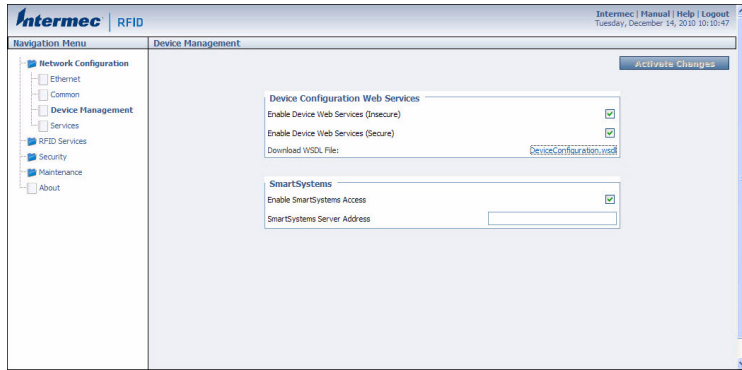

By default, Device Configuration web services are enabled for either secure or insecure connections.

- 2 To disable web services over a secure connection, clear the **Enable Device Web Services (Secure)** check box, and then click **Activate Changes**.

To disable web services over an insecure connection, uncheck the **Enable Device Web Services (Insecure)** check box, and then click **Activate Changes**.

To download the device configuration WSDL document, click **DeviceConfiguration.wsdl**. The document opens in the browser window.



```
<?xml version="1.0" encoding="UTF-8" ?>
- <definitions name="DeviceConfiguration" targetNamespace="http://10.200.27.200:64907/DeviceConfiguration.wsdl"
  xmlns:tns="http://10.200.27.200:64907/DeviceConfiguration.wsdl" xmlns:SOAP-ENV="http://schemas.xmlsoap.org/soap/envelope/"
  xmlns:SOAP-ENC="http://schemas.xmlsoap.org/soap/encoding/" xmlns:xsi="http://www.w3.org/2001/XMLSchema-instance"
  xmlns:xsd="http://www.w3.org/2001/XMLSchema" xmlns:ids="http://www.w3.org/2001/XMLSchema" xmlns:idsws="idws"
  xmlns:SOAP="http://schemas.xmlsoap.org/wsdl/soap/" xmlns:MIME="http://schemas.xmlsoap.org/wsdl/mime/"
  xmlns:DIME="http://schemas.xmlsoap.org/ws/2002/04/dime/wsdl/" xmlns:WSDL="http://schemas.xmlsoap.org/wsdl/"
  xmlns="http://schemas.xmlsoap.org/wsdl/">
- <types>
- <schema targetNamespace="idws" xmlns:SOAP-ENV="http://schemas.xmlsoap.org/soap/envelope/" xmlns:SOAP-ENC="http://schemas.xmlsoap.org/soap/encoding/"
  xmlns:xsi="http://www.w3.org/2001/XMLSchema-instance" xmlns:xsd="http://www.w3.org/2001/XMLSchema" elementFormDefault="qualified"
  attributeFormDefault="unqualified">
- <import namespace="http://schemas.xmlsoap.org/soap/envelope/" />
- <simpleType name="ReadyToWorkState">
- <restriction base="xsd:string">
- <enumeration value="RTW-Error" />
- <!-- enum const = 0 -->
- <enumeration value="RTW-Warning" />
- <!-- enum const = 1 -->
- <enumeration value="RTW-Ready" />
- <!-- enum const = 2 -->
- </restrictions>
- </simpleType>
- <simpleType name="RadioMode">
- <restriction base="xsd:string">
- <enumeration value="RadioMode-Unknown" />
- <!-- enum const = 0 -->
- <enumeration value="RadioMode-Auto" />
- <!-- enum const = 1 -->
- </restrictions>
- </simpleType>
```

Open a Serial or USB Connection to the IF2

You can connect the IF2 to your desktop PC via the serial or USB port to perform these tasks:

- Assign the IF2 an initial IP address.
- Restore default settings.
- Establish a BRI session.

Open a Serial Connection to the IF2

If you are opening a serial connection to the IF2, you need:

- a null-modem cable (P/N 059167).
- a communications program such as HyperTerminal.



Note: If you have Microsoft ActiveSync running on your desktop PC, disable ActiveSync to make the serial port available.

To connect to the IF2 via the serial port

- 1 Connect the null-modem cable from the serial port on the IF2 to a serial port on your PC.
- 2 Start the communications program and configure the serial port communications parameters to:
 - Bits per second: 115200
 - Data bits: 8
 - Parity: None
 - Stop bit: 1
 - Flow control: None
- 3 Connect the IF2 to power. The IF2 boots as soon as you apply power. In about a minute, the message “Loading System” appears as the IF2 initializes, and in another minute or two the login message appears.

```
Loading System...
Intermec IF2
Login with username/password of "config" to start initial configuration.
IF2A000000000007 login:
```

The serial connection is established. From here you can do these tasks:

- You can assign an initial IP address to the IF2 for configuration. For help, see [“Assign an Initial IP Address” on page 8.](#)

- You can restore default settings. For help, see **“To restore defaults with a serial connection” on page 72.**
- You can open a BRI session.

Open a USB Connection to the IF2

If you are connecting the IF2 using a USB connection, you need:

- a USB cable.
- to create a folder with a gserial.inf and a usbser.sys file.



Note: USB is not supported on the IF2 with Expanded Memory Option.

To connect to the IF2 using the USB port

- 1** Create a folder to place the gserial.inf and usb.sys file in.
- 2** Click **Start > Programs > Accessories > Notepad.**
- 3** In Notepad, copy and paste the following text:

```
[Version]
Signature="$Windows NT$"
Class=Ports
ClassGuid={4D36E978-E325-11CE-BFC1-08002BE10318}
Provider=%LINUX%
DriverVer=08/17/2004,0.0.2.0
; Copyright (C) 2004 Al Borchers (alborchers@steinerpoint.com)

[Manufacturer]
%LINUX%=GSerialDeviceList

[GSerialDeviceList]
%SERIAL%=GSerialInstall, USB\VID_0525&PID_A4A7

[DestinationDirs]
DefaultDestDir=10,System32\Drivers

[GSerialInstall]
CopyFiles=GSerialCopyFiles
AddReg=GSerialAddReg

[GSerialCopyFiles]
usbser.sys
```



```
[GSerialAddReg]
HKR,,DevLoader,,*ntkern
HKR,,NTMPDriver,,usbser.sys
HKR,,EnumPropPages32,,"MsPorts.dll,SerialPortPropPageProvider"

[GSerialInstall.Services]
AddService = usbser,0x0002,GSerialService

[GSerialService]
DisplayName = %GSERIAL_DISPLAY_NAME%
ServiceType = 1 ; SERVICE_KERNEL_DRIVER
StartType = 3 ; SERVICE_DEMAND_START
ErrorControl = 1 ; SERVICE_ERROR_NORMAL
ServiceBinary = %10%\System32\Drivers\usbser.sys
LoadOrderGroup = Base

[Strings]
LINUX = "Linux"
GSERIAL = "Gadget Serial"
GSERIAL_DISPLAY_NAME = "USB Gadget Serial Driver"
```

- 4** Click **File** > **Save As**.
- 5** Browse to the folder that you created in Step 1.
- 6** In the **File name:** text box, type **gserial.inf**, and click **Save**.
- 7** Browse to the c:\Windows\Driver Cache\i386 directory and locate the driver.cab file.
- 8** Open the driver.cab file with a .cab extraction tool and find the usb.sys file.
- 9** Copy the usb.sys file to the folder you created in Step 1.
- 10** Connect the IF2 to your PC using a USB cable. The Found New Hardware Wizard appears.
- 11** Select **Install from a list or specific location (Advanced)**, and click **Next**.
- 12** Select **Include this location in the search**, and enter browse to the folder you created in Step 1.
- 13** Click **Continue Anyway** when the Windows Logo Testing screen appears. The IF2 is connected by a USB connection. From here you can do these tasks:

- You can assign an initial IP address to the IF2 for configuration. For help, see **“Assign an Initial IP Address” on page 8.**
- You can restore default settings. For help, see **“To restore defaults with a serial connection” on page 72.**
- You can open a BRI session.

Maintain the IF2

The Maintenance menu lets you view IF2 parameters and statistics, including a list of logged events. You may need this information if you need to call Intermec Product Support.

View the System Log

The System Log screen shows events that have been logged by the IF2.

To view the System Log screen

- 1 From the menu, click **Maintenance > System Log**. The System Log screen appears. This screen is read-only.

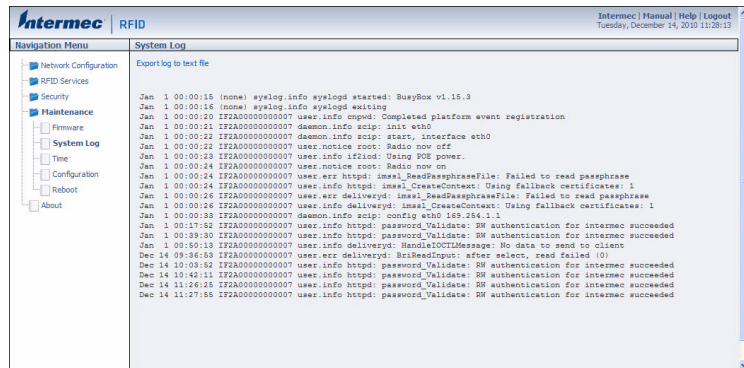

- 2 To save the list, click **Export log to text file**. The log is saved as Syslog.log and appears in the browser window.
- 3 Choose **File > Save As** and follow the prompts to save the log file to your desktop PC.

View the About Screen

The About screen lists installed software versions, serial numbers, and other IF2-specific information.

To view the About screen

- From the menu, click **About**. The About screen appears. This screen is read-only.

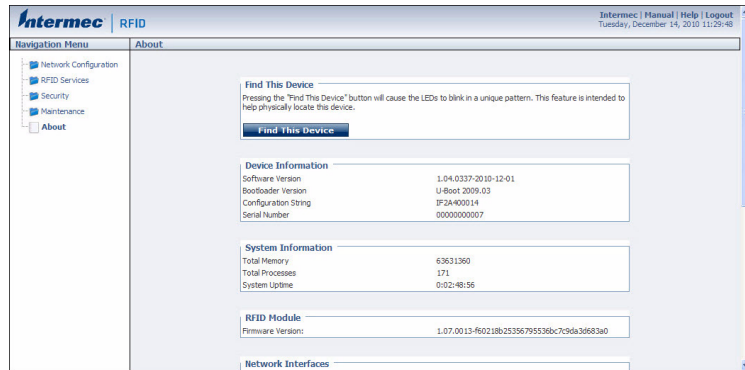

The About screen includes this information:

- Device information: IF2 firmware version, hardware configuration string, and serial number.
- System information: Available memory, number of running processes, and amount of time the IF2 has been running.
- RFID Module firmware: Firmware version installed.
- Network interface information.
- Installed subsystems: versions of all currently loaded IF2 subsystems, including Linux.

Use the LEDs to Locate the IF2

You can use the LEDs to help locate a specific IF2 in your location.

To locate an IF2

- In the About This IF2 RFID Reader screen, click **Find This Device**. All of the LEDs except the Power and Wired LAN LEDs flash. Click **Finished Finding This Device** to turn off the LEDs.

Restore the IF2 to the Default Configuration



Note: Restoring default settings as described in this section does not affect security certificates you have installed.

There are four ways to restore the default configuration on the IF2:

- You can restore default settings from the web browser interface. For help, see the next section.
- You can restore default settings by pressing the reset switch located on the top of the IF2.
- You can restore default settings through a serial connection. For help, see **“To restore defaults with a serial connection” on page 72.**
- You can restore default settings using the Device Configuration Web Services. For help, see the *Device Configuration Web Services Command Reference Manual*.

Restore Default Settings with the Web Browser

If you are having problems with the IF2, you can use the web browser interface to restore the default settings to the IF2.

To restore defaults with the web browser

- 1 From the menu, click **Maintenance > Configuration**. The Configuration screen appears and displays all configuration changes from the factory default settings.

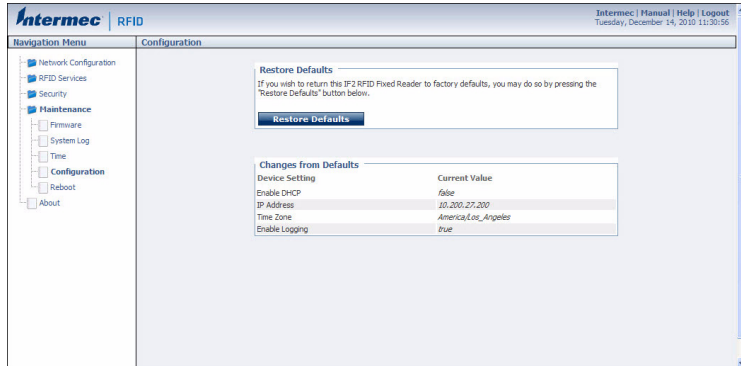

- 2 Click **Restore Defaults**. A confirmation message appears.
 - 3 Click **OK**. The IF2 reboots and restores the default configuration.
- Or, click **Cancel** to close the confirmation message without restoring defaults.

Restore Default Settings with the Reset Switch

If you are having problems with the IF2, you can press the reset switch to restore the default settings to the IF2.

To restore defaults with the reset switch

- 1 Make sure the IF2 is powered on.
- 2 Using a paper clip, push and hold the reset switch for three seconds. The LEDs on the IF2 flashes.

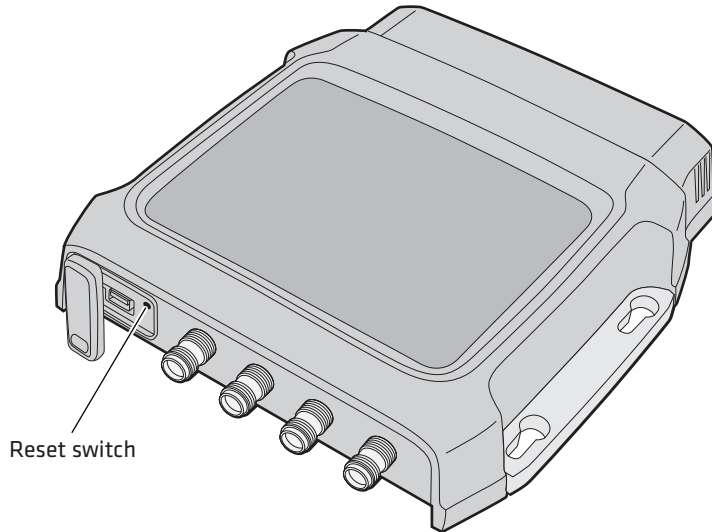

- 3 Release the reset switch. The IF2 reboots and restores the default configuration.

Restoring Default Settings with a Serial Connection

If you are having problems with the IF2, you can use a serial connection to restore the default settings to the IF2.

To restore defaults with a serial connection

- 1 Open a serial connection to the IF2. For help, see [“Open a Serial or USB Connection to the IF2”](#) on page 64.
- 2 In the login field, type `restore_defaults` and then press **Enter**.
- 3 In the Password field, press **Enter**. The IF2 reboots and the default settings are restored.

Reboot the IF2

You can reboot the IF2 from the web browser interface as described in the next procedure. For example, you may need to reboot the IF2 to enable changes in an application.

To reboot the IF2

- 1 From the menu, click **Maintenance** > **Reboot**. The Reboot screen appears.

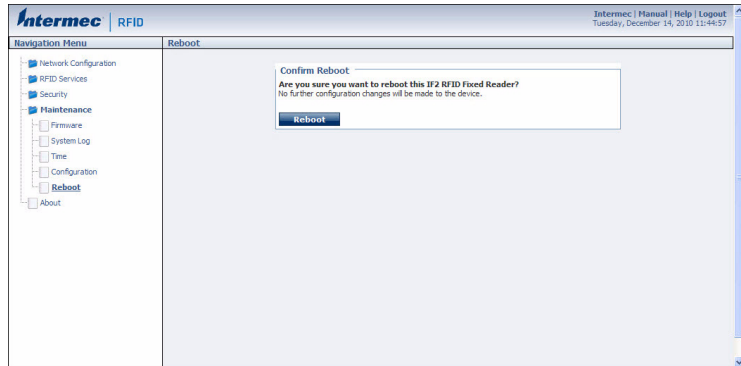

- 2 Click **Reboot** to reboot the IF2. You need to log in again after the IF2 reboots.

Troubleshoot the IF2

This section includes lists of problems and possible solutions.

Problems While Working with RFID

Many problems you may encounter when working with your RFID system can be solved by carefully checking the RFID settings and changing them accordingly. For help, see [“About RFID Services” on page 39](#).

RFID Problems and Solutions

Problem	Solution
The IF2 is unable to read RFID tags, or seems to read tags slowly or inconsistently.	<p>Check these conditions:</p> <ul style="list-style-type: none">• Your RFID antennas must be connected correctly to the IF2 and mounted in optimum locations. Make sure all antenna connections are tight and that the cables are in good condition. For help, contact your Intermec RFID system consultant.• To maximize IF2 performance, make sure you have chosen the correct tag types for your application. For help, see “Configure BRI Settings” on page 40.
The IF2 does not respond to your RFID application.	<p>Your application may not be communicating with the IF2 BRI server.</p> <p>You may need to change BRI server settings to communicate with your application. For example, if your application is running on a desktop PC, you need to enable external BRI connections to the IF2. For help, see “Configure the BRI Server” on page 45.</p>

Connect Directly to the RFID Module

If your application does not appear to be communicating with the IF2 RFID module, you can use a communications program to verify that the RFID module is working properly.

You need to know the IF2 IP address to connect directly to the RFID module. To verify that the RFID reader is reading tags, you need a known good RFID antenna and at least one good RFID tag.

To connect directly to the IF2 RFID module and verify operation

- 1 Make sure the RFID antenna is connected properly to the IF2.
- 2 Apply power to the IF2.
- 3 Use a communications program (such as HyperTerminal) to open a TCP/IP connection to the IF2 with these parameters:

Parameter	Value
IP Address	IP address of the IF2
Port	2189

Configure the communications program to echo typed characters locally and to send line feeds with line ends.

- 4 Press **Enter**. The BRI prompt (OK>) appears.

If the prompt does not appear, there may be a problem with the RFID module or your connection to the module.

- 5 Type **ATTRIB** and press **Enter**. A list of the current settings for the RFID module appears, indicating that the module is receiving commands.

```
FIELDSEP=""
FIELDSTRENGTH=30DB,30DB,30DB,30DB
TIMEOUTMODE=OFF
CHKSUM=OFF
NOTAGRPT=ON
IDREPORT=ON
SESSION=2
INITIALQ=4
INITTRIES=1
IDTRIES=1
ANTTRIES=3
IDTIMEOUT=100
ANTTIMEOUT=50
RDTRIES=3
WRTRIES=3
LOCKTRIES=3
SELTRIES=1
UNSELTRIES=1
RPTTIMEOUT=0
DENSEREADERMODE=OFF
SCHEDULEOPT=0
EPCC162PARAMETERS=11
OK>
```

If the list does not appear, there may be a problem with the RFID module.

- 6 (Optional) To verify that the RFID module is reading tags:
 - a Place a known good RFID tag within range of the antenna.
 - b Type **READ** and press **Enter**. The tag ID appears, indicating that the module is reading tags.

If the tag ID does not appear, there may be a problem with the RFID module or antenna system.

Problems With Connectivity

When troubleshooting problems with connectivity, make sure you know and understand these network-specific items:

- TCP/IP settings
- COM port settings for serial connections

You should also make sure all physical network connectors and cables are in good working order.

Connectivity Problems and Solutions

Problem	Solution
You cannot connect to the IF2 using the serial port.	<ol style="list-style-type: none"> 1 Verify that you are using a null-modem cable to connect to the desktop PC. 2 Verify that you are communicating through the correct serial port. 3 Verify that your PC is set to 115200, N, 8, 1, no flow control.
You cannot connect to the IF2 using a web browser.	<ol style="list-style-type: none"> 1 Verify that you have the correct IP address for the IF2. 2 If you access the Internet through a proxy server, be sure you have added the IP address of the IF2 to the Exceptions list.
You cannot load a security certificate.	You must use a secure web browser connection to load certificates. For help, see “Use the Web Browser Interface” on page 11.
You have assigned a static IP address to the IF2 but cannot connect to the IF2 over your network.	Make sure that DHCP is disabled and that your TCP/IP parameters are set correctly. For help, see “How to Communicate with the IF2” on page 8.

Call Intermec Product Support

You may need to call Product Support if you have problems operating the IF2. Before calling, be sure you can answer the following questions:

- What kind of network are you using?
- What were you doing when the error occurred?
- What error message did you see?
- What is your RFID reader's serial number?
- Can you reproduce the problem?
- What versions of IF2 and RFID software are you using? For help, see **“View the About Screen” on page 69**.

When you have gathered this information, call Intermec Product Support at 1-800-755-5505.

Access Web Pages

Periodically, IF2 firmware updates can be downloaded from www.intermec.com.

You can use the IF2 web browser interface to visit www.intermec.com or to download manuals from Intermec as described next.

To access Intermec web pages

- 1 Open a web browser interface to the IF2. For help, see **“Use the Web Browser Interface” on page 11**.
- 2 To go to www.intermec.com, click **Intermec** in the upper right corner.



To locate IF2 firmware updates, from the main Intermec web page choose **Support > Downloads** and search for IF2.

Or, to download an Intermec product manual, click **Manual** in the upper right corner.



Follow the prompts to search for and download manuals or other documentation.

Upgrade Firmware



Make sure the IF2 is connected to a reliable power source before you upgrade the firmware. Do not cycle power to the IF2 during the upgrade. If power is lost during the upgrade, the IF2 may require factory repair.

This section explains how to configure and install firmware upgrades on the IF2.



Note: To upgrade the firmware, use only .bin files provided by Intermec. Be sure to contact your Intermec RFID system consultant before upgrading. To locate IF2 upgrades, see the previous section, **“Access Web Pages” on page 78.**”

To upgrade the firmware

- 1 Download the Intermec IF2 OS Upgrade Package utility from the Intermec web site. For help, see the previous section, **“Access Web Pages” on page 78.**
- 2 Run the Upgrade Package utility to configure the firmware upgrade file. For help, see the next section.
- 3 Install and run the firmware upgrade file on the IF2. For help, see **“Install the Firmware Upgrade” on page 81.**

Configure the Firmware Upgrade

The Upgrade Package installer configures IF2 firmware upgrades. The configuration you need depends on the method you use to upgrade the IF2:

- Using the web browser interface.
- Using Device Configuration Web Services. For help, see the *Device Configuration Web Services Command Reference Manual*.

This section explains how to choose the correct configuration.

To configure the firmware upgrade file

- 1** Double-click the Upgrade Package utility to run it. The opening screen appears.
- 2** Click **Next**.
- 3** Click **Next** to install the upgrade file at the default location, and then click **Install**. The upgrade file is installed.

To choose a different location:

- a** Click **Browse** to browse to a different location.
 - b** Double-click a folder to choose the location.
 - c** Click **Next**.
 - d** Click **Install**. The file is installed at the new location.
- 4** Click **Finish** to close the utility.

Install the Firmware Upgrade

This section describes the different methods of how to install and run the IF2 firmware upgrade.

Upgrade From the Web Browser Interface

You can use the web browser interface to upgrade the firmware on the IF2.

To upgrade the IF2 using the web browser interface

- 1 From the menu, click **Maintenance > Firmware**. The Firmware screen appears.

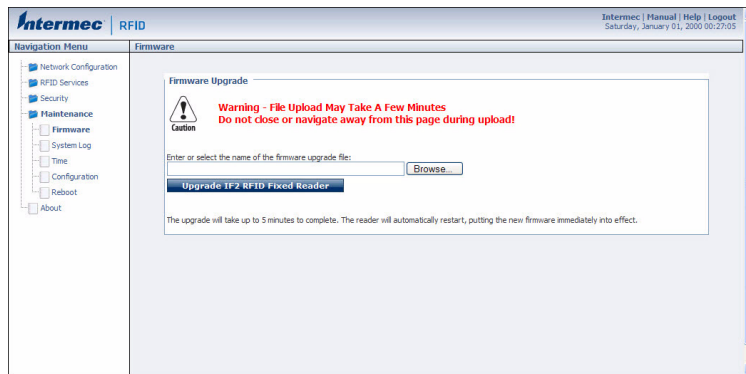

- 2 Click **Browse** to browse to the location of the upgrade file, and then double-click the filename. The name of the file appears in the **Enter or select the name of the firmware upgrade file** entry field.
- 3 Click **Upgrade IF2 RFID Fixed Reader**. The upgrade process begins and the firmware is transferred to the IF2.

During the upgrade, the web browser interface screen does not auto-refresh. Click **Refresh** in the web browser to check the progress of the upgrade. When the login screen appears, the upgrade is complete and the IF2 has already rebooted.



Caution

Do not cycle power to the IF2 during the upgrade. If power is lost during the upgrade, the IF2 may require factory repair.

6

Use the IF2 GPIO Interfaces

This chapter explains how to access the IF2 general purpose input/output (GPIO) interfaces and how to connect industrial controls such as motion sensors or indicator lamps to the IF2. This chapter includes the following topics:

- **About the GPIO Interfaces**
- **Access the Interfaces**
- **Use the Input Interfaces**
- **Use the Output Interfaces**
- **Use the Power Interface**

About the GPIO Interfaces

The IF2 has four general purpose input and output (GPIO) interfaces. You connect external controls such as motion sensors or indicator lamps to the GPIO interfaces, which can then trigger IF2 operations.

Each interface is electrically isolated from the IF2 and designed for low voltage DC loads. The IF2 can also supply 12 VDC at 0.5 A to external devices.

How the inputs and outputs are used depends on the RFID application software being used in the system. You need to coordinate input and output control wiring with the software developer.

If your application uses the IF2 GPIO interfaces to control external devices such as indicator lamps, running the application on the IF2 may decrease response time for those devices. For more information, see [“Install Applications on the IF2 with Expanded Memory Option” on page 51](#).

Access the Interfaces

You can access the GPIO interfaces through the IF2 GPIO port. The port uses a standard 25-pin serial cable. For port pin assignments, see [“Port Pin Assignments” on page 94](#).

Intermec offers these GPIO accessories:

- The GPIO Terminal Block (P/N 203-726-xxx). Use this accessory to connect devices to the IF2 GPIO interfaces. The block provides access to the IF2 GPIO interfaces via standard screw terminals.
- The Light Stack Kit (P/N 203-858-xxx). This 3-color indicator light and beeper connects directly to the IF2 GPIO port and is triggered by the output interfaces. The kit includes a connecting cable.
- The Sensor Kit (P/N 203-859-xxx). This motion sensor connects directly to the IF2 GPIO port and triggers the input interfaces. The kit includes a mounting bracket and connecting cable.
- The Light Stack and Sensor Kit (P/N 203-860-xxx). This kit includes the light stack, a sensor with mounting bracket, and connecting cable.

For more information on these GPIO accessories, contact your local Intermec distributor.

Use the Input Interfaces

Each of the four inputs is compatible with input signals of 10 to 36 VDC. Both the high and low signal contacts are exposed and isolated to 1500 V. Input impedance is 1.8 K ohms minimum.

GPIO Input Signal Descriptions

Signal	Description	Min.	Typical	Max.
V _{in} (High)	High input voltage	10 V	24 V	36 V
V _{in} (Low)	Low input voltage	-1 V	0 V	1 V

In a typical application, the IF2 senses input from an external control like a switch and then starts a tag read operation.

There are three basic ways to connect input controls to the IF2 input interfaces:

- Supply the input interface with power from the IF2.
- Isolate the IF2 from the input power source.
- Use an open collector solid state drive from a remote device to control the inputs.

For more information, see the next examples.

IF2 Powered Input

This is the simplest way to connect a control to an IF2 input interface. If the external control device is a switch, you can connect one side of the switch to an IF2 +Input pin, and the other side of the switch to one of the +12 VDC sources. Ground the corresponding -Input pin as shown in the next illustration.

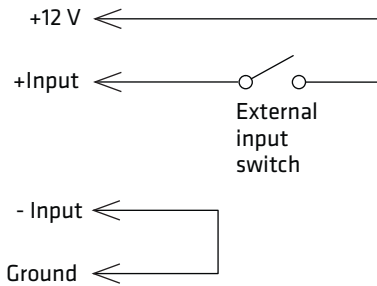

IF2 Powered Input

Isolated Input Interface

Use this method to minimize noise induced by distance or grounding characteristics. The isolated input avoids induced noise by referencing a remote input to chassis return of the IF2. The next illustration shows how this method is wired.

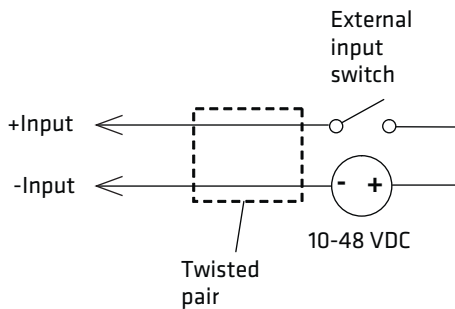

Isolated Input Interface

Open Collector Input Interface

The input can be connected to an open collector interface of an external device. This typically implies that the grounds are tied together for the two systems. The common ground can be a source of input noise, so you should follow good grounding practices for both the IF2 and the input device.

In this situation, the IF2 provides power to the pull-up resistor for the open collector. Connect the +Input pin to the +12 VDC source as shown in the next illustration.

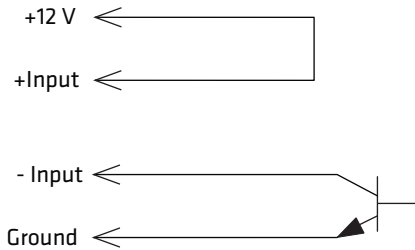
**Open Collector Input Interface**

Use the Output Interfaces

Each IF2 output interface is optically isolated from the IF2, polarized, and rated for 5 to 48 VDC at 0.25 A. All IF2 outputs include internal thermal fuses that trip if the load exceeds 0.25 A, and the fuses are self-recovering once the excessive load is removed. The high and low contacts are exposed and isolated from ground. Transient suppression limits output voltage spikes to 65 VDC.

GPIO Output Specifications

Signal	Description	Min.	Typical	Max.
Leakage current (High)	Switch output, high leakage current	0 mA	1 mA	10 mA
V_{sat} (Low)	Switch output on, saturation voltage with 0.25A load	0V	1V	1.5V

Because the outputs are optically isolated, each one can be configured to switch the high side or the low side of the load. You can power the load directly from the IF2 or from an external power supply.

In a typical application, the outputs control indicator lamps that signal good reads or errors. The basic methods for connecting external devices to the GPIO outputs include:

- Switching the high side, with the load powered by the IF2
- Switching the low side, with the load powered by the IF2
- Switching the high side, with the load powered externally
- Driving a DC relay that controls an AC load

These methods are shown in the next examples.

Switch the High Side With IF2 Power

In this example, an external indicator lamp (0.25 A maximum current) is connected to the -Output and Ground pins, and the corresponding +Output pin is connected to the +12 VDC source.

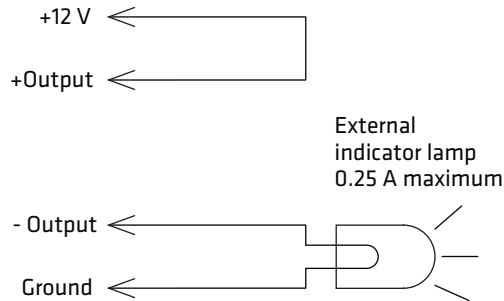

Switching the High Side

Switch the Low Side With IF2 Power

For low side switching applications, the lamp power is routed to all the lamps in common and the low side of the load is routed to the switch.

In this method, connect the external indicator lamp to the +Output and +12 VDC pins, and short the corresponding -Output pin to ground as shown.

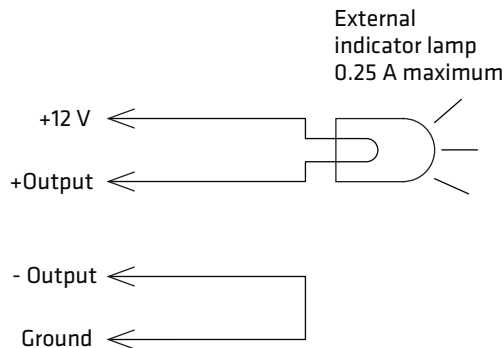

Switching the Low Side of the Output Load

Switching the High Side With External Power

To use external power (5 to 48 VDC) to switch the high side, connect the Ground pin to the ground system of the external power supply, and connect the positive side of the external supply to the +Output pin. The external indicator lamp is connected to the corresponding -Output and Ground pins as shown in the next illustration.

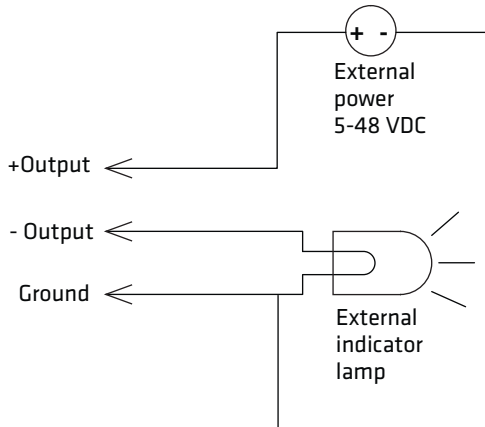

Switching the High Side With External Power

Drive a DC Relay to Control an AC Load

While the IF2 outputs are designed to switch DC loads, they can drive relays that control AC loads. The next illustration shows how to connect such a system to an IF2 output.

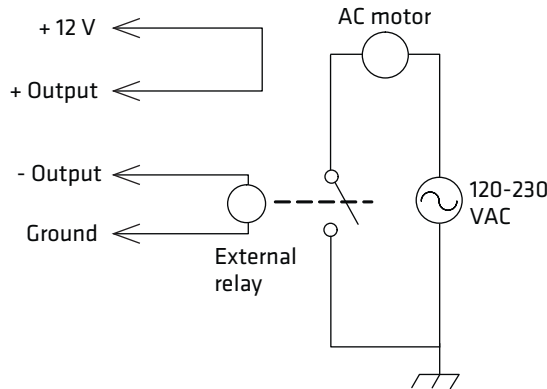

Driving a DC Relay: The external relay provides dry contacts for controlling the AC motor.



Note: In many installations, the relay and AC wiring must be placed in an enclosure that meets local fire code regulations.

Use the Power Interface

The IF2 GPIO interface provides 12 VDC at 0.5 A for powering external inputs and loads, eliminating the need for an external DC supply and simplifying the system installation.

The GPIO interface power has an internal thermal fuse that trips if the load exceeds 0.5 A. The fuse is self-recovering once the excessive load is removed.

The total load on the GPIO interface power must stay within the 0.5 A limit. When you design a system that uses the GPIO interface power, be sure to complete a power budget assessment to ensure that the supply is adequate for the system.

If your system needs more than +12 VDC at 0.5 A, you can connect an external power supply to the +12 V and Ground pins. The external supply powers the external loads, and that power will be available at all +12 V pins on the GPIO port.

A

Specifications

This appendix includes physical and electrical specifications for the IF2 and information about the port pin assignments.

IF2 Specifications

Specifications	Values
Height	19.9 cm (7.87 in)
Length	18.8 cm (7.42 in)
Width	4.3 cm (1.7 in)
Weight	1 kg (2.2 lb)
DC electrical rating	12 V +/- 5%, 30 W (55 V, 30 W for High Power Over Ethernet)
Operating temperature	-20 °C to +55 °C (-4°F to +131 °F)
Storage temperature	-30 °C to +70 °C (-22 °F to +158 °F)
Humidity (non-condensing)	5% to 95% non-condensing
Ethernet interfaces	10BaseT/100BaseTx (twisted-pair) with 802.3 at High Power Over Ethernet (POE)
Ethernet compatibility	Ethernet frame types and Ethernet addressing
Ethernet data rate	10 Mbps/100 Mbps
Serial port maximum data rate	115,200 bps
IF2 with Expanded Memory Option	96 MB of flash application memory 96 MB of flash data storage 64 MB RAM

RFID Specifications

Specifications	Values
Protocols Supported	EPCglobal Class 1 Gen 2 ISO 18000-6B Generation 1 ISO 18000-6B Generation 2 ATA
Frequency Range	865.6 - 867.6 MHz, or 902 - 928 MHz
Output power 865-867 MHz, 900 MHz	Minimum: 1 dBm Maximum: 30.0 dBm
Occupied frequency bandwidth	<250 KHz
Tag data rate	32 kbps/320 kbps
Dispatch rates	> 200 tags per second
Transmitter type	90% amplitude modulation index
Frequency stability	<±100 ppm from -25 °C to +55 °C (-13 °F to 131 °F)
Number of antennas	Up to 4, electronically switched
Antenna port isolation	22 dB
Antenna connectors	Reverse TNC

Port Pin Assignments

GPIO Port

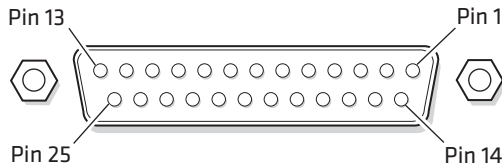

GPIO Port Pin Assignments

Pin	Description	Active Polarity
1	-Input 1	Low-RTN
2	-Input 2	Low-RTN
3	-Input 3	Low-RTN
4	-Input 4	Low-RTN
5	Ground	
6	Ground	
7	+Output 1	High (10-48 V)
8	Ground	
9	+Output 2	High (10-48 V)
10	Ground	
11	+Output 3	High (10-48 V)
12	Ground	
13	+Output 4	High (10-48 V)
14	+Input 1	High (10-48 V)
15	+Input 2	High (10-48 V)
16	+Input 3	High (10-48 V)
17	+Input 4	High (10-48 V)
18	12VDC	
19	-Output 1	Low-RTN
20	12VDC	
21	-Output 2	Low-RTN
22	12VDC	
23	-Output 3	Low-RTN

GPIO Port Pin Assignments (continued)

Pin	Description	Active Polarity
24	12 VDC	
25	-Output 4	Low-RTN

Serial Ports (COM1)

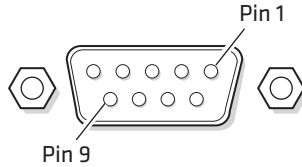

Serial Port Pin Assignments

Pin	Description	Active Polarity
1	NC	
2	Receive data (RXD)	
3	Transmit data (TXD)	
4	NC	
5	Signal ground	
6	NC	
7	Request to send (RTS)	Low
8	Clear to send (CTS)	Low
9	NC	

Ethernet Port

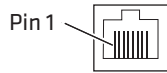

Ethernet Port Pin Assignments

Pin	Description
1	Ethernet TX+/Spare POE return
2	Ethernet TX-/Spare POE return
3	Ethernet RX+/Spare POE 48 VDC
4	Not used/POE 48 VDC
5	Not used/POE 48 VDC
6	Ethernet RX-/Spare POE 48 VDC
7	Not used/POE return
8	Not used/POE return



Index

Symbols

.NET programming
 support, described 53
 \$JAVA_HOME, described 54

A

About screen 69
 AC power port
 location 5
 Antenna Tries setting 44
 ANTTRIES equivalent 44
 applications
 .NET support 53
 auto-starting at boot time 56
 configuring BRI server 45
 installing on IF61 55
 Java support 53
 Java, executing on IF61 54
 using with IF2 38
 Auto-Start check box, for
 applications 56
 auto-starting applications at boot
 time 52, 56

B

Basic Reader Interface
 attribute equivalents for BRI
 Attribute settings 41
 attributes, changing 40
 BRI Commands screen, in
 Developer Tools 59
 described 40
 external connections, enabling
 46
 script files, loading and running
 with Developer Tools 59
 sending commands with
 Developer Tools 58
 TCP Port setting, for BRI server
 46
 blue LED, described 5
 Bonjour service advertisement,
 enabling 28
 BRI Commands screen 59
 BRI server
 BRI TCP Port 46
 configuring 45
 Enable External BRI
 Connections 46
 Enable Logging 46
 log, enabling and viewing 46

logfile command event
 descriptions 47
 settings, described 46
 using with Intermecc Ready-To-
 Work indicator 5

BRI TCP Port setting, for BRI server
 46

BRI. *See* Basic Reader Interface

C

cable access door, removing 5
 CDC/Foundation profile 53
 Certificate Details screen,
 illustrated 34
 certificates
 described 33
 installing and uninstalling 35
 viewing 34
 Common Internet File System
 shares, enabling 25
 configuring the IF2
 BRI server 45
 connecting with
 communications program
 8
 default configuration, restoring
 70
 DHCP settings 24
 DNS settings 25
 Ethernet link speed 9
 Ethernet settings 22
 firmware, upgrading 79
 network settings 22, 25
 password server 29
 RFID services 39
 RFID settings 40
 saving changes 13
 security 26
 serial port connection 64
 setting IP address, described 8
 SNTP settings 25
 SYSLOG destination 25
 user name and password, setting
 28
 using web browser interface 11
 viewing software versions 69
 web service 62
 connecting IF2 to network 16

D

date and time

- setting with web browser interface 18
 - SNTP client settings 25
- default configuration, restoring 70
- default login, changing 31
- defaults, restoring 70
- Dense Reader Mode, enabling 44
- DENSEREADERMODEequivalent 44
- Developer Tools 58
 - BRI Commands 59
 - enabling 56
 - GPIO, testing 58
 - JavaScript files, working with 59
 - Workbench 59
- developing applications
 - .NET support 53
 - access services, controlling 27
 - Java support 53
 - Mono support 53
 - testing with Developer Tools 58
 - using with IF2 38
 - with Intermecc RFID Resource Kit 39
- Device Configuration web service 62
- DHCP settings, configuring 24
- diagnostics
 - BRI server event log, viewing 46
 - events log, viewing 68
- DNS
 - server IP address, setting 26
 - settings, configuring 25
 - suffixes, setting 26
- DRM equivalent 44
- E**
- edgware
 - auto-starting at boot time 56
 - Developer Tools, described 57
 - enabling in web browser interface 56
 - updates, locating 78
- electrical specifications 92
- Enable DHCP check box
 - Ethernet 24
- Enable External BRI Connections
 - setting 46
- Enable Help check box 14
- Enable Logging check box, for BRI server 46
- Enable RADIUS check box 30
- Enable Serial Configuration check box 32, 33
- Enable Web Server check box 28
- environmental requirements 16
- EPCC1G2 Access mode, enabling 44
- EPCC1G2PARAMETERS
 - equivalent 44
- EPCC1G2PARMS equivalent 44
- EPCglobal Class 1 Gen 2
 - tags, choosing in BRI Attribute settings 41
- Ethernet
 - IF2 in wired network, illustrated 3
 - link speed, configuring 9
 - port
 - described 6
 - location 5
 - pin assignments 96
 - settings, configuring with web browser interface 22
 - troubleshooting problems 77
- events log, viewing in Maintenance menu 68
- external controls, using with IF2 84
- F**
- Field Separator setting 42
- Field Strength setting 45
- fields, in tags, separating 42
- FIELDSEP equivalent 42
- FIELDSTRENGTH equivalent 45
- firmware, upgrading 79
 - installing upgrade file on IF2 81
 - overview 79
 - upgrade file, configuring 80
 - web browser interface 81
- Forced Client Termination 49
- front panel ports
 - accessing 5
 - described 6
- G**
- general purpose input/output
 - interfaces
 - accessing 84
 - described 84
 - Developer Tools, testing with 58
 - inputs, using 85
 - isolated input 86

- open collector input 86
 - output, switching high side
 - using external power 89
 - output, switching the high side 88
 - output, switching the low side 88
 - outputs, using 87
 - port location 5
 - port pin assignments 94
 - power, using 90
 - powered input 85
 - relay, driving to control AC load 89
- GPIO. *See* general purpose input/output interfaces
- H**
- Help screen, illustrated 13
 - help text, in web browser interface 13
 - hostname 26
 - http
 - //support.ntp.org 25
 - HyperTerminal, using to configure IF2 8
- I**
- ID Report check box 42
 - ID Tries setting 44
 - IDREPORT equivalent 42
 - IDTRIES equivalent 44
 - IF2
 - connecting to network 16
 - connecting with communications program 8
 - default configuration, restoring 70
 - described 2
 - developer access, controlling 27
 - dimensions 92
 - environmental requirements, listed 16
 - Ethernet network, described and illustrated 3
 - firmware, upgrading 79
 - installing 15
 - locating with LEDs 70
 - maintaining 68
 - managing 62
 - mounting location, choosing 15
 - overview 2
 - rebooting via web browser interface 73
 - related documents, list of xiii
 - RFID settings, configuring 39
 - specifications 92
 - troubleshooting 74
 - using securely 19
 - IF61
 - .NET support 53
 - Java support 53
 - POE, connecting 4
 - indicator lamps, external
 - testing with IF61 58
 - using with IF2 84
 - Initial Q setting 43
 - Initialization Tries setting 43
 - initialize tags setting 43
 - INITIALQ equivalent 43
 - INITTRIES equivalent 43
 - input interface
 - isolated 86
 - open collector 86
 - powered 85
 - signal descriptions 85
 - Install User Application screen 55
 - installing
 - edgware 57
 - IF2 15
 - RFID antennas 16
 - Intermec
 - manuals, how to download from web xiii, 78
 - Product Support, what to know when calling 78
 - IP address
 - Ethernet 24
 - setting with communications program 8
 - setting with web browser interface 22
 - IPv6 settings
 - Ethernet 24
 - ISO6B tags, choosing 41
- J**
- J2SE support 53
 - Java programming
 - \$JAVA_HOME 54
 - IF61 support 53
 - jar files, running 54

- JIT compiler, enabling 54
- JVM name 54
- libraries, described 53
- running applications on IF61 54
- Java runtime executable on IF61, described 54
- JavaScript
 - files, testing with Workbench 59

L

- LEDs
 - described 3
 - Intermec Ready-To-Work Indicator 3
 - location 3
 - power 3
 - RFID Transmit 4
 - Tag ID 4
 - using to locate the IF2 70
 - wired LAN 3
- Link Local IP Address 24
- LLRP. *See* Low-Level Reader Protocol
- location, choosing for IF2 15
- Lock Tries setting 41
- LOCKTRIES equivalent 41
- login screen 11
- login, changing default 31
- Low-Level Reader Protocol 48
 - configuring settings 48
 - settings, described 49

M

- maintaining the IF2 68
- Maintenance menu 68
 - events log, viewing 68
 - locating the IF2 70
 - using LEDs to locate the IF2 70
- managing the IF2
 - defaults, restoring 70
 - developer access, controlling 27
 - Device Configuration web service 62
 - firmware, upgrading 79
 - methods 62
 - security, configuring 26
 - using securely 19
- manuals, Intermec, how to
 - download from web *xiii*, 78
- Mono, support for .NET applications 53
- motion sensors, external

- testing with IF61 58
- using with IF2 84
- mounting location, choosing 15

N

- network
 - configuring settings 22
 - connecting IF2 to 16
 - IF2 illustrated in 2
- NFS volumes, enabling 25
- No Tag Report check box 42
- NOTAGRPT equivalent 42
- NOTAGS message, enabling or disabling 42

O

- OSGi support 54
- output interface
 - driving external DC relay 89
 - high side switching 88
 - high side switching with external power 89
 - low side switching 88
 - signal descriptions 87
- overview of the IF2 2

P

- password settings, described 31
- Password, setting on IF2 32
- Phillips 1.19 tags, choosing 41
- pin assignments, for ports 94
- POE LED 4
- port pin assignments
 - Ethernet 96
 - GPIO 94
 - serial 95
- ports
 - Ethernet 6
 - front panel, accessing 5
 - front panel, described 6
 - GPIO 6
 - pin assignments 94
 - serial 6
 - top panel, described 7
- power interface 90
- Power LED 4
- Power Over Ethernet 4
- problems with IF2, solving 74
- Product Support, calling Intermec 78
- proxy server, using to access Internet 11

- R**
- RADIUS
 - authentication server, described 28
 - enabling 30
 - settings, described 30
 - RDTRIES equivalent 41
 - Read Tries setting 41
 - reader module, changing settings 40
 - reader-initiated connections, configuring for LLRP 49
 - Read-only Password setting 32
 - Ready-to-Work indicator, described 5
 - rebooting the IF2 73
 - Report Timeout setting 42
 - RFID
 - antenna port locations 7
 - applications, using with IF2 38
 - connecting directly to reader module 75
 - Developer Tools 58
 - edgware, enabling 56
 - IF2 settings, described 41
 - Java support 53
 - module, configuring 39
 - Resource Kit, described 39
 - specifications 93
 - troubleshooting problems 74
 - RFID Transmit LED 4
 - Router entry field
 - Ethernet 24
 - running Java applications on IF61 54
- S**
- SAP device controller edgware, described 57
 - Schedule Option setting 44
 - SCHEDULEOPT equivalent 44
 - Secure Server Enable check box 49
 - secure web browser interface, using 11
 - securely using the IF2 19
 - security
 - access services, controlling 27
 - certificates, described 33
 - configuring 26
 - default login, changing 31
 - password server, using with IF2 29
 - supported methods 26
 - Select Tries setting 43
 - SELTRIES equivalent 43
 - serial connection to IF2 64
 - serial port
 - access, enabling for configuration 32
 - connecting to IF2 64
 - location 5
 - pin assignments 95
 - restoring defaults via serial connection 72
 - SESSION equivalent 43
 - Session setting 43
 - Simple Network Time Protocol (SNTP) client settings, configuring 25
 - SNTP client settings, configuring 25
 - specifications
 - electrical and physical 92
 - RFID 93
 - Start button, for applications 56
 - Stop button, for applications 56
 - Subnet Mask entry field
 - Ethernet 24
 - support, calling Intermecc 78
 - SYSLOG destination
 - configuring 25
 - defined 26
 - SYSLOG server 26
- T**
- Tag ID LED 4
 - Tag Types setting 41
 - tags, RFID
 - choosing Gen 2 type 41
 - choosing ISO type 41
 - ID reporting, enabling or disabling 42
 - TAGTYPE equivalent 41
 - TCP/IP settings, configuring 22
 - time and date
 - setting with web browser interface 18
 - SNTP client settings 25
 - Time screen 18
 - Timeout Configuration mode, enabling 42

- TIMEOUTMODE equivalent 42
- top panel ports, described and illustrated 7
- troubleshooting the IF2 74
 - connecting directly to RFID reader module 75
 - connectivity problems 77
 - default configuration, restoring 70
 - Intermec Product Support, calling 78
 - Maintenance menu, viewing 68
 - RFID problems 74
 - turning off help text 13
- U**
- Uninstall button, for applications 56
- Universal Plug and Play
 - advertisement, enabling 28
 - service 27
- Unsecure Server Enable check box 49
- Unselect Tries setting 43
- upgrade files, where to find 79
- Upgrade Package utility 80
- upgrading firmware 79
- Username setting, for passwords 31
- W**
- web browser interface 11
 - BRI server, changing settings 45
 - date and time, setting 18
 - Developer Tools 58
 - DNS settings 25
 - enabling 28
 - help text, disabling 13
 - IF2 default settings, restoring 70
 - IP address, setting 22
 - login screen 11
 - Maintenance menu 68
 - reader settings 40
 - RFID edgware, enabling 56
 - secure 11
 - secure only, enabling 28
 - SNTP settings 25
 - SYSLOG destination 25
- web service, configuring with 62
- Wired LAN LED 4
- Write Tries setting 41
- WRTRIES equivalent 41
- WSDL document, downloading 63
- www.intermec.com, accessing from
 - IF2 web browser interface 78



by Honeywell

6001 36th Avenue West
Everett, Washington 98203
U.S.A.

tel 425.348.2600

fax 425.355.9551

www.intermec.com

© 2014 Intermec by Honeywell
All rights reserved.



IF2 Network Reader User's Manual



P/N 935-040-002